



Barratt David Wilson Homes (Mercia)

Hither Green Lane, Redditch

Transport Assessment

October 2021

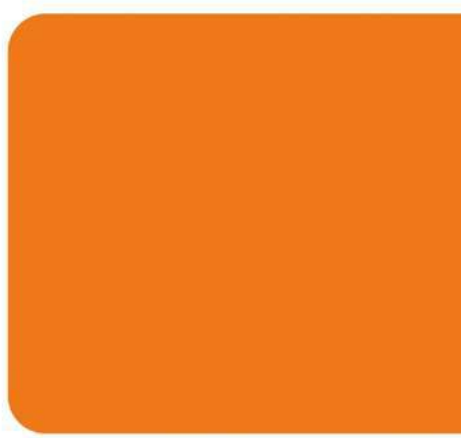

Barratt David Wilson Homes (Mercia)

Hither Green Lane, Redditch

Transport Assessment

OFFICE ADDRESS:

Lombard House,
145 Great Charles Street,
Birmingham,
B3 3LP

PROJECT NO:

325756

DATE:

October 2021

REPORT No:	FILE NAME	PREPARED:	DATE OF ISSUE:	STATUS:	CHECKED:	AUTHORISED:
001	211015_325756_T A 001.docx	MS / JN	15 October 2021	Final	JB	AS

CHANGE LOG

VERSION	DATE:	CHECKED BY:	REASON FOR CHANGE:
---------	-------	-------------	--------------------

CONTENTS

1.	Introduction	4
1.1	Overview	4
1.2	Development Proposals	4
1.3	Report Structure	4
2.	Policy Review	6
2.1	Introduction	6
2.2	National Policy	6
2.3	Local Policy	9
2.4	Summary	14
3.	Existing Conditions	15
3.1	Overview	15
3.2	Site Context	15
3.3	Local Highway Network	16
3.4	Planning Context	17
3.5	Existing Baseline Traffic Flows	19
3.6	Highway Safety	19
3.7	Sustainable Access	21
3.8	Public Transport	26
3.9	Proximity to Local Services and Facilities	28
3.10	Existing Modal Journey Share	29
3.11	Summary	30
4.	Development Proposals	31
4.1	Overview	31
4.2	Vehicular Access	31
4.3	Emergency Access	31
4.4	NMU Access	32
4.5	Public Transport	33
4.6	Parking	34
5.	Forecast Traffic Generation and Distribution	35
5.1	Overview	35

© Copyright mode transport planning. All rights reserved

This report has been prepared for the exclusive use of the commissioning party and unless otherwise agreed in writing with mode transport planning, no other party may copy, reproduce, distribute, make use of, or rely on the contents of the report. No liability is accepted by mode transport planning for any use of this report, other than for the purposes for which it was originally prepared and provided.

Opinions and information provided in this report are on the basis of mode transport planning using due skill, care and diligence in the preparation of the same and no explicit warranty is provided as to their accuracy. It should be noted and is expressly stated that no independent verification of any of the documents or information supplied to mode transport planning has been made.

5.2	Trip Rates	35
5.3	Trip Generation	36
5.4	Traffic Distribution	37
6.	Junction Analysis	39
6.1	Introduction	39
6.2	Traffic Flows	39
6.3	Assessment Scenarios	40
6.4	Development Impact at Junctions – Screening	40
6.5	Junction Capacity Analysis	43
7.	Summary & Conclusion	50
7.1	Summary	50
7.2	Conclusion	52

APPENDICES

APPENDIX A	Illustrative Masterplan
APPENDIX B	Committed Highways Mitigation Scheme
APPENDIX C	Collision Data
APPENDIX D	Highway Drawings
APPENDIX E	TRICS Search Outputs
APPENDIX F	Traffic Flow Diagrams
APPENDIX G	Junction Capacity Assessment Outputs
APPENDIX H	Dagnell End Mitigation – Stage Sequence Figures

1. Introduction

1.1 Overview

1.1.1 mode transport planning (mode) has been appointed by Barratt David Wilson Homes (Mercia) to provide highways and transport advice in relation to the submission of an outline planning application for land adjacent to Hither Green Lane in Redditch, Worcestershire. The proposed masterplan is attached at **Appendix A**.

1.2 Development Proposals

1.2.1 The proposals involve the development of 216 residential dwellings on the site; which comprises the north-western parcel of the existing golf course located to the west of Hither Green Lane. The site is bound by Dagnell End Road to the north, Hither Green Lane to the east, the River Arrow to the south and Meadow Farm Public House to the west.

1.2.2 This Transport Assessment (TA) considers the transport issues at the site and identifies the likely impacts of the proposed development with all modes of travel considered. It sets out the methodology for assessing the baseline conditions and proposed development schedule and provides a summary of the various associated transport implications.

1.2.3 A Residential Travel Plan (RTP) has also been prepared and should be read in conjunction with this TA. The RTP sets out incentives to assist in reducing the number of vehicle-based trips associated with the development, and increase the number of pedestrian, cycle and public transport trips.

1.3 Report Structure

1.3.1 This Transport Statement has been prepared in accordance with Planning Practice Guidance (PPG) 'Travel Plans, Transport Assessment and Statements in Decision-Taking' published by the Ministry of Housing Communities and Local Government (MHCLG) in 2014 and Worcester County Council's (WCC) Local Transport Plan (2018), and is structured as follows:

- **Chapter 2** – provides an overview of relevant national and local planning policies;
- **Chapter 3** – reviews the existing transport infrastructure in the area surrounding the site, with a focus on opportunities for travel via sustainable modes;
- **Chapter 4** – outlines the development proposals and access arrangements;

- **Chapter 5** – provides an overview of the trip generation associated with the proposed development, in addition to details regarding the distribution of traffic and subsequent assignment of trips onto the local highway network;
- **Chapter 6** – reviews the potential impact on the local highway network; and,
- **Chapter 7** – summarises and concludes the TA.

2. Policy Review

2.1 Introduction

2.1.1 This chapter introduces the statutory transport policy and best practice guidance relevant to the proposed development, which is found within the following documents:

- National Planning Policy Framework (NPPF) – 2021;
- Planning Practice Guidance (PPG) – 2018;
- Borough of Redditch Local Plan (BRLP) – 2017; and,
- Worcestershire Local Transport Plan 4 (LTP4) (2018).

2.2 National Policy

National Planning Policy Framework (NPPF)

2.2.1 The National Planning Policy Framework (NPPF) sets out the Government's key objectives for achieving sustainable development. The NPPF was published in March 2012 and revised in February 2019. This document was again revised in July 2021 and replaces the previous version in order to streamline the national planning policies set out in previous policy guidance and a number of related circulars. These have been combined into a single document to make the planning system more accessible, whilst still protecting the environment and promoting sustainable growth.

2.2.2 The NPPF sets out the government's planning policies for England, and how these are expected to be applied, stating that all developments generating significant amounts of movement should be supported by a TA or Transport Statement (TS), alongside a Travel Plan (TP). Within the NPPF, it is suggested that an economic, social and environmental objective should be at the heart of the planning process.

2.2.3 Under the 'Promoting sustainable transport' chapter of the NPPF, it is stated that transport issues should be considered from the earliest stages of plan-making and development proposals (Para. 104). By doing this the potential impacts of development on transport networks can be addressed and the appropriate transport infrastructure can be implemented. By considering transport at the earliest stages, it allows the opportunity to promote walking, cycling and public transport, and mitigate any problems.

2.2.4 Significant developments should be focused on being sustainable, this can be done through limiting the need to travel and offering a genuine choice of transport modes.

2.2.5 The NPPF states (Para. 106, pg.30) that planning policies should:

- “Support an appropriate mix of uses across an area, and within larger scale sites, to minimise the number and length of journeys needed for employment, shopping, leisure, education and other activities;
- Be prepared with the active involvement of local highways authorities, other transport infrastructure providers and operators and neighbouring councils, so that strategies and investments for supporting sustainable transport and development patterns are aligned;
- Provide for attractive and well-designed walking and cycling networks with supporting facilities such as secure cycle parking, Local Cycling and Walking Infrastructure Plans.”

2.2.6 Within the context of assessing sites for that may be allocated for development in plans, or specific applications for development, it should be ensured that (Para. 110, pg.31):

- “Appropriate opportunities to promote sustainable transport modes can be – or have been – taken up, given the type of development and its location;
- safe and suitable access to the site can be achieved for all users;
- the design of streets, parking areas, other transport elements and the content of associated standards reflects current national guidance, including the National Design Guide and the National Model Design Code; and
- any significant impacts from the development on the transport network (in terms of capacity and congestion), or on highway safety, can be cost effectively mitigated to an acceptable degree.”

2.2.7 Within this context, new developments should (Para. 112, pg.32):

- “give priority first to pedestrian and cycle movements, both within the scheme and with neighbouring areas... facilitating access to high quality public transport, with layouts that maximise the catchment area for bus or other public transport services, and appropriate facilities that encourage public transport use.
- address the needs of people with disabilities and reduced mobility in relation to all modes of transport;
- create places that are safe, secure and attractive – which minimise the scope for conflicts between pedestrians, cyclists and vehicles, avoid unnecessary street clutter, and respond to local character and design standards;
- allow for the efficient delivery of goods, and access by service and emergency vehicles; and
- be designed to enable charging of plug-in and other ultra-low emission vehicles in safe, accessible and convenient locations.”

2.2.8 Paragraph 111 states that:

“Development should only be prevented or refused on highways grounds if there would be an unacceptable impact on highway safety, or the residual cumulative impacts on the road network would be severe.”

2.2.9 Paragraph 113 concludes that all developments expected to generate significant amounts of movement should provide a TP, and applications should also be supported by a TS or TA to assess the likely impacts of the proposals.

2.2.10 The sustainable credentials and accessibility of the site are presented in Chapters 3 and 4 of this report, where it is demonstrated that the site is accessible and accords with relevant national policy. Chapters 5, 6 and 7 demonstrate that the traffic associated with the proposed development would not have a severe and/or detrimental impact on the local highway network.

Planning Practice Guidance (PPG)

2.2.11 Planning Practice Guidance (PPG) provides detailed advice to support the NPPF. PPG contains further information for planners, developers and the public on the types of assessment required to support planning applications and the approach to considering applications on their various merits.

2.2.12 The NPPG was published in 2012 and most recently revised in 2018. The updated guidance aims to facilitate the development of a robust and well thought out site, enabling an assessment of the transport impacts of both existing and proposed developments. The guidance can inform sustainable approaches to transport. A strong assessment will establish evidence that may be useful in:

- Improving the sustainability of transport provision;
- Enhancing the levels of accessibility;
- Creating a choice amongst different modes of transport;
- Improving health and well-being;
- Supporting economic vitality;
- Improving public understanding of the transport implications of development;
- Enabling other highway and transport authority's/service providers to support and deliver the transport infrastructure that conforms to the Local Plan; and
- Supporting local businesses and the regional economy.

2.2.13 The sustainable credentials and accessibility of the site are presented in Chapter 3 of this report. Further details in respect of the opportunities to promote sustainable travel to and from the site are set out in the RTP which accompanies the application.

2.3 Local Policy

Borough of Redditch Local Plan (BRLP)

2.3.1 The BRLP sets out local planning policies and development principles for the Borough of Redditch. The document is a material consideration in determining planning application and seeks to respond to the issues and challenges in the local area.

2.3.2 The BRLP sets out a vision for the future of places that responds to local challenges. It is envisaged that by 2030: ““Redditch will be successful and vibrant with communities that have access to good job opportunities, good education, good health and are communities that people will be proud to live and work in.” The Vision has also been formulated based on the aspirations of the Redditch community and sets out how Redditch Borough wants to be by 2030.

2.3.3 The BRLP is underpinned by seven key themes which seeks to address local challenges and aspirations:

1. Sustainable places to live which meet our needs:

- Population projections indicate significant new demand for housing over the Plan period due to natural growth and migration.
- Land availability is scarce, particularly Previously Developed Land.
- Cooperate with our neighbours to locate a significant amount of Redditch’s unmet requirements in adjoining Districts.

2. Creating and sustaining a green environment:

- Redditch is located within a highly sensitive landscape with the town’s growth now nearing its natural limits.
- Redditch has a lot of distinctive green features which define Redditch as unique such as open spaces and Green Infrastructure network which needs to be protected.
- Locating growth in places to limit out-commuting, make best use of existing highway infrastructure and promote sustainable transport options.

3. Creating a Borough where businesses can thrive:

- Dealing with high rates of vacancy and B1 office units not fit for purpose.
- Need to focus on catering for internal employer demand for business types.

4. Improving the vitality and viability of Redditch Town Centre and District Centres:
 - There are areas in Redditch Town Centre that are in decline and need regeneration.
 - Some District Centres suffer from safety, safety perception issues and other issues relating to the poor quality of the physical environment.
5. Protecting and enhancing Redditch's historic environment:
 - Redditch has a rich needle-making heritage and historic buildings of local importance to protect.
6. Creating safe and attractive places to live and work:
 - Some areas of Redditch suffer from a poor perception of crime and anti-social behaviour. The implementation of improved design or designing out crime can help reverse this perception.
7. Promoting Redditch's community well-being:
 - Health of Redditch residents needs to be improved.

2.3.4 On account of its origins as a former New Town, Redditch has historically been designed with a focus on private car use, which needs to be addressed with a shift towards public transport and active travel. Policy 19 – Sustainable Travel and Accessibility of the BRLP seeks to contribute towards reducing the causes and impacts of climate change and to encourage safer, sustainable travel patterns, improve accessibility and reduce the need to travel.

2.3.5 Policy 19 states that: "Transport will be coordinated to improve accessibility and mobility, so that sustainable means of travel, reducing the need to travel by car and increasing public transport use, cycling and walking are maximised. This will be achieved by:

- i. meeting development requirements in accessible locations and taking account of interactions between uses. This includes maximising accessibility to, from and between public transport modes and interchanges (bus and rail), maximising accessibility to and from the development sites and increasing access to and from Redditch Railway Station for users, particularly where access points into the Borough create a gateway;
- ii. delivering a comprehensive network of routes for pedestrians and cyclists that is coherent, direct, safe, accessible and comfortable to use. Building on, adapting and extending the pedestrian and cycle network that exists, in particular following 'desire lines' of the pedestrian and ensuring that all members of the community can comfortably move around the Borough;

- iii. ensuring that infrastructure for pedestrians and cyclists that is well designed and safe is prioritised in residential areas and the Town Centre and facilitates walking, cycling and public transport use. Proposals should incorporate appropriate, safe, convenient, well over-looked and well maintained pedestrian and cycle access as an integral feature of the proposed design. Where appropriate new development should prioritise cycleways which run adjacent to footpaths. The provision of improvement of off-cycle routes, footpath links and related infrastructure will be sought in appropriate locations. The Green Infrastructure Network should also be fully integrated into the pedestrian network and cycleways;
- iv. developing the network of cycle routes particularly the National Cycle Network route (wherever an opportunity exists). Cycleways will be sought that are appropriate to the location;
- v. effectively managing the Primary Route Network (PRN) and prevent new accesses onto the network;
- vi. ensuring that public transport infrastructure, services and information is provided for users and operators in order to encourage the use of public transport;
- vii. supporting the provision of coach parking where appropriate; and,
- viii. providing measures which reduce the impact of the environmental problems (including potential Air Quality Management Areas) associated with transport growth and bring forward environmental improvements particularly along major transport routes.”

2.3.6 Policy 20 of the BRLP sets out the Transport Requirements for New Development and states that: “in order to deliver the transport aspirations set out in Policy 19 Sustainable Travel and Accessibility, proposals for development are required to achieve the following standards and are required to submit the following information:

- i. a Transport Assessment will be required where it is considered that development will have significant transport implications. The assessment of traffic impact should be undertaken in line with the policies in the Plan and other relevant transport policy and guidance;
- ii. a Travel Plan will be required alongside all developments which generate significant amounts of movement;

- iii. all proposals should incorporate safe and convenient access arrangements in their design for all potential users (including pedestrians, cyclists, emergency services and waste collection vehicles). Access arrangements should be designed to reflect the function and character of development and its wider surroundings;
- iv. all proposals should discourage unintended through traffic (“rat runs”) within the development site and / or between sites;
- v. all proposals will be expected to be located accessible to local services (in accordance with the retail hierarchy this should either be a parade of local shops of a District Centre) and a public transport link (i.e. bus stop or train station);
- vi. proposals should include parking standards as prescribed by Worcestershire County Council Local Transport Plan No. 3 Highways Design Guide;
- vii. the cumulative effects of development on transport infrastructure must be assessed and solutions sought in line with the policies in this Plan and other relevant transport policy and guidance, with particular regard to the cumulative effects of the delivery of the Strategic Sites;
- viii. ensure that development does not have a detrimental effect on land safeguarded for road development and / or improvement schemes as depicted on the Policies Map;
- ix. ensure that development does not have a detrimental effect on land safeguarded for Public Transport Routes as depicted on the Policies Map;
- x. the Borough Council will use mechanisms such as planning conditions and planning obligations, including financial contributions where necessary to secure the timely delivery of any necessary transport mitigation measures; and
- xi. development of transport infrastructure provision will be coordinated in line with the up to date Infrastructure Delivery Plan, which will be subject to regular review.”

2.3.7 The sustainable credentials and accessibility of the site are presented in Chapter 3 of this report, where it is demonstrated that the site is accessible and accords with relevant policy from WCC. In accordance with the BRLP, a TA and RTP has been provided in support of the proposed development scheme. Chapters 5, 6 and 7 of the TA demonstrate that the traffic associated with the proposed development would not have a severe impact on the local highway network.

Worcestershire Local Transport Plan 4 (LTP4)

2.3.8 The Worcestershire Local Transport Plan 4 (LTP4) covers the period from 2018 to 2030 and is a document which considers the short, medium- and long-term needs of the county and sets out a strategy to deliver these needs.

2.3.9 The LTP4 sets out the issues and priorities for investment in transport infrastructure, technology and services to support travel by all relevant modes of transport, including walking, cycling, rail, highways (car, van, freight and motorcycles), bus and community transport. The document also includes a vision for the county; it analyses travel problems and opportunities, and sets clear objectives and policies, in order to tackle the issues. It also includes a programme of transport interventions that will help to achieve these.

2.3.10 The LTP4 is underpinned by WCC's Corporate Plan 'Shaping Worcestershire's Future 2017 – 2022' with its four key priorities:

- Open for Business;
- The Environment;
- Children and Families; and
- Health and Well-being.

2.3.11 The LTP also reflects the Worcestershire Local Enterprise Partnership's vision for the county: "To build a connected, creative, dynamic economy that delivers increased prosperity for all those who choose to live, work, visit and invest in Worcestershire.

2.3.12 In order to complement the key themes of WCC's Corporate Plan, the vision of the LTP4 is guided by five main objectives:

- To support Worcestershire's economic competitiveness and growth through delivering a safe, reliable and efficient transport network.
- To limit the impacts of transport in Worcestershire on the local environment, by supporting enhancements to the natural environment and biodiversity, investing in transport infrastructure to reduce flood risk and other environmental damage, and reducing transport-related emissions of nitrogen dioxide, particulate matter, greenhouse gases and noise pollution. This will support delivery of the desired outcomes of tackling climate change and reducing the impacts of transport on public health.
- To contribute towards better safety, security, health and longer life expectancy in Worcestershire, by reducing the risk of death, injury or illness arising from transport and promoting healthy modes of travel.
- To optimise equality of opportunity for all of Worcestershire's citizens with the desired outcome of creating a fairer society.

- To enhance the quality of life for Worcestershire's residents by promoting a healthy, natural environment, for people, wildlife and habitats, conserving our historic built environment and preserving our heritage assets.

2.3.13 The LTP4 sets out a number of considerations specific to North East Worcestershire; which comprises the Bromsgrove District and Redditch Borough. The main challenges in North East Worcestershire are as follows:

- To enable and promote growth;
- To relieve congestion;
- To tackle air quality issues;
- To enhance transport network reliability and resilience;
- To improve all aspects of road safety.

2.3.14 The long-term themes of the West Midlands LTP4 aim to reduce reliance on the private car in favour of more sustainable modes of transport for many journey purposes, Chapters 3, 5 and 6 of this report demonstrate that the proposed development is sustainable and that the scheme would not have a significant impact on the surrounding area in terms of highways and parking. As such the proposed development is to be delivered in accordance with the relevant policy of the LTP4.

2.4 Summary

2.4.1 In summary the planning policy described above collectively seeks to ensure that development is located to ensure residents and visitors are provided with genuine modal choice by situating development in locations that reduce the need to travel, reduce average journey lengths and benefit from local infrastructure to enable use of modes of transport other than the single occupancy private car.

2.4.2 Furthermore, the planning policy considered also seeks to ensure that the impacts of the development are properly considered and mitigated via the preparation of appropriate transportation reports to accompany the planning application and where necessary the provision of mitigation in order to temper the impacts of a given development.

2.4.3 This TA and the corresponding RTP have been prepared in line with current best practice guidance and methodology.

3. Existing Conditions

3.1 Overview

3.1.1 This chapter considers the existing context of the development in relation to land use, local highway network and accessibility by various sustainable modes of transport.

3.2 Site Context

3.2.1 The site is located approximately 1.5km north of Redditch Town Centre, to the west of Hither Green Lane. The site is bound by Dagnell End Road to the north, Hither Green Lane to the east, the River Arrow to the south and Meadow Farm Public House to the west.

3.2.2 An overview of the site location is provided in **Figure 3.1**, for reference.

Figure 3.1 : Site Location



3.2.3 The site currently comprises of the north-western parcel of the existing golf course associated with The Abbey Hotel, as well an area of surface car parking which accommodates c. 16 spaces.

3.3 Local Highway Network

3.3.1 An overview of the local highway network in the vicinity of the site is provided in **Figure 3.1**.

Hither Green Lane

3.3.2 In the vicinity of the site the road is a single carriageway, covered by street lighting and has a 30mph posted speed limit.

3.3.3 The road is a residential loop, which connects with Dagnell End Road via two priority junctions, and provides access to a number of residential cul-de-sacs, in addition to The Abbey Hotel and golf course. South of the existing site access, the road incorporates build-out features, which narrow the carriageway width and act as a traffic calming feature on the approach to the residential dwellings. In the vicinity of the site, footway provision is continuous along the western side of the carriageway. This is lit and of good quality, providing suitable and convenient opportunities for access on foot.

Dagnell End Road (B4101)

3.3.4 Dagnell End Road forms the northern boundary of the site and provides connections between the signalised junction with Birmingham Road (A441) to the west and the priority controlled crossroads with Icknield Street and Church Hill to the east. Intermittent footway provision is provided along the southern side of the carriageway; which is largely concentrated in the vicinity of the signalised junction with Birmingham Road.

3.3.5 In the vicinity of the existing priority junctions with Hither Green Road, Dagnell End Road is subject to the national speed limit. This decreases to a 40mph speed limit, approximately 30m east of the signalised junction with Birmingham Road and approximately 175m west of the priority controlled crossroads with the Icknield Street and Church Hill.

Birmingham Road (A441)

3.3.6 Birmingham Road (A441) is situated approximately 250m west of the site, and can be accessed from Dagnell End Road via the connection with Hither Green Lane. The road is subject to a 40mph speed limit and provides connections north and south between Junction 2 of the M42 and Redditch Town Centre respectively.

3.3.7 In the vicinity of the junction with Dagnell End Road, footway provision is continuous along the eastern side of the carriageway, with intermittent provision also provided along the western side of the carriageway. This is lit and of good quality, providing connections towards the surrounding local residential areas.

3.4 Planning Context

3.4.1 The site is situated approximately 500m east of the live application (ref: 19/00976/HYB) for the development of third phase of Brockhill East; this will provide c. 950 dwellings along with a new primary school and local centre, across four phases. The hybrid application seeks planning permission for a total of 960 dwellings, of which 128 are subject a full application, with the remaining 832 subject to an outline application.

3.4.2 The application site covers the remaining components of two strategic allocations contained within the Bromsgrove District Plan and Redditch Local Plan (RCBD1 and Policy 46 respectively). Once completed these allocations are anticipated to deliver the following:

- RCBD 1 – around 600 dwellings which will integrate within the strategic site at Brockhill East and should integrate well into the existing urban fabric of Redditch; and
- Policy 46 – around 1,025 dwellings, 8.45 hectares of employment and relevant community facilities and services including a district centre (including convenience retail store), a first school and a sustainable public transport network.

3.4.3 As detailed within the planning statement (ref: P18-1328) submitted as part of the live application (ref: 19/00976/HYB) for Brockhill East Phase 3, the majority of which are located to the south of the Phase 3 application site. The Brockhill East Phase 3 application consists of the remaining component of the two strategic local plan allocations that has yet to be consented or constructed.

3.4.4 The application (ref: 19/00976/HYB) is currently marked as awaiting decision; however, it is noted that WCC; in their capacity as LHA, have undertaken a full review of the planning application and subsequently raise no objections. Given the site's status as the final part of a strategic allocation in the Bromsgrove District Plan and Redditch Local Plan, and the approved position from the LHA, Brockhill East Phase 3 has been considered as a committed development in the modelling section of this TA. Consideration has also been made of the potential highway mitigation / improvement measures within the TA, in order to ensure the proposed development at Hither Green Lane takes account of any amendments to the surrounding highway network.

3.4.5 An overview of the site in the context of the committed development is provided in **Figure 3.2**.

Figure 3.2 : Planning Context – Brockhill East Phase 3 (ref: 19/00976/HYB)



3.4.6 The committed Brockhill East Phase 3 scheme includes mitigation works to be implemented at the Dagnell End Road / Birmingham Road signalised junction. The mitigation scheme will provide additional capacity at the junction, in addition to wider benefits to the community through the establishment of a signal-controlled pedestrian crossing. The scheme also includes an extension and widening of the existing footway provision along the southern side of Dagnell End Road between the signalised junction and the existing postbox on the southern side of the carriageway. This new section of footway is to be provided to the rear of the highway land in order to avoid existing utilities and retain an existing mature oak tree.

3.4.7 The mitigation scheme is outlined in PJA drawing 2809-P-12-P4, attached as **Appendix B** for reference. The scheme has been designed on topographical survey data and has been deemed acceptable by WCC for the purpose of granting planning permission, however this is still subject to technical approval and Road Safety Audits (RSAs) to support the detailed design stage.

3.5 Existing Baseline Traffic Flows

3.5.1 In the absence of being able to conduct traffic surveys as a result of Covid-19 pandemic, traffic flows have been obtained from the TA associated with the Brockhill East site (PJA TA 'Land at Brockhill East' Phase 3 June 2019) and from the TA associated with the previous planning application on Hither Green Lane (Travis Baker TA 'Hither Green Lane, Redditch'; Ref: T16033/TA/01). This is discussed in detail in Chapter 6.2.

3.6 Highway Safety

3.6.1 PPG states that Transport Statements should consider the most recently available three-year period of collision data, unless a high collision rate has been identified. For completeness, a review of collision data for the most recently available five-year period has been undertaken.

3.6.2 Collision data has been obtained from WCC's Traffic and Accident Data Team for the most recent five-year period available (2015 - 2020). An overview of the study area and the recorded collisions is provided in **Figure 3.3**, for reference. The full details of the recorded collisions, including the severity and location are attached as **Appendix C**, for reference.

3.6.3 The findings indicate a total of 11 collisions were recorded within the study area between 2015 and 2020, with 9 recorded as 'slight' and 2 recorded as 'serious' in severity.

Figure 3.3 : Collision Study Area



3.6.4 The first of the serious collisions occurred in August 2019 at the Dagnell End Road / A441 signalised junction, during daylight hours in dry weather conditions. The junction was operating with road works and temporary traffic management in place which changed the standard operation of the junction. The accident was attributable to the driver error with the vehicle trying to turn right from Birmingham Road onto Dagnell End Road which was limited to an 'access only' due to the traffic management.

3.6.5 The collision was not attributed to the permanent road layout at the junction and therefore it is not considered that this represents a highway safety issue that would likely be exacerbated by the development. It should also be noted, that a highway improvement scheme is being delivered by the Brockhill East development at this location to improve the operation of the junction.

- 3.6.6 The second serious collision recorded within the study area occurred in the vicinity of the access from Dagnell End Road to the Meadow Farm Pub. The accident involved a goods vehicle (7.5 tonnes and over) and a car. From the accident report, it appears the goods vehicle was in the act of turning right at the public house junction, and a car passing another moving vehicle on its offside collided with the front of the goods vehicle. The collision has been attributed to driver error and does not therefore represent a highway safety issue that would likely be exacerbated by the development.
- 3.6.7 A small cluster of three slight collisions was recorded on the A441 (southern) approach to the Millrace Road / B4184 / A441 roundabout. All of these collisions were attributed to driver error and are not therefore considered to represent a highway safety issue that would likely be exacerbated by the development.
- 3.6.8 The majority of other slight collisions within the study area have been recorded along major local routes to and from the centre of Redditch. These routes are typically subject to high volumes of through traffic. Higher levels of collisions are often recorded at or close to junctions and routes which are subject to high volumes of traffic.
- 3.6.9 No collisions have been recorded in the vicinity of the site access onto Hither Green Lane.
- 3.6.10 In light of the above there are not considered to be any unusual patterns or trends of recorded collisions observed in the study area. Both of the serious collisions occurred as a result of driver error and were not attributed to road design. The majority of the slight collisions occurred along major routes, subject to high volumes of through movements and no collisions were recorded in the vicinity of the proposed site access. It is not therefore considered that there are any inherent highway safety issues on the local highway network surrounding the site which would likely be exacerbated by the development.

3.7 Sustainable Access

- 3.7.1 This section of the report considers accessibility of the site by walking, cycling and public transport.

Walking

- 3.7.2 The site is located adjacent to existing residential properties along Hither Green Lane and therefore benefits from an established network of lit, good quality footway provision along the site frontage.

- 3.7.3 The existing footway provision is limited along Dagnell End Road, with wide grass verges on both sides of the carriageway and a narrow footway (c.1.0m width) on the southern side of the carriageway for c.100m from the Birmingham Road (A441) / B4101 Dagnell End Road junction.
- 3.7.4 As part of the Brockhill East Phase 3 scheme (ref: 19/00976/HYB) a mitigation scheme is to be implemented at the Dagnell End Road / Birmingham Road signalised junction. This includes the establishment of a signal-controlled pedestrian crossing at the junction. The scheme also includes extension and widening of the existing footway provision along the southern side of Dagnell End Road between the signalised junction and the existing postbox on the southern side of the carriageway. The mitigation scheme is outlined in PJA drawing 2809-P-12-P4, attached as **Appendix B** for reference.
- 3.7.5 Immediately to the south of the site, a publicly accessible path provides a connection from Hither Green Lane through the golf course, towards the A441. The existing footway running alongside the A441 Birmingham Road towards Redditch is in good condition and is covered by street lighting.
- 3.7.6 The existing underpass near the Abbey Stadium provides a suitable crossing point, enabling pedestrians to reach the Abbey Retail Park and / or continue towards the town centre. Further crossings (in the form of pedestrian refuge islands and tactile paving) are also present at the A441 / Weights Lane / Odell Street roundabout and just south of the Birmingham Road / Alfrick Close junction which provide access to the residential areas on the western side of the A441. A signalised crossing point is also provided at the Birmingham Road / Windsor Road junction to the west.
- 3.7.7 To the southeast of the site, an additional publicly accessible path provides a further connection through the golf course, from the existing footway provision along Hither Green Lane. This footpath connects with a number of well-established Public Rights of Way (PRoW) which provide onward pedestrian routes east towards the existing residential areas along Paper Mill Drive (namely the 815(B) PRoW), as well as south towards the residential areas along Forge Mill Road (namely the 511(B) and 517(C) PRoW). To the north of Dagnell Road, PRoW 628(C) provides a rural route towards the village of Rowney Green.
- 3.7.8 Analysis has been undertaken to determine the areas which can be accessed within a 20-minute walking distance of the site. An overview of this exercise, illustrating a 20-minute walking isochrone from the site, is shown in **Figure 3.4**.

Figure 3.4 : 20 Minute Walking Isochrone

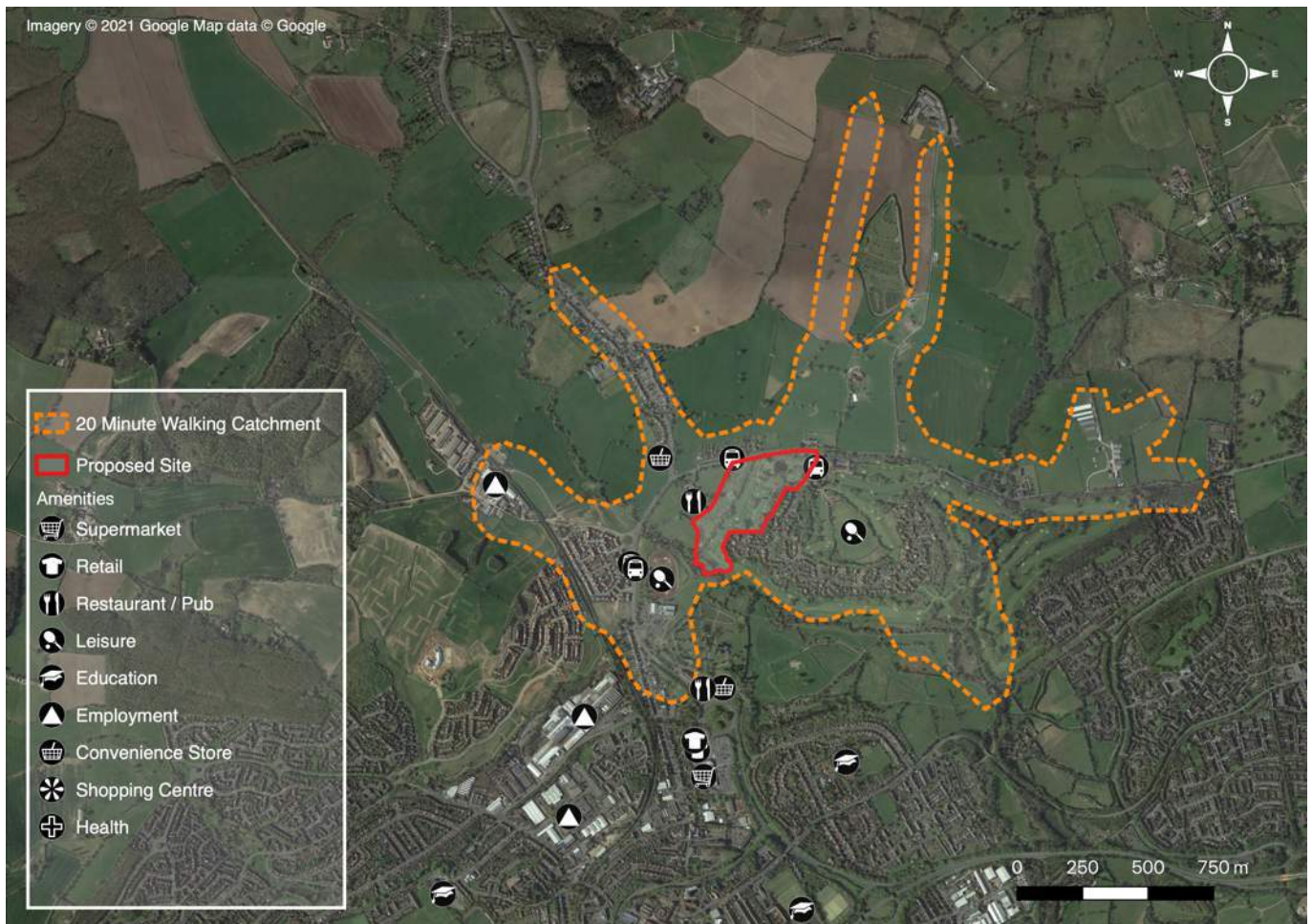

3.7.9 The isochrone analysis demonstrates that the site is within an accessible walking catchment of existing residential areas. In addition to this, the bus services operating from the stops along Dagnell End Road and Birmingham Road are also located within this isochrone and a short walk of the site. The bus services operating from these stops are discussed in greater detail in the subsequent section.

Cycling

3.7.10A number of local cycle routes, along with sections of the National Cycle Network (NCN) can be accessed within close proximity of the site, linking the site with the wider areas of Redditch Borough. An extract from WCC's online cycle map, showing the cycle network in the context of the site location, is provided in **Figure 3.5**.

Figure 3.5 Extract of WCC Redditch Cycle Routes Map

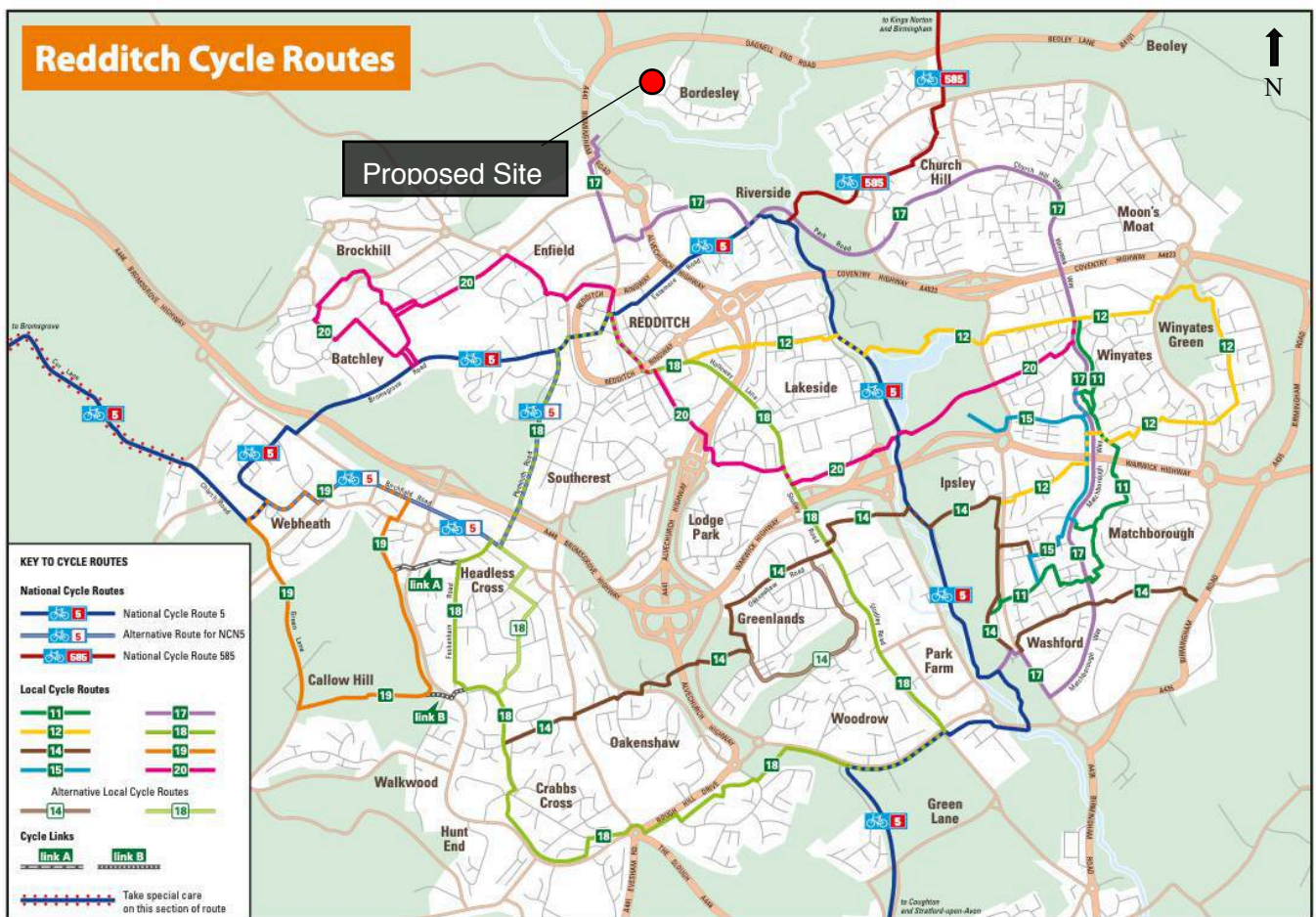

© Worcestershire County Council

3.7.11A network of both on and off-road cycle routes provide connections east, south and west through the surrounding residential areas and towards a variety of services and amenities in and around Redditch Town Centre. These routes can be accessed along the Birmingham Road (A441), via the existing lit and tarmac-surfaced route adjacent to the River Arrow and the publicly accessible routes through the golf course to the southwest of Hither Green Lane. Cyclists may be required to dismount along these routes when accessing the Birmingham Road (A441) from the site.

3.7.12 There are two NCN routes running nearby to the site. NCN Route 5 runs approximately 1.5km south of the site and provides connections locally from east to west through Redditch Town Centre and through the residential areas of Enfield and Batchley, before continuing on towards Bromsgrove. To the south, the NCN Route 5 route provides connections adjacent the River Arrow and links with a number of local cycle routes to the south of the town centre, before continuing on towards Stratford-upon-Avon.

3.7.13 NCN route 585 runs approximately 1.85km east of the site, and provides connections locally from the Riverside Area where it continues as Route 55 north towards Kings Norton. From here the route re-joins NCN route 5, providing connections to Birmingham City Centre.

3.7.14 Analysis has been undertaken to determine the areas which can be accessed within a 20 minute cycle of the site. An overview of this exercise, illustrating a 20-minute cycling isochrone from the site, is shown in **Figure 3.6**.

Figure 3.6 : 20 Minute Cycling Isochrone

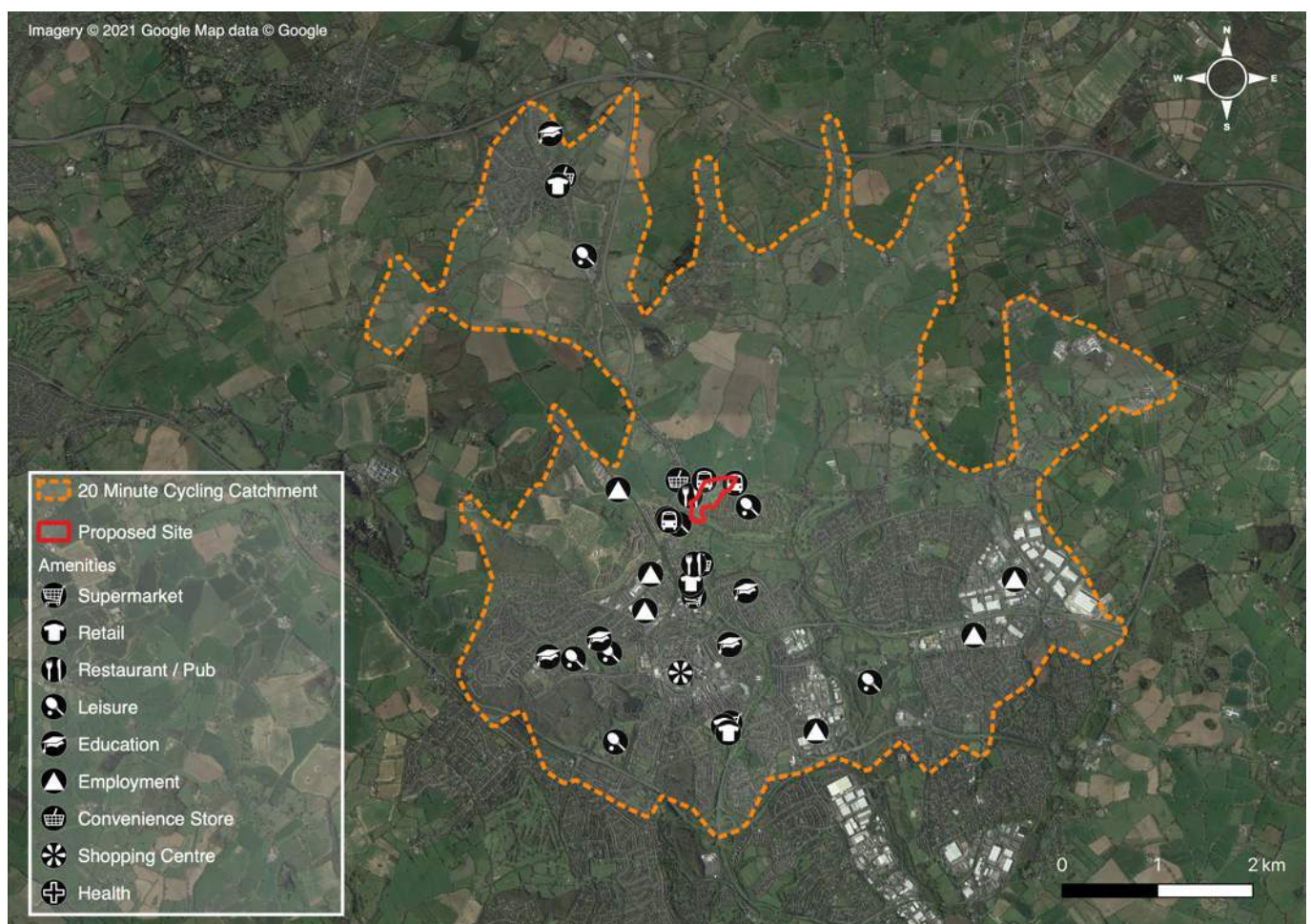

3.7.15 As outlined above, the analysis demonstrates that the site is situated within an accessible cycling distance of several large residential areas, in addition to Redditch Town Centre. The location of the site and proximity to amenities and employment opportunities in Redditch Town Centre provides potential for journeys to be undertaken via bicycle to and from the site.

3.8 Public Transport

Bus Services

3.8.1 The location of the bus stops and services available in the vicinity of the site are shown in Figure 3.7.

Figure 3.7 : Location of Bus Services

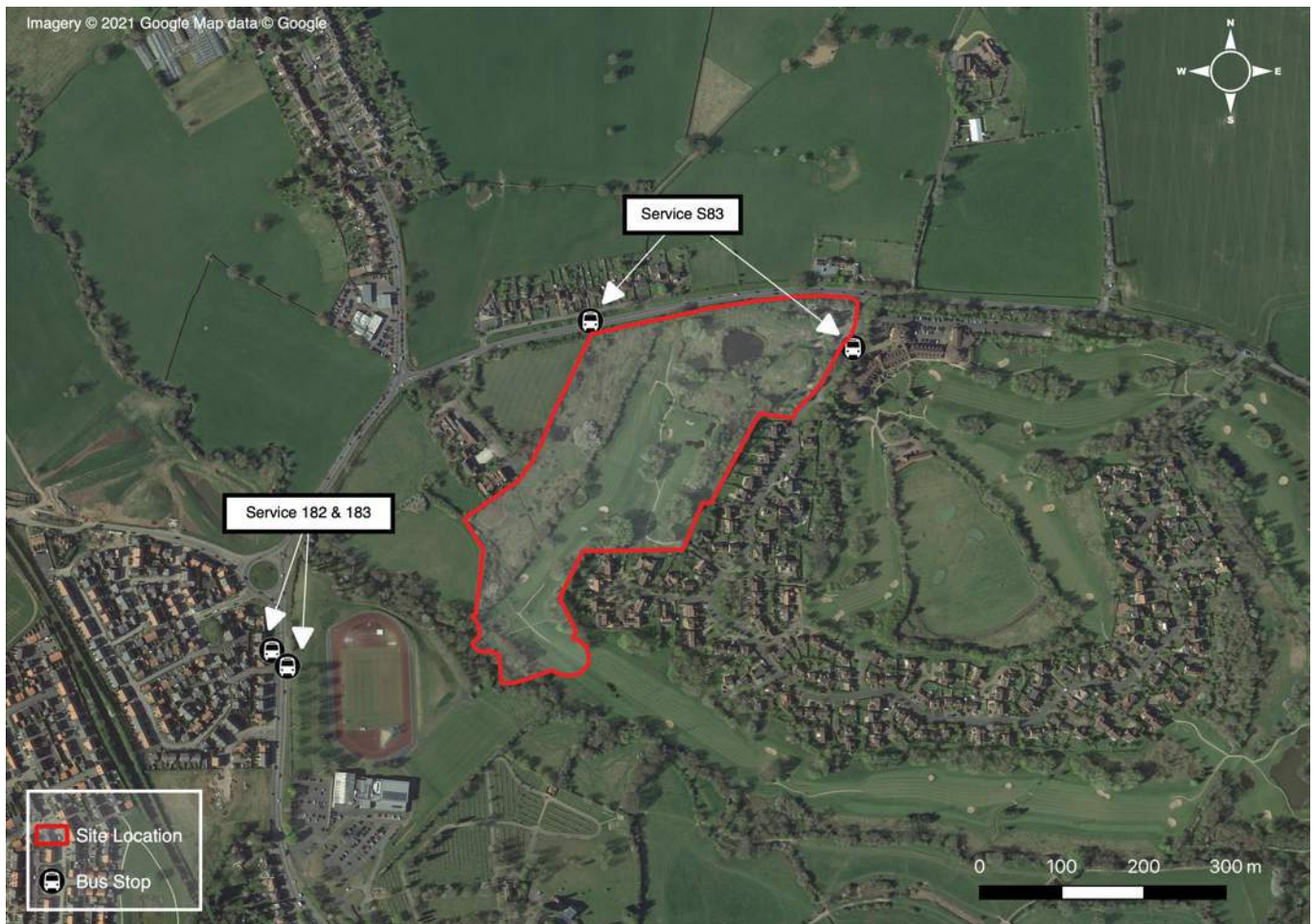

3.8.2 The nearest bus stops to the site are located immediately adjacent to the site on Hither Green Lane at The Abbey Hotel and Dagnell End Road (c.300 metres to the west of the Hither Green Lane / Dagnell End Road junction). Services are limited from both stops with the S83 (from both stops) and the S55 (The Abbey Hotel bus stop) offering one service a day to the centre of Redditch.

3.8.3 Further bus services are accessible on A441 (Birmingham Road) within c.500 distance (c.6-minute walk) of the site and can be accessed via the pedestrian link to the River Arrow, and the subsequent connection with the footway provision along Birmingham Road. The Nos. 182 and 183 services are accessible from the stop on the A441 (Birmingham Road) which each offer one service a day on weekdays from Bromsgrove, Lickey, Alvechurch and onto Redditch.

3.8.4 The Brockhill East Phase 3 scheme (ref: 19/00976/HYB) includes an in-principle agreement for the applicant to provide a Section 106 contribution towards a new circular bus service between Brockhill East and Redditch town centre. The circular service will operate via the bus station and could potentially enhance accessibility in the vicinity of the proposed development at Hither Green Lane, via connections at the Weights Lane roundabout, to the west of the site.

Rail Services

3.8.5 The closest station to the site is Redditch Railway Station, which is located c.2.8km to the south west of the site, accessible within an approximate 35-minute walk or 12-minute cycle. The station benefits from the provision of 18 bicycle storage spaces, covered by CCTV.

3.8.6 All services at Redditch Railway Station are operated by West Midlands Railway. The station forms the southern terminus of the Cross City Line to Barnt Green. A summary of the destinations accessible and from Redditch Railway Station and the typical journey times is provided in **Table 3.1** below.

Table 3.1 : Summary of Services from Redditch Railway Station

Destination	Typical Peak Hour Frequency	Approximate Journey Time
Birmingham New Street	2 an hour	36 minutes
Four Oaks	2 an hour	1 hour 3 minutes

3.8.7 Bicycles are permitted on services operating from Redditch, with 2 cycle spaces available on each service. Folding bicycles are permitted on all services.

3.9 Proximity to Local Services and Facilities

- 3.9.1 It is imperative to consider the potential opportunities for access to local amenities. In transport planning terms, the most sustainable sites are those generating the lowest number of single occupancy private vehicle trips, which can be achieved by facilitating a greater proportion of walking, cycling and public transport journeys.
- 3.9.2 Planning guidance highlights the emphasis being placed on the integration of land use, transport and planning decisions. In order to achieve good integration, developments should be encouraged in areas with good accessibility to local facilities, employment opportunities and public transport. This section demonstrates the amenities, employment and education facilities that can be accessed from the site by sustainable modes, as well as describing the existing public transport, pedestrian and cycle connections.
- 3.9.3 The Institute of Highways and Transportation's (IHT) 'Guidelines for Providing Journeys on Foot' (2000) provides guidance when considering accessibility of specific locations by foot. In relation to the proposed development, the guidelines suggest:
- Maximum distances of 800m to town centres, 2,000m for work / education / leisure, and 1200m elsewhere;
 - Acceptable distances of 400m to town centres, 1,000m for work / education / leisure, and 800m elsewhere; and,
 - Desirable distances of 200m to town centres, 500m for work / education / leisure, and 400m elsewhere.
- 3.9.4 Cycling is also considered to be a highly sustainable mode of travel and generally journeys up to 8km are considered an achievable distance for most people (LTN 01/20 Cycle Infrastructure Design).
- 3.9.5 In respect of acceptable cycle distances, 'Local Transport Note 1/20: Cycle Infrastructure Design' published by DfT, states that 'two out of every three personal trips are less than five miles in length – which is an achievable distance to cycle for most people'.
- 3.9.6 The site is well served by a range of community, health, education and retail facilities all within the recommended walking distances detailed above. These can also be considered to be accessible by cycling and public transport. The edge of Redditch Town Centre is within 2km of the site which provides a substantial range of amenities.

3.9.7 Furthermore, as stated above, the site is located approximately 500m east of the strategic allocation at Brockhill East. The live application for Phase 3 (ref: 19/00976/HYB) includes a primary school and a local centre, which will be accessible via active modes of travel (walking / cycle) from the site.

3.9.8 A range of the existing local facilities and amenities can be accessed within a walking distance of 2km or less from the centre of the site via the proposed and existing footway provision on Dagnell End Road and the footway to the south of the site, both connecting to the A441. These include schools, shops, employment sites and recreation facilities. Further details in respect of amenities and the walking / cycle time to each is provided below in **Table 3.2**.

Table 3.2 : Local Service and Facilities

Facility	Distance (m)	Walk Time (Mins)	Cycle Time (Mins)
Marks & Spencer Food Store	450	6	2
Nunnerly of Redditch (Garden Centre)	800	10	3
Abbey Stadium	850	11	3
Weights Farm Business Park	1,300	16	5
Redditch Beefeater	1,300	16	5
B+M Home Store & Garden Centre	1,500	19	6
Sainsburys Supermarket	1,600	20	6
St Stephens C of E First School and Nursery	1,700	21	7
Trinity High School and Sixth Form Centre	2,400	30	10
Kingfisher Shopping Centre	2,500	31	10

3.10 Existing Modal Journey Share

3.10.1 In order to forecast the modal share for the residents at the site, the 2011 Census data relating to the method of travel to work for residents living in the Mid-Layer Super Output Area (MSOA) – Redditch 001: E02006721 has been interrogated.

3.10.2 A summary of the 2011 mode share of residents living in the MSOA is shown in **Table 3.3**.

Table 3.3 : Residents Method of Travel to Work – 2011 Census Data (Redditch 001: E02006721)

Method of Travel to Work	Mode Share (%)
Driving a car or van	78%
Passenger in a car or van	6%
Bicycle	2%
On foot	6%
Bus, minibus or coach	5%
Rail	2%
Other	1%
Total	100%

3.11 Summary

3.11.1 The level of accessibility to the site is considered to be good with a range of opportunities for sustainable travel, by walking and cycling, with some limited existing public transport provision.

3.11.2 Analysis of the local highway network in the vicinity of the site has demonstrated that there are not any inherent highway safety issues on the local highway network surrounding the site which would likely be exacerbated by the development.

4. Development Proposals

4.1 Overview

4.1.1 The proposed scheme comprises of 216 dwellings, which will be a mix of privately owned and affordable dwellings, along with associated infrastructure and open space. A copy of the illustrative masterplan for the site is attached at **Appendix A**, for reference.

4.2 Vehicular Access

4.2.1 Vehicular access will be provided via a new priority crossroads junction along the site's eastern frontage, formed with Hither Green Lane and the unnamed access road serving the golf range on the opposite side of the road. The connection between the site and Hither Green Lane has been designed in accordance with Manual for Streets (MfS) and WCC's Streetscape Design Guide (2020).

4.2.2 The site access will incorporate a 5.5m wide carriageway width, with 10m corner radii and 2m wide footways on both sides of the carriageway. Pedestrian access at the junction will be supported by the provision of an uncontrolled crossing facility, in the form of dropped kerbs/ tactile paving. An overview of the access arrangements for the site are provided in Drawing J32-5756-PS-001, attached at **Appendix D**, for reference.

4.2.3 A tracking assessment has also been undertaken for the site access, which demonstrates that a Mercedes Econic refuse vehicle (11.7m) and Fire Tender (8.6m) can access and egress the site without conflict. Tracking assessments for the sites access are provided in Drawing J32-5756-PS-002 and Drawing J32-5756-PS-003, attached at **Appendix D**, for reference.

4.2.4 Appropriate visibility splays have been provided at the site access in accordance with the posted speed limit of 30mph, along Hither Green Lane, in the vicinity of the site access. In accordance with the requirements set out within MfS, 43m visibility splays at a 2.4m setback from the give-way line have been shown (based on 30mph). The access and visibility splays are shown in Drawing J32-5756-PS-001, attached at **Appendix D**, demonstrates that access junction for the site can achieve the required visibility splays, and therefore conforms with guidance set out within MfS.

4.3 Emergency Access

4.3.1 On account of the scale of development proposed, an alternative point of access into the site will be provided for emergency vehicles.

- 4.3.2 MfS indicates that the access requirement for emergency vehicles are generally stipulated by the Fire Service. Consulting national guidance, The Building Regulations 2010 'Fire Safety' (2019 edition incorporating 2020 amendments) Approved Document B Section 5 'Access and Facilities for the Fire and Rescue Service', at Table 13.1 of the document identifies that 'typical fire and rescue service vehicle access route specification' stipulates that a minimum road width of 3.7m should be provided.
- 4.3.3 Emergency access will be provided on to Dagnell End Road at the western end of the site frontage, in the form of a 3.7m wide pedestrian link, with retractable bollards to prevent private vehicle access. An overview of the emergency access arrangements for the site is provided in Drawing J32-5756-PS-004, attached at **Appendix D**.
- 4.3.4 A tracking assessment has also been undertaken for the emergency vehicle access, which demonstrates that a Fire Tender (8.6m) can access and egress the site via the emergency access point. The tracking assessment for the emergency access junction is provided in Drawing J32-5756-PS-005, attached at **Appendix D**, for reference.

4.4 NMU Access

Proposed Development

- 4.4.1 As outlined in the illustrative masterplan attached at **Appendix A**, connections between the site and the surrounding highway network will be provided to the northern and eastern frontages of the site.
- 4.4.2 In order to encourage travel to and from the site by sustainable modes of transport, the proposed development will include the following infrastructure:
- To the north of the site, a pedestrian route will link the site with Dagnell End Road.
 - A new section of footway will also be provided on the southern side of Dagnell End Road, within the existing highway boundary. This will connect with the existing footway on the southern side of Dagnell End Road, providing a connection west towards the existing footway network along Birmingham Road (A441). This will be subject to confirmation of land ownership and discussions with WCC in order to agree an appropriate mechanism to tie this into the footway improvements associated with Brockhill East Phase 3;
 - To the south and west pedestrian / cycle connections will be provided with the existing NMU connection which runs alongside the River Arrow and connects with Birmingham Road immediately north of the river over-bridge. This will provide a direct and attractive route to the local facilities and amenities in the vicinity of the site.

4.4.3 An overview of the proposed accessibility enhancements for NMUs in the vicinity of the site is provided in **Figure 4.1**. This is shown in the context of the existing NMU route along the River Arrow, and the footway improvements along Dagnell End Road to be delivered as part of the committed scheme at Brockhill East.

Figure 4.1 : Accessibility Improvements



4.5 Public Transport

4.5.1 It is considered that the additional footway provision within the site will enhance accessibility to the various bus services operating within the vicinity of the site. The bus stops along Hither Green Lane and Dagnell End Road are located within a c. 200m crow-fly distance (2.5 minute walk) of the majority of the site, and will be accessible via the new pedestrian links to the east and north respectively.

4.5.2 To the west of the site, the bus stops along Birmingham Road are located within a c. 400m crow-fly distance (5 minute walk) of the site. Connections to these bus stops will be promoted via the new pedestrian connections with the existing lit footway provision along the River Arrow, and the subsequent connection with the footway provision along Birmingham Road.

4.6 Parking

4.6.1 In terms of the level of parking required on site, parking will be provided in accordance with the relevant parking standards set out within WCC's Streetscape Design Guide (2020). The document outlines the following minimum requirements for car and cycle parking:

- 1 bedroom unit: 1 vehicle space & 1 cycle space;
- 2-3 bedroom units: 2 vehicle spaces & 2 cycle spaces; and
- 4-5 bedroom units: 3 vehicle spaces & 2 cycle spaces.

4.6.2 The application is being submitted in outline form with all matters reserved apart from access, therefore the final quantum of parking will be determined at the Reserved Matters stage.

5. Forecast Traffic Generation and Distribution

5.1 Overview

5.1.1 This chapter considers the traffic impact of the proposed development, with consideration of the peak hour trip generation and the distribution of traffic onto the local highway network.

5.2 Trip Rates

5.2.1 In order to provide an indication of the potential traffic impact of the proposed scheme, data has been obtained from the TRICS (V7.8.1) database for developments from the 'Residential – Houses Privately Owned' (03/A) land use category. Sites of similar scale and geographic setting have been included in the data samples. Sites located in Greater London, Scotland, Wales and Ireland have been excluded. The full TRICS search outputs are included as **Appendix E**, for reference.

5.2.2 Alternative trip rates have also been sourced from the TA for the live application (ref: 19/00976/HYB) for Brockhill East Phase 3. The trip rates presented as part of the TA were obtained from automatic traffic counts undertaken at the Brockhill Phase 1 site (where construction has been completed) in October 2018, which comprised a total of 216 dwellings.

5.2.3 It is acknowledged that these trip rates have been obtained from the TA for an application which is still pending, however WCC have issued a response of no objection, and stated the following in relation to the trip rates in their latest representation (January 2021) in relation to the planning application:

“The Highway Authority believes this to be a suitable means in which to identify trip generation and accept that the results are robust. As the trip rates are based on surveys of a site that is still yet to build a district centre, school, or be served by public transport routing through the site, and as such, the trip rates will reflect higher car trips than anticipated when the amenities are in place.”

5.2.4 A comparison of the two sets of trip rates is provided in **Table 5.1** covering the traditional highway network weekday morning (08:00-09:00) and afternoon (17:00-18:00) peak periods.

Table 5.1 : Trip Rates

Land Use	Weekday AM Peak (08:00-09:00)			Weekday PM Peak (17:00-18:00)		
	Arrivals	Departures	Two-Way	Arrivals	Departures	Two-Way
03 / A (per dwelling) - TRICS	0.128	0.366	0.494	0.336	0.153	0.489
Surveyed Trip Rates (per dwelling)	0.182	0.524	0.706	0.501	0.249	0.750

5.2.5 As set out above, the trip rates taken from the donor site at Brockhill East Phase 1 are greater than those obtained from the TRICS database. It is therefore proposed to use the trip rates from the donor site as part of the TA for the proposed development. It is considered that this will provide a robust assessment of the potential traffic impact of the proposed development.

5.3 Trip Generation

5.3.1 Taking into account the trip rates from the donor site outlined above, **Table 5.2** provides an overview of the forecast trip generation associated with the proposed development based on 216 dwellings.

Table 5.2 : Trip Generation

Land Use	Weekday AM Peak (08:00-09:00)			Weekday PM Peak (17:00-18:00)		
	Arrivals	Departures	Two-Way	Arrivals	Departures	Two-Way
Surveyed Trip Rates (per dwelling)	0.182	0.524	0.706	0.501	0.249	0.750
Trip Generation (216 Dwellings)	39	113	152	108	54	162

5.3.2 As set out in **Table 5.2**, the proposed scheme is forecast to generate approximately 152 additional two-way trips during the AM peak and 162 two-way trips during the PM peak; which equates to approximately 3 additional trips per minute on the local highway network during the respective peak hours.

5.4 Traffic Distribution

5.4.1 A traffic distribution exercise has been undertaken based on the distribution profile for the Brockhill East residential development, which has been deemed acceptable by WCC. The distribution exercise included within the TA for the Brockhill East residential development was calculated via 2011 Census Journey to Work data, and assigned to the network based upon analysis of a combination of Google Maps, local knowledge and ArcGIS online journey planning software.

5.4.2 Taking into account the trip distribution profile obtained from the TA for the adjacent committed development, the local road network has been analysed and traffic has been distributed to the zones shown in **Figure 5.1**.

Figure 5.1 : Traffic Distribution Zones



5.4.3 A summary of the trip distribution and the resulting trip generation during the respective AM and PM peak periods is outlined in **Table 5.3** and shown diagrammatically in the traffic flow diagrams, attached as **Appendix F**, for reference.

Table 5.3 : Traffic Distribution Profile

Zone	Distribution (%)	AM Peak (08:00 – 09:00)		PM Peak (17:00 – 18:00)	
		Arrivals	Departures	Arrivals	Departures
A – Redditch Road (North of Redditch Road / A441 Roundabout)	0%	-	-	-	-
B – Birmingham Road (A441) (North of Redditch Road / A441 Roundabout)	51%	20	58	55	28
C – Dagnell Road (East of site)	6%	2	7	6	3
D – A4023 (East of A441 / A4023 Roundabout)	14%	5	16	15	8
E – A441 Alvechurch Highway (South of A441 / A4023 Roundabout)	16%	6	18	17	9
F - A4023 (West of A441 / A4023 Roundabout)	8%	3	9	9	4
G – Windsor Road (West of A441 / Middlehouse Lane Roundabout)	5%	2	6	5	3
H – Weights Lane (West of A441 / Weights Lane)	0%	-	-	-	-

6. Junction Analysis

6.1 Introduction

6.1.1 This chapter describes the junction capacity assessments carried out in order to determine the suitability of the proposed site access junction, in addition to off-site junctions where a material impact is forecast. A future year assessment of 2030 has been used to be consistent with adjacent committed schemes.

6.2 Traffic Flows

Brockhill East – Traffic Flows

6.2.1 In the absence of being able to conduct traffic surveys as a result of Covid-19 pandemic, traffic flows have been obtained from the Transport Assessment associated with the Brockhill East site (PJA TA 'Land at Brockhill East' Phase 3 June 2019), located immediately south of Weights Lane, for the following junctions:

- A441 / Dagnell End Road (signal T junction);
- A441 / Weights Lane / Odell Street (roundabout);
- A441 / Retail Access / Middlehouse Lane (roundabout);
- A441 / Redditch Ringway (signal T junction); and
- A441 / A4023 (roundabout).

6.2.2 It should be noted that individual flow components (i.e base year flows, committed development flows) were not provided separately. The available datasets instead covered the '2030 + committed development' scenario and the development flows associated with the Brockhill East site. Consequently, these datasets have been combined to provide an effective '2030 Base' scenario.

Hither Green – Traffic Flows

6.2.3 Traffic flows have also been obtained from the TA associated with the previous planning application on Hither Green Lane (Travis Baker TA 'Hither Green Lane, Redditch'; Ref: T16033/TA/01) for the following junction:

- Dagnell End Road / Hither Green Lane (T-Junction).

6.2.4 The TA included raw turning count data for 2016 which has been taken forward in within this assessment. The committed development flows from Brockhill East have been added to this junction and subsequently growthed to 2030 using TEMPro.

6.2.5 With regards to the committed development flows that would travel through this junction, it was only possible to apply the traffic identified from the Brockhill Phase 4 scheme. The traffic associated with the other committed development, whilst applied to the other offsite junctions, were not highlighted at this junction. However, based on the location and likely distribution, most trips would be routed along Birmingham Road and the associated TEMPro growth rates used at this junction would account for any background growth associated with the committed schemes.

6.2.6 The 2016 data has been growthed to a 2030 scenario using factors obtained from TEMPro. TEMPro factors have been obtained for the area 'Redditch 001' using the TEMPRO V7.2b (NTM AF15) database, shown in **Table 6.1** below.

Table 6.1 : TEMPro Growth Factors – Redditch 001

Time Period	2016 to 2030 Growth Factor
Weekday AM Peak Period	1.093868
Weekday PM Peak Period	1.093117

6.2.7 The resultant 2030 future base year flows are shown diagrammatically in the traffic flow diagrams, attached as **Appendix F**, for reference.

6.3 Assessment Scenarios

6.3.1 For the purpose of the proposed application, the following scenarios have been considered within the assessments:

- 2030 Base (effective) AM and PM Peaks; and
- 2030 Base (effective) + Development AM and PM Peaks.

6.4 Development Impact at Junctions – Screening

6.4.1 Junction capacity analysis included as part of the TA ('Land at Brockhill East' Phase 3 June 2019') for the adjacent Brockhill East site included the following junctions along the adjacent A441 corridor:

- A441 / Dagnell End Road (signal T junction);
- A441 / Weights Lane / Odell Street (roundabout);
- A441 / Retail Access / Middlehouse Lane (roundabout);
- A441 / Redditch Ringway (signal T junction); and;
- A441 / A4023 (roundabout).

6.4.2 In this regard it should be noted that the modelling for Brockhill East Phase 3 included a significantly greater quantum of development (c. 950 dwellings and a primary school) when compared with the proposed development of 216 dwellings at Hither Green Lane. In order to determine which junctions within the study area should be included for detailed assessment along the A441 corridor, mode has carried out a two stage ‘screening’ approach.

6.4.3 Consideration has also been made of the impact at the Hither Green Lane / Dagnell End Road priority junction which provides access from the site (via Hither Green Lane) to the wider highway network.

Stage 1 Screening

6.4.4 Stage 1 screening is based on the traditional DfT Guidance for Transport Assessment (GTA) approach to assessment. Despite the GTA guidance being replaced in 2014, its replacement Transport Evidence Bases in Plan Making is not a like-for-like document, providing no guidance on the production of Transport Assessments. It is commonly accepted by other practitioners that GTA still represents industry best-practice and remains relevant.

6.4.5 The traditional GTA 30 two-way trip threshold for capacity assessment is applied at Stage 1. Assigning development traffic to the local road network (as outlined in Section 5.4), **Table 6.2** identifies those junctions which exceed the threshold and are then taken through to Stage 2 screening.

Table 6.2 : Stage 1 Screening – GTA 30 Two-Way Threshold

Junction	Development Traffic (AM)	Development Traffic (PM)	Include at Stage 2?
Hither Green Lane / Dagnell End Road (priority T junction)	152	162	Yes (>30)
A441 / Dagnell End Road (signal T junction)	143	152	Yes (>30)
A441 / Weights Lane / Odell Street (roundabout)	65	69	Yes (>30)
A441 / Retail Access / Middlehouse Lane (roundabout)	65	69	Yes (>30)
A441 / Redditch Ringway (signal T junction)	58	92	Yes (>30)
A441 / A4023 (roundabout)	58	62	Yes (>30)

Stage 2 Screening

6.4.6 Junctions which demonstrate development flows exceeding 30 two-way trips (shown in **Table 6.2**) have been taken through to screening Stage 2. Proposed development flows were considered in context to the 2030 Base (effective) AM and PM Peak flows. Percentage impacts associated with the introduction of the proposed development are summarised in **Table 6.3**. The proportional impact has been assessed as follows:

- **Less than 3%** - This level of increase in traffic is well within the daily fluctuation levels (accepted to by 10%) and as such can be considered as a non-material impact. Consequently, no further assessments are considered necessary at these junctions.
- **3% - 10%** - This level of increase is within the daily traffic fluctuations but may need to be considered for junction assessment subject to existing capacity/traffic levels.
- **More than 10%** - This level of increase in traffic is above the daily variation and junction assessment is required.

Table 6.3 : Stage 2 Screening – Junction Impact Summary (Percentage Impact)

Junction	Development Trips		2030 Base (Effective)		Impact (%)	
	AM	PM	AM	PM	AM	PM
Hither Green Lane / Dagnell End Road (priority T junction)	152	162	832	933	18%	17%
A441 / Dagnell End Road (signal T junction)	143	152	3077*	3172*	5%	5%
A441 / Weights Lane / Odell Street (roundabout)	65	69	2729	2705	2%	3%
A441 / Retail Access / Middlehouse Lane (roundabout)	65	69	4100	4442	2%	2%
A441 / Redditch Ringway (signal T junction)	58	62	3004*	3450*	2%	2%
A441 / A4023 (roundabout)	58	62	5320	5221	1%	1%

* Numbers shown are PCUs due to absence of alternative data. Remainder of data set is shown as total vehicles.

6.4.7 As outlined above, the development can be considered to have negligible impact at the following junctions:

- A441 / Retail Access / Middlehouse Lane (roundabout);
- A441 / Redditch Ringway (signal T junction); and
- A441 / A4023 (roundabout).

6.4.8 The A441 / Dagnell End Road (signalised T junction) and A441 / Weights Lane / Odell Street (roundabout) evidence small traffic increases in terms of volumes and the percentage increases are noted to be between 5% and 3%. The impact at these junctions have been included in the junction capacity assessments for robustness.

6.4.9 Hither Green Lane / Dagnell End Road (priority T junction) experiences the highest percentage increase in traffic flows and relative traffic numbers and has also been included in the junction capacity assessments.

6.4.10 In addition to the above, the proposed site access junction has also been subject to a detailed capacity assessment.

6.4.11 The refined study area to be capacity tested is summarised as:

- Junction 1 - Site access formed with Hither Green Lane;
- Junction 2 - Hither Green Lane / Dagnell End Road priority junction;
- Junction 3 - A441 / Dagnell End Road traffic signals; and
- Junction 4 - A441 / Odell Street/Weights Lane roundabout.

6.4.12 Junctions 1, 2 and 4 have been formally assessed using the industry standard software package, Junctions 9 (PICADY / ARCADY modules) and Junction 3 has been assessed using LINSIG software.

6.5 Junction Capacity Analysis

6.5.1 When assessing junction capacity using Junctions 9 (PICADY / ARCADY modules), it is generally accepted that a Ratio of Flow to Capacity (RFC) value of below 0.85 represents a junction that is considered to be operating satisfactorily (within practical capacity). At junctions operating at or close to zero practical reserve capacity, which equates to an RFC value of approximately 1.00 or above, small reductions in capacity may result in exponential queuing and/or delay results. Therefore, junctions operating close to or above 1.00 should be carefully reviewed to ensure that queueing and delay is not significantly impacted upon, and to ensure that the new development will not have a 'severe' or detrimental impact upon the existing highway infrastructure.

6.5.2 The modelling parameters for Junctions 2 – 4 have been taken from the Brockhill East application to provide a consistent modelling base. The parameters for Junction 1 have been measured from OS mapping.

Junction 1 – Site Access / Hither Green Lane (Priority Crossroads Junction)

6.5.3 The results of the capacity assessment undertaken at the Site Access / Hither Green Lane junction are provided in **Table 6.4**, with the full output at **Appendix G**.

Table 6.4 : Site Access / Hither Green Lane

Arm	AM Peak Hour (0800 – 0900)			PM Peak Hour (1700 – 1800)		
	Queue (Veh)	Delay (s)	RFC	Queue (Veh)	Delay (s)	RFC
2030 Base + Dev						
Hither Green Lane (N)	0	6.4	0.08	0	6.94	0.22
Unnamed Access*	0	0	0	0	0	0
Hither Green Lane (S)	0	0	0	0	0	0
Site Access	0	6.84	0.19	0	6.04	0.09

* No traffic flow data has been included for this approach.

6.5.4 The results demonstrate that the site access junction will operate with significant reserve capacity during the 2030 Base + Development scenario, with a maximum RFC of 0.22 during the PM peak hour. This denotes that the Site Access / Hither Green Lane junction will operate with sufficient reserve capacity and is therefore acceptable from a capacity perspective.

6.5.5 It should be noted that no turning flow data was available for the Unnamed Access Road to the east of the proposed site access; which is understood to serve a golf range. The model has therefore been run without traffic flows on this approach. It is not envisaged that this junction would serve a significant level of traffic, and it is considered that the peak hours for the golf range and proposed residential development would likely differ. As outlined in **Table 6.4**, there is significant reserve capacity at the junction, and therefore, it is not envisaged that the addition of any turning movements associated with the golf range operation would have a significant impact on the operation of the junction.

Junction 2 – Hither Green Lane / Dagnell End Road (Priority T Junction)

6.5.6 The results of the capacity assessment undertaken at the Hither Green Lane / Dagnell End Road junction are provided in **Table 6.5**, with the full output report at **Appendix G**.

Table 6.5 : Hither Green Lane / Dagnell End Road

Arm	AM Peak Hour (0800 – 0900)			PM Peak Hour (1700 – 1800)		
	Queue (Veh)	Delay (s)	RFC	Queue (Veh)	Delay (s)	RFC
2030 Base						
Hither Green Lane	0	4.52	0.08	0	6.06	0.21
Dagnell End Road	0	7.5	0.14	0	8.22	0.13
2030 Base + Dev						
Hither Green Lane	0	4.73	0.17	1	8.65	0.44
Dagnell End Road	1	10.01	0.35	0	9.5	0.24

6.5.7 The results demonstrate that the junction will operate with significant reserve capacity during the 2030 Base + Development scenario, with a maximum RFC of 0.44 during the PM peak hour. This denotes that the Hither Green Lane / Dagnell End Road junction is therefore acceptable from a capacity perspective.

Junction 3 - A441 / Dagnell End Road (Signalised T Junction)

6.5.8 As outlined in **Section 3.4**, the Brockhill East Phase 3 scheme includes mitigation works to be implemented at the Dagnell End Road / Birmingham Road signalised junction. The mitigation scheme is outlined in PJA drawing 2809-P-12-P4, attached as **Appendix B** for reference.

6.5.9 The scheme has been designed on topographical survey data and has been deemed acceptable by WCC for the purpose of granting planning permission. The approved mitigation scheme has therefore been considered as the baseline position for the purpose of the detailed capacity assessment.

6.5.10 As set out in technical notes ‘Dagnell End Road – Junction Design Note’ (16/09/2020) and ‘Dagnell End Road – Junction Design Modelling Update’ (24/11/2020) submitted as part of the Brockhill East application (ref: 19/00976/HYB), peak hour pedestrian crossing demand at the new signalised crossing was forecast to be low, and it was anticipated that the crossing would therefore be called infrequently.

6.5.11 In addition to the above, WCC raised concerns over the incorporation of the left turn filter arrow from Dagnell End Road, as a pedestrian wishing to cross over the A441 southbound may see a stationary vehicle in the offside lane of Dagnell End Road (controlled by Phase D), without seeing the filter arrow for Phase E.

6.5.12 WCC noted that this arrangement is provided other junctions elsewhere, and that concerns were not raised in the RSA. WCC therefore suggested that a further stage sequence, excluding the left turn filter, should be included in the modelling. The matter would then be resolved at detailed design stage, or following installation of the junction based on site observations.

6.5.13 In light of the above, the modelling submitted as part of the application for Brockhill East included 3 stage sequences. A summary of the stage sequences is provided below, along with reference to a stage sequence diagram for each, which are included as **Appendix H**.

- Staging Sequence 1 – Pedestrian Crossing Not Called (**Figure 6.1**)
- Staging Sequence 2 – Pedestrian Crossing Not Called, No Filter Arrow (**Figure 6.2**)
- Staging Sequence 3 – Pedestrian Crossing Called Every Cycle (Sensitivity Test) (**Figure 6.3**)

6.5.14 The A441 / Dagnell End Road junction has therefore been modelled with consideration of each of the 3 Stage Sequences. This has been undertaken using the LinSig industry standard modelling package. A summary of the results is shown in **Table 6.6**, with the full output report attached at **Appendix G**.

Table 6.6 : A441 / Dagnell End Road – Committed Mitigation Scheme

Arm	AM Peak Hour (0800 – 0900)			PM Peak Hour (1700 – 1800)		
	DoS (%)	MMQ (PCU)	Delay / PCU (s)	DoS (%)	MMQ (PCU)	Delay / PCU (s)
2030 Base (Stage Sequence 1 – No Peds)						
A441 (N)	90.7%	28	23	88%	32	27
Dagnell End Road	99.6%	9	71	111.7%	54	277
A441 (South)	98.5%	45	51	111.1%	127	232
PRC		-10.7%			-24.1%	
2030 Base + Development (Stage Sequence 1 – No Peds)						
A441 (N)	98%	42	49	94.8%	42	41
Dagnell End Road	99.2%	17	108	114.2%	66	311
A441 (South)	103.4%	73	107	116.2%	159	309
PRC		-14.9%			-29.1%	
2030 Base (Stage Sequence 2 – No Peds & No Left Filter)						
A441 (N)	92%	29	26	88%	32	27
Dagnell End Road	100.8%	13	105	111.7%	54	280

A441 (South)	99.8%	51	62	111.1%	127	233
PRC		-12%			-24.1%	
2030 Base + Development (Stage Sequence 2 – No Peds & No Left Filter)						
A441 (N)	104.7%	73	128	94.8%	42	41
Dagnell End Road	97.7%	13	83	114.2%	66	314
A441 (South)	104.9%	81	128	116.2%	159	309
PRC		-16.5%			-29.1%	
2030 Base (Stage Sequence 3 – Peds & Left Filter)						
A441 (N)	106.6%	82	157	98.%	50	65
Dagnell End Road	100.8%	13	105	111.7%	55	281
A441 (South)	99.8%	51	61	111.1%	127	232
PRC		-18.4%			-24.1%	
2030 Base + Development (Stage Sequence 3 – Peds & Left Filter)						
A441 (N)	112.3%	113	244	106.5%	89	168
Dagnell End Road	105.2%	22	150	114.2%	66	315
A441 (South)	103.4%	73	106	116.2%	159	308
PRC		-24.7%			-29.1%	

6.5.15 The results show that the junction is predicted to operate above its theoretical capacity in 2030 Base, prior to the additional traffic associated with the proposed development. The addition of development traffic would give rise to a further deterioration in junction performance, with slight increases in queueing and delays observed at the junction. It should be noted in this respect that LinSig results which exceed DoS of 100% often generate queue lengths that are subject to exponential growth. For this reason, consideration should be made that queue lengths on over-capacity approach arms may be indicative rather than representative of actual observed conditions.

6.5.16 As outlined above, the addition of traffic associated with the proposed development does not typically result in a significant increase in the DoS recorded on the respective approaches at the junction. For example in the sensitivity scenario, during the AM peak, the increase in the DoS resulting from the development traffic ranges from 3.6% to 5.7% across the respective approaches. During the PM peak, the increase in the DoS is slightly greater; ranging from 2.5% to 13%. The greatest impacts are forecast to occur on the A441 (N) approach.

- 6.5.17 The mitigation scheme at the junction Dagnell End Road / Birmingham Road is to be delivered as part of the Brockhill East Phase 3 scheme. This scheme was previously identified in the live Redditch District Infrastructure Delivery Plan (IDP) (CDR51). As outlined in WCC's formal response to the Brockhill East Phase 3 (ref: 19/00976/HYB), this scheme has been considered acceptable in what is considered a "*constrained location in terms of land ownership*" and is to be delivered by the applicant as part of a S278 agreement.
- 6.5.18 Furthermore, it should be noted that the trip generation associated with the development include trip rates taken from the donor site at Brockhill East Phase 1, which are far greater than those obtained from the TRICS database. The junction capacity assessment also utilises 100% of development trip generation, and does not take account of any measures to reduce the traffic impact of the scheme, as set out in the accompanying Travel Plan.
- 6.5.19 It should also be acknowledged that the proposed scheme is forecast to generate approximately 152 additional two-way trips during the AM peak and 162 two-way trips during the PM peak. This equates to a c. 5% increase in development trips through this junction, when considered in context to the 2030 (effective base) background traffic figures of 3,077 two-way trips during the AM peak and 3,172 two-way trips during the PM peak. As outlined in the Stage Screening approach included in **Section 6.4**, it is envisaged that this minor percentage increase would likely be accounted for within daily fluctuations in background traffic.
- 6.5.20 In light of the above, it is considered that the proposed scheme will have a relatively minor impact at the junction, which is already predicted to operate beyond its theoretical capacity in 2030, prior to the onset of additional traffic associated with the proposed development.
- 6.5.21 It is not therefore considered that the proposed development should be liable for further mitigation, given that the junction is already predicted to operate beyond its theoretical capacity in the 2030 base. Any further mitigation is unlikely to be achievable under a S278 agreement given widening of Dagnell End Road requires land beyond the extent of the highway boundary.
- 6.5.22 It is therefore suggested that ongoing dialogue is undertaken with WCC with respect to a developer contribution to the existing mitigation scheme via a S106 agreement. An alternative suggested approach would be to direct this S106 contribution towards reducing the traffic impact at the junction through the implementation of measures to promote sustainable travel to and from the site, as set out in the corresponding Travel Plan.

Junction 4 – A441 / Odell Street / Weights Lane (Roundabout)

6.5.23 The results of the capacity assessment undertaken at the A441 / Odell Street / Weights Lane roundabout are provided in **Table 6.7**, with the full output report at **Appendix G**. The junction has been assessed using lane sim in line with the previous methodology that supported the Brockhill East Phase 4 application.

Table 6.7 A441/ Odell Street / Weights Lane Roundabout

Arm	AM Peak Hour (0800 – 0900)			PM Peak Hour (1700 – 1800)		
	Queue (Veh)	Delay (s)	RFC	Queue (Veh)	Delay (s)	RFC
2030 Base						
A441 (N)	3	7.91	0.74	3	6.81	0.71
A441 (S)	2	5.6	0.65	2	6.71	0.71
Odell Street	0	9.88	0.16	0	13.92	0.27
Weights Lane	1	6.54	0.44	0	5.10	0.26
2030 Base + Dev						
A441 (N)	3	8.91	0.77	3	7.16	0.73
A441 (S)	2	5.75	0.66	3	7.40	0.74
Odell Street	0	10.09	0.16	0	15.15	0.29
Weights Lane	1	6.66	0.44	0	5.3	0.27

6.5.24 The results demonstrate that the roundabout junction will operate with sufficient reserve capacity during the 2030 Base + Development scenario, with a maximum RFC of 0.77 during the AM peak hour. This denotes that the A441 (Birmingham Road) / Odell Street / Weights Lane Roundabout is therefore acceptable from a capacity perspective.

7. Summary & Conclusion

7.1 Summary

- 7.1.1 mode transport planning (mode) has been appointed by Barratt David Wilson Homes (Mercia) to provide highways and transport advice in relation to the submission of an outline planning application for 216 residential dwellings on land adjacent to Hither Green Lane in Redditch, Worcestershire.
- 7.1.2 The level of accessibility to the site is considered to be good with a range of opportunities for sustainable travel, by walking, cycling, or utilising the existing public transport provision. A separate RTP has been submitted as part of the planning application in order to encourage the uptake of sustainable modes of transport by future occupiers.
- 7.1.3 Analysis of the local highway network in the vicinity of the site has demonstrated that there are not any inherent highway safety issues on the local highway network surrounding the site which would likely be exacerbated by the development.
- 7.1.4 Vehicular access will be provided via a new priority crossroads junction along the site's eastern frontage, formed with Hither Green Lane and the unnamed access road serving the golf range on the opposite side of the road. The proposed access will provide a 5.5m wide carriageway with 10m corner radii and 2m wide footways on both sides of the carriageway. Pedestrian access at the junction will be supported by the provision of an uncontrolled crossing facility, in the form of dropped kerbs/ tactile paving. Appropriate visibility splays have been provided at the site access in accordance MfS and the posted speed limit of 30mph. Further to this, an emergency access has also been provided on to Dagnell End Road at the western end of the site frontage, and take the form of a 3.7m wide shared emergency / pedestrian link, with retractable bollards to prevent private vehicle access.
- 7.1.5 A tracking assessment has also been undertaken for the site access, which demonstrates that a Mercedes Econic refuse vehicle (11.7m) and Fire Tender (8.6m) can access and egress the site.
- 7.1.6 In order to encourage travel to and from the site by sustainable modes of transport, the proposed development will include a new pedestrian route between the site and Dagnell End Road. To the north of the site, a pedestrian route will link the site with Dagnell End Road. new section of footway will also be provided on the southern side of Dagnell End Road, within the existing highway boundary.

- 7.1.7 The new footway along Dagnell End Road to be delivered as part of the proposed development will connect with the footway improvements linked to the committed Brockhill East Phase 3 scheme. This will be subject to confirmation of land ownership and discussions with WCC in order to agree an appropriate mechanism to tie this into the footway improvements along Dagnell End Road.
- 7.1.8 To the south and west pedestrian / cycle connections will be provided with the existing NMU connection which runs alongside the River Arrow and connects with Birmingham Road immediately north of the river over-bridge. This will provide a direct and attractive route to the local facilities and amenities in the vicinity of the site.
- 7.1.9 In order to provide an indication of the traffic impact of the proposed scheme, trip rates have been taken from the committed development of Brockhill East Phase 1. Taking into account the trip rates from the committed development, the proposed scheme is forecast to generate approximately 152 additional two-way trips during the AM peak and 162 two-way trips during the PM peak; which equates to approximately 3 additional trips per minute on the local highway network during the respective peak hours.
- 7.1.10 In order to determine which junctions within the study area should be included for detailed assessment along the A441 corridor, mode has carried out a two stage 'screening' approach. Stage 1 identifies junctions where the two-way peak hour trip impact is greater than 30, whereas Stage 2 considers the relative increase in overall traffic when compared against the baseline; junctions where an increase of more than 3% have been recorded have been included for assessment. Through utilisation of this methodology, the following junctions have been selected for detailed capacity assessment.
- Junction 1 - Site access formed with Hither Green Lane;
 - Junction 2 - Hither Green Lane / Dagnell End Road priority junction;
 - Junction 3 - A441 / Dagnell End Road traffic signals; and
 - Junction 4 - A441 / Odell Street/Weights Lane roundabout.
- 7.1.11 The capacity assessment results for the new site access formed with Hither Green Lane demonstrate that this will operate with significant reserve capacity, with a maximum RFC of 0.22 during the PM peak hour.
- 7.1.12 The capacity assessments for the Hither Green Lane / Dagnell End Road priority junction and A441 / Odell Street/Weights Lane roundabout demonstrate that both junctions will continue to operate satisfactorily, prior to the onset of additional traffic associated with the proposed development.

- 7.1.13 The capacity assessment for the A441 / Dagnell End Road traffic signals incorporates the mitigation scheme to be delivered as part of the Brockhill East Phase 3 scheme; which was previously identified in the live Redditch District Infrastructure Delivery Plan (IDP) (CDR51). The results show that the junction is predicted to operate above its theoretical capacity in 2030 Base, prior to the additional traffic associated with the proposed development at Hither Green Lane. As outlined in WCC's formal response to the Brockhill East Phase 3 (ref: 19/00976/HYB), this scheme has been considered acceptable in what is considered a "*constrained location in terms of land ownership*" and the mitigation is to be delivered by the applicant as part of a S278 agreement.
- 7.1.14 The addition of traffic associated with the proposed development does not typically result in a significant increase in the DoS recorded on the respective approaches at the junction. The proposed development at Hither Green Lane is only forecast to have a c. 5% increase in development trips through this junction, when considered in context to the 2030 (effective base) background traffic; this level of increase could feasibly be accounted for within daily fluctuations in background traffic. It should also be noted that the capacity assessments do not take into account of any measures to reduce the traffic impact of the scheme, as set out in the accompanying Travel Plan
- 7.1.15 It is not therefore considered that the proposed development should be liable for further mitigation, given that the junction is already predicted to operate beyond its theoretical capacity in the 2030 base. It is therefore suggested that ongoing dialogue is undertaken with WCC with respect to a developer contribution to the existing mitigation scheme via a S106 agreement. An alternative suggested approach would be to direct this S106 contribution towards reducing the traffic impact at the junction through the implementation of measures to promote sustainable travel to and from the site, as set out in the corresponding Travel Plan.

7.2 Conclusion

- 7.2.1 In conclusion it is considered the proposals would deliver a development which would be accessible by a variety of modes of travel. The junction capacity assessments carried out demonstrate that the local highway network is forecast to operate within acceptable capacity parameters following the introduction of the development proposals.
- 7.2.2 Based upon the findings of this TS, it is demonstrated that the proposed development will not have a severe impact on the surrounding highway network in terms of capacity and safety, and accordingly can be considered acceptable in terms of transport and highways.

APPENDICES

APPENDIX A

Illustrative Masterplan

Summary of Accommodation	ME-24-218	ME-24-218
Proposed	No. Units	Total No.
Private (1-2 Bed)	4	4
Private (3-4 Bed)	8	8
Private (5-6 Bed)	4	4
Private (7-8 Bed)	4	4
Private (9-10 Bed)	4	4
Private (11-12 Bed)	4	4
Private (13-14 Bed)	4	4
Private (15-16 Bed)	4	4
Private (17-18 Bed)	4	4
Private (19-20 Bed)	4	4
Private (21-22 Bed)	4	4
Private (23-24 Bed)	4	4
Private (25-26 Bed)	4	4
Private (27-28 Bed)	4	4
Private (29-30 Bed)	4	4
Private (31-32 Bed)	4	4
Private (33-34 Bed)	4	4
Private (35-36 Bed)	4	4
Private (37-38 Bed)	4	4
Private (39-40 Bed)	4	4
Private (41-42 Bed)	4	4
Private (43-44 Bed)	4	4
Private (45-46 Bed)	4	4
Private (47-48 Bed)	4	4
Private (49-50 Bed)	4	4
Private (51-52 Bed)	4	4
Private (53-54 Bed)	4	4
Private (55-56 Bed)	4	4
Private (57-58 Bed)	4	4
Private (59-60 Bed)	4	4
Private (61-62 Bed)	4	4
Private (63-64 Bed)	4	4
Private (65-66 Bed)	4	4
Private (67-68 Bed)	4	4
Private (69-70 Bed)	4	4
Private (71-72 Bed)	4	4
Private (73-74 Bed)	4	4
Private (75-76 Bed)	4	4
Private (77-78 Bed)	4	4
Private (79-80 Bed)	4	4
Private (81-82 Bed)	4	4
Private (83-84 Bed)	4	4
Private (85-86 Bed)	4	4
Private (87-88 Bed)	4	4
Private (89-90 Bed)	4	4
Private (91-92 Bed)	4	4
Private (93-94 Bed)	4	4
Private (95-96 Bed)	4	4
Private (97-98 Bed)	4	4
Private (99-100 Bed)	4	4
Private (101-102 Bed)	4	4
Private (103-104 Bed)	4	4
Private (105-106 Bed)	4	4
Private (107-108 Bed)	4	4
Private (109-110 Bed)	4	4
Private (111-112 Bed)	4	4
Private (113-114 Bed)	4	4
Private (115-116 Bed)	4	4
Private (117-118 Bed)	4	4
Private (119-120 Bed)	4	4
Private (121-122 Bed)	4	4
Private (123-124 Bed)	4	4
Private (125-126 Bed)	4	4
Private (127-128 Bed)	4	4
Private (129-130 Bed)	4	4
Private (131-132 Bed)	4	4
Private (133-134 Bed)	4	4
Private (135-136 Bed)	4	4
Private (137-138 Bed)	4	4
Private (139-140 Bed)	4	4
Private (141-142 Bed)	4	4
Private (143-144 Bed)	4	4
Private (145-146 Bed)	4	4
Private (147-148 Bed)	4	4
Private (149-150 Bed)	4	4
Private (151-152 Bed)	4	4
Private (153-154 Bed)	4	4
Private (155-156 Bed)	4	4
Private (157-158 Bed)	4	4
Private (159-160 Bed)	4	4
Private (161-162 Bed)	4	4
Private (163-164 Bed)	4	4
Private (165-166 Bed)	4	4
Private (167-168 Bed)	4	4
Private (169-170 Bed)	4	4
Private (171-172 Bed)	4	4
Private (173-174 Bed)	4	4
Private (175-176 Bed)	4	4
Private (177-178 Bed)	4	4
Private (179-180 Bed)	4	4
Private (181-182 Bed)	4	4
Private (183-184 Bed)	4	4
Private (185-186 Bed)	4	4
Private (187-188 Bed)	4	4
Private (189-190 Bed)	4	4
Private (191-192 Bed)	4	4
Private (193-194 Bed)	4	4
Private (195-196 Bed)	4	4
Private (197-198 Bed)	4	4
Private (199-200 Bed)	4	4
Private (201-202 Bed)	4	4
Private (203-204 Bed)	4	4
Private (205-206 Bed)	4	4
Private (207-208 Bed)	4	4
Private (209-210 Bed)	4	4
Private (211-212 Bed)	4	4
Private (213-214 Bed)	4	4
Private (215-216 Bed)	4	4
Private (217-218 Bed)	4	4
Private (219-220 Bed)	4	4
Private (221-222 Bed)	4	4
Private (223-224 Bed)	4	4
Private (225-226 Bed)	4	4
Private (227-228 Bed)	4	4
Private (229-230 Bed)	4	4
Private (231-232 Bed)	4	4
Private (233-234 Bed)	4	4
Private (235-236 Bed)	4	4
Private (237-238 Bed)	4	4
Private (239-240 Bed)	4	4
Private (241-242 Bed)	4	4
Private (243-244 Bed)	4	4
Private (245-246 Bed)	4	4
Private (247-248 Bed)	4	4
Private (249-250 Bed)	4	4
Private (251-252 Bed)	4	4
Private (253-254 Bed)	4	4
Private (255-256 Bed)	4	4
Private (257-258 Bed)	4	4
Private (259-260 Bed)	4	4
Private (261-262 Bed)	4	4
Private (263-264 Bed)	4	4
Private (265-266 Bed)	4	4
Private (267-268 Bed)	4	4
Private (269-270 Bed)	4	4
Private (271-272 Bed)	4	4
Private (273-274 Bed)	4	4
Private (275-276 Bed)	4	4
Private (277-278 Bed)	4	4
Private (279-280 Bed)	4	4
Private (281-282 Bed)	4	4
Private (283-284 Bed)	4	4
Private (285-286 Bed)	4	4
Private (287-288 Bed)	4	4
Private (289-290 Bed)	4	4
Private (291-292 Bed)	4	4
Private (293-294 Bed)	4	4
Private (295-296 Bed)	4	4
Private (297-298 Bed)	4	4
Private (299-300 Bed)	4	4
Private (301-302 Bed)	4	4
Private (303-304 Bed)	4	4
Private (305-306 Bed)	4	4
Private (307-308 Bed)	4	4
Private (309-310 Bed)	4	4
Private (311-312 Bed)	4	4
Private (313-314 Bed)	4	4
Private (315-316 Bed)	4	4
Private (317-318 Bed)	4	4
Private (319-320 Bed)	4	4
Private (321-322 Bed)	4	4
Private (323-324 Bed)	4	4
Private (325-326 Bed)	4	4
Private (327-328 Bed)	4	4
Private (329-330 Bed)	4	4
Private (331-332 Bed)	4	4
Private (333-334 Bed)	4	4
Private (335-336 Bed)	4	4
Private (337-338 Bed)	4	4
Private (339-340 Bed)	4	4
Private (341-342 Bed)	4	4
Private (343-344 Bed)	4	4
Private (345-346 Bed)	4	4
Private (347-348 Bed)	4	4
Private (349-350 Bed)	4	4
Private (351-352 Bed)	4	4
Private (353-354 Bed)	4	4
Private (355-356 Bed)	4	4
Private (357-358 Bed)	4	4
Private (359-360 Bed)	4	4
Private (361-362 Bed)	4	4
Private (363-364 Bed)	4	4
Private (365-366 Bed)	4	4
Private (367-368 Bed)	4	4
Private (369-370 Bed)	4	4
Private (371-372 Bed)	4	4
Private (373-374 Bed)	4	4
Private (375-376 Bed)	4	4
Private (377-378 Bed)	4	4
Private (379-380 Bed)	4	4
Private (381-382 Bed)	4	4
Private (383-384 Bed)	4	4
Private (385-386 Bed)	4	4
Private (387-388 Bed)	4	4
Private (389-390 Bed)	4	4
Private (391-392 Bed)	4	4
Private (393-394 Bed)	4	4
Private (395-396 Bed)	4	4
Private (397-398 Bed)	4	4
Private (399-400 Bed)	4	4
Private (401-402 Bed)	4	4
Private (403-404 Bed)	4	4
Private (405-406 Bed)	4	4
Private (407-408 Bed)	4	4
Private (409-410 Bed)	4	4
Private (411-412 Bed)	4	4
Private (413-414 Bed)	4	4
Private (415-416 Bed)	4	4
Private (417-418 Bed)	4	4
Private (419-420 Bed)	4	4
Private (421-422 Bed)	4	4
Private (423-424 Bed)	4	4
Private (425-426 Bed)	4	4
Private (427-428 Bed)	4	4
Private (429-430 Bed)	4	4
Private (431-432 Bed)	4	4
Private (433-434 Bed)	4	4
Private (435-436 Bed)	4	4
Private (437-438 Bed)	4	4
Private (439-440 Bed)	4	4
Private (441-442 Bed)	4	4
Private (443-444 Bed)	4	4
Private (445-446 Bed)	4	4
Private (447-448 Bed)	4	4
Private (449-450 Bed)	4	4
Private (451-452 Bed)	4	4
Private (453-454 Bed)	4	4
Private (455-456 Bed)	4	4
Private (457-458 Bed)	4	4
Private (459-460 Bed)	4	4
Private (461-462 Bed)	4	4
Private (463-464 Bed)	4	4
Private (465-466 Bed)	4	4
Private (467-468 Bed)	4	4
Private (469-470 Bed)	4	4
Private (471-472 Bed)	4	4
Private (473-474 Bed)	4	4
Private (475-476 Bed)	4	4
Private (477-478 Bed)	4	4
Private (479-480 Bed)	4	4
Private (481-482 Bed)	4	4
Private (483-484 Bed)	4	4
Private (485-486 Bed)	4	4
Private (487-488 Bed)	4	4
Private (489-490 Bed)	4	4
Private (491-492 Bed)	4	4
Private (493-494 Bed)	4	4
Private (495-496 Bed)	4	4
Private (497-498 Bed)	4	4
Private (499-500 Bed)	4	4
Private (501-502 Bed)	4	4
Private (503-504 Bed)	4	4
Private (505-506 Bed)	4	4
Private (507-508 Bed)	4	4
Private (509-510 Bed)	4	4
Private (511-512 Bed)	4	4
Private (513-514 Bed)	4	4
Private (515-516 Bed)	4	4
Private (517-518 Bed)	4	4
Private (519-520 Bed)	4	4
Private (521-522 Bed)	4	4
Private (523-524 Bed)	4	4
Private (525-526 Bed)	4	4
Private (527-528 Bed)	4	4
Private (529-530 Bed)	4	4
Private (531-532 Bed)	4	4
Private (533-534 Bed)	4	4
Private (535-536 Bed)	4	4
Private (537-538 Bed)	4	4
Private (539-540 Bed)	4	4
Private (541-542 Bed)	4	4
Private (543-544 Bed)	4	4
Private (545-546 Bed)	4	4
Private (547-548 Bed)	4	4
Private (549-550 Bed)	4	4
Private (551-552 Bed)	4	4
Private (553-554 Bed)	4	4
Private (555-556 Bed)	4	4
Private (557-558 Bed)	4	4
Private (559-560 Bed)	4	4
Private (561-562 Bed)	4	4
Private (563-564 Bed)	4	4
Private (565-566 Bed)	4	4
Private (567-568 Bed)	4	4
Private (569-570 Bed)	4	4
Private (571-572 Bed)	4	4
Private (573-574 Bed)	4	4
Private (575-576 Bed)	4	4
Private (577-578 Bed)	4	4
Private (579-580 Bed)	4	4
Private (581-582 Bed)	4	4
Private (583-584 Bed)	4	4
Private (585-586 Bed)	4	4
Private (587-588 Bed)	4	4
Private (589-590 Bed)	4	4
Private (591-592 Bed)	4	4
Private (593-594 Bed)	4	4
Private (595-596 Bed)	4	4
Private (597-598 Bed)	4	4
Private (599-600 Bed)	4	4
Private (601-602 Bed)	4	4
Private (603-604 Bed)	4	4
Private (605-606 Bed)	4	4
Private (607-608 Bed)	4	4
Private (609-610 Bed)	4	4
Private (611-612 Bed)	4	4
Private (613-614 Bed)	4	4
Private (615-616 Bed)	4	4
Private (617-618 Bed)	4	4
Private (619-620 Bed)	4	4
Private (621-622 Bed)	4	4
Private (623-624 Bed)	4	4
Private (625-626 Bed)	4	4
Private (627-628 Bed)	4	4
Private (629-630 Bed)	4	4
Private (631-632 Bed)	4	4
Private (633-634 Bed)	4	4
Private (635-636 Bed)	4	4
Private (637-638 Bed)	4	4
Private (639-640 Bed)	4	4
Private (641-642 Bed)	4	4
Private (643-644 Bed)	4	4
Private (645-646 Bed)	4	4
Private (647-648 Bed)	4	4
Private (649-650 Bed)	4	4
Private (651-652 Bed)	4	4
Private (653-654 Bed)	4	4
Private (655-656 Bed)	4	4
Private (657-658 Bed)		

APPENDIX B

Committed Highways Mitigation Scheme

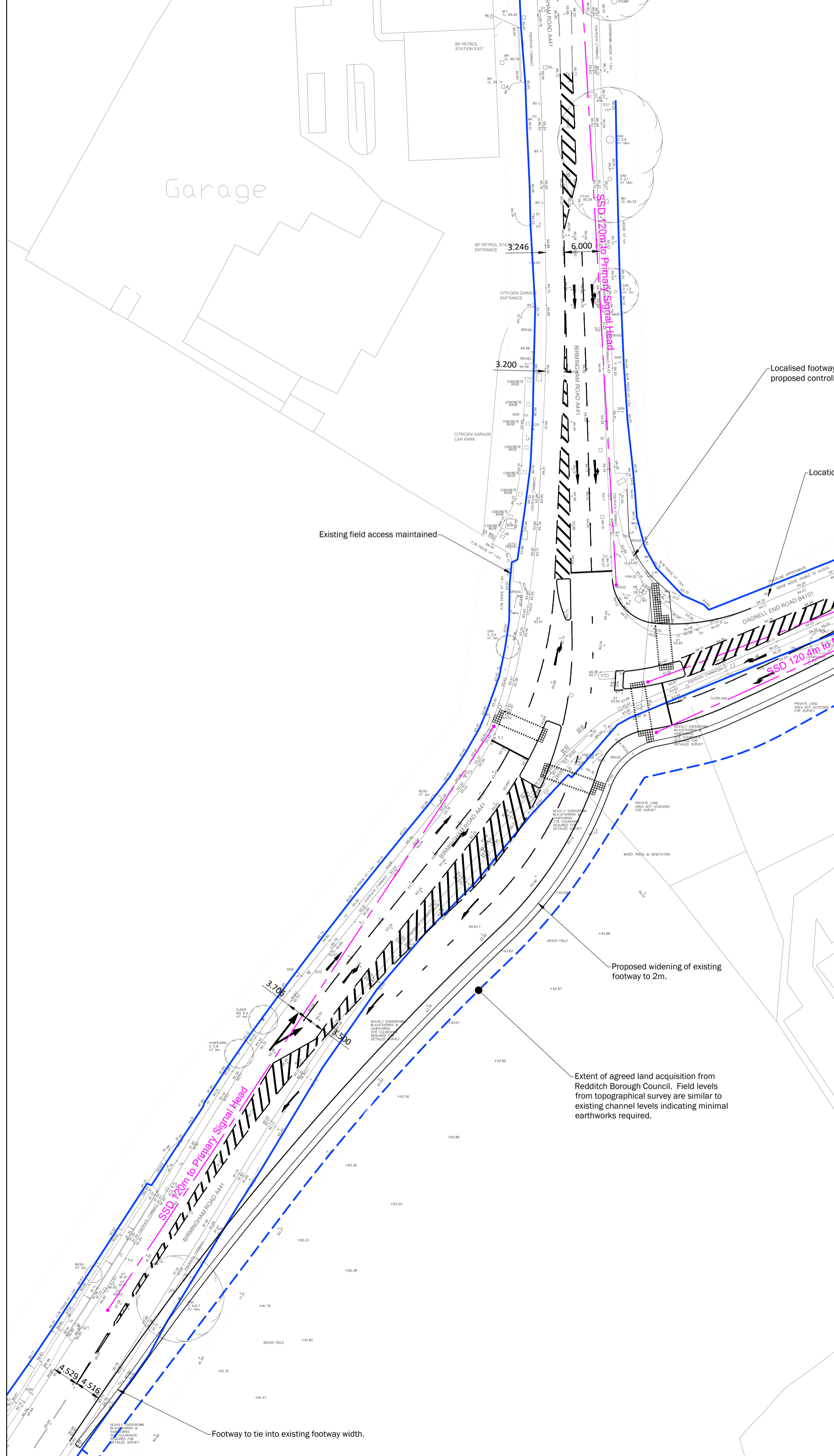
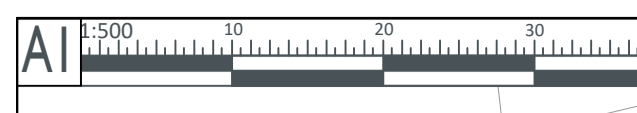

Junction Overview

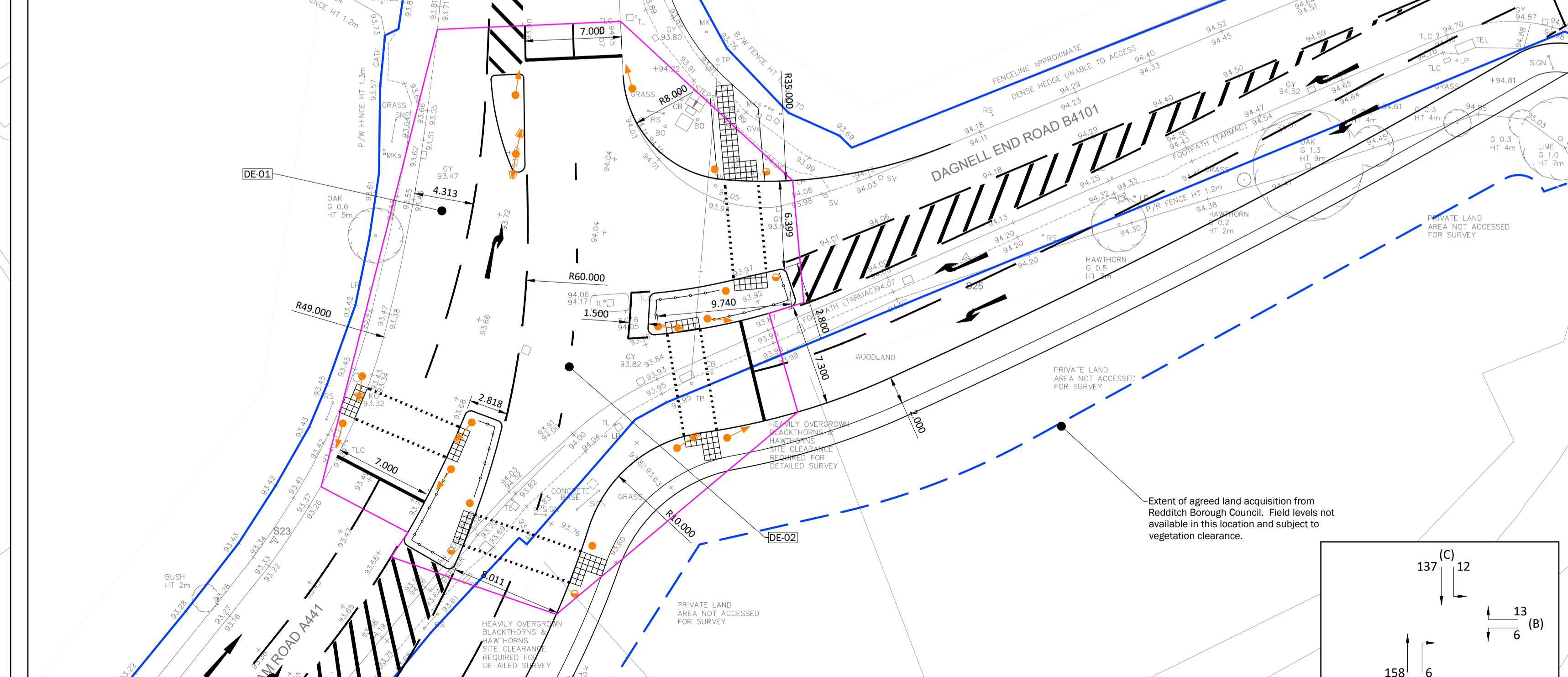
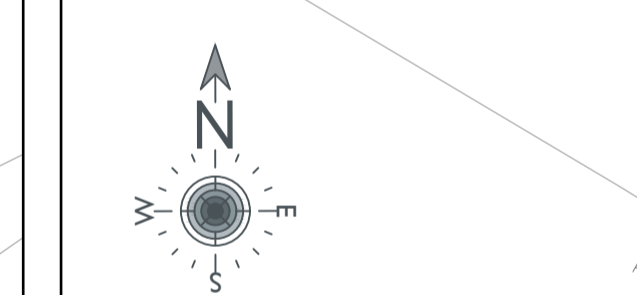
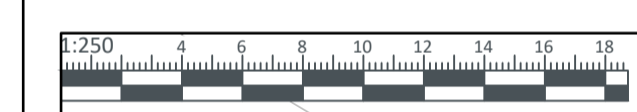

Junction Detail

Departures from Standard

DE-01: Lane Widths

- Standard: DMRB CD123 (5.10)
- Requirement: Inside Lane width 4.4m (50m R)
- Achieved: Inside Lane width 3.5-4.3m (Varies)

DE-02: Lane Widths

- Standard: DMRB CD123 (5.10)
- Requirement: Inside Lane width 4.15m (60m R, Interpreted from Table 5.10)
- Outside Lane Width 4.10 (60m R, Interpreted from Table 5.10)
- Achieved: Inside Lane width 4.0m, Outside Lane width 4.0m.

These drawings have been produced with reference to the CDM Regulations 2015. Please note that these are pre-construction phase drawings and should be subject to further design risk management as required in accordance with Regulation 9

Notes

- Do not scale from this drawing.
- All dimensions in metres unless stated otherwise.
- The purpose of this drawing is to demonstrate the ability to deliver a junction improvement scheme at Dagnell End Road in support of an associated residential planning application.
- This drawing should be read in conjunction with all other project related drawings.
- Drawing is based on Topographical survey (ref:27285_R2) and is limited to a 2D design at this stage.
- OS Mapping is included for context.
- Highway Boundary information has been reproduced and interpreted from data received from Worcestershire County Council ref 90067 dated 20/07/20.
- For Private Land Boundary details refer to drawing 2809-P-014.
- All boundaries have been reproduced from source data, however there are limited features in which to interpret this information against and as such all boundaries should be verified on site.
- Design has been based on the principles of DMRB CD123, Design of Signalised Junctions and Traffic Signs Manual Chapter 6.
- Visibility to the primary signal heads on Birmingham Road have been based on a 70kph design speed to reflect the existing 40mph speed limit.
- Visibility to the primary signal heads on Dagnell End Road have been based on 85th Percentile speed data undertaken on 18th November 2020 and adjusted to reflect an 85th percentile speed of 44mph and visibility of 120.4m.
- Curve widening has been applied through the junction to reflect the internal bend radii being less than 90m. Full widening has not been achievable and as such these have been highlighted as Departures from CD123.
- Vehicle Tracking has been undertaken using the "Design Vehicle" as specified by DMRB CD123. Tracking adjacent to refuge islands has sought to achieve a 500mm clearance between the design vehicle and kerblines where possible as required by Worcestershire County Council. Reference should be made to the predicted daily HGV movements for context.
- Traffic signal equipment shown on the drawing is indicative and subject to detailed design.
- The design has been updated in line with highway authority comments and incorporating controlled pedestrian facilities.
- The design is subject to transport modeling and an updated stage 1 Road Safety Audit.

Key

	Highway Boundary
	Land Acquisition Boundary
	Proposed Channel/Kerblines
	Proposed Back of Footway
	Proposed back of verge
	Forward visibility to Primary signal head
	Junction Inter visibility Zone
	Proposed Red Tactile Paving
	Proposed Primary Signal Head
	Proposed Secondary Signal Head

REV	DATE	REVISION NOTE	BY
P4	23.11.20	Dagnell End Rd island amended, hatching & Keep clear added	SG
P3	19.11.20	Finalised to topographical survey following meeting with WCC (16/11/20)	SG
P2	12.11.20	Updated layout for Topographical Survey incorporating WCC comments	GH
P1	07.08.20	Widening, staggered crossing WCC comments incorporated	GH
P0	01.12.19	Initial Design	JL

PJA Seven House - High Street
Longbridge - Birmingham
B31 2LQ - Tel: 0121 475 0234

Birmingham - Bristol
Exeter - London - Reading
pja.co.uk

CLIENT: Persimmon Homes South Midlands

PROJECT: Brockhill East
Dagnell End Road
Junction

DRAWING TITLE: Proposed Signalised
Junction Improvements

DRAWING ISSUE STATUS

PLANNING

PJA JOB No. SUB-CODE DRAWING NO. REVISION

2809 - P - 12 - P4

Revision Letters: P - Prelim / A - Approval / T - Tender / C - Construction
BIM DRAWING REFERENCE:

SCALE	DRAWN	REVIEWED	DATE
A1@1:500	GH	SG	12.2019

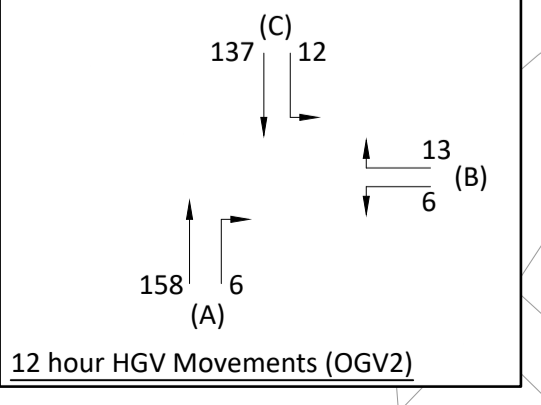

APPENDIX C

Collision Data

Accidents between dates **01/07/2016** and **30/06/2021** (60) months

Selection: **Redditch.**

Notes: Josh Norris 13.08.2021

Police Ref.	Date	Cas.	Sev.	P2W	Cycs	Peds	Ch	OAPs	Vis.	Manv.	Road Cond.	Time	Location
1698283	09/08/2016	1	Slight	1	0	0	0	0	Light	No turn	Dry	1913	ALVECHURCH HIGHWAY REDDITCH A441 MIDDLEHOUSE LA B4184
16105563	31/08/2016	1	Serious	0	0	0	0	0	Dark	No turn	Dry	2245	ALVECHURCH HIGHWAY REDDITCH A441 COVENTRY HIGHWAY
16107993	09/09/2016	1	Slight	0	0	0	0	0	Light	No turn	Dry	0810	ALVECHURCH HIGHWAY REDDITCH (SB) A441 COVENTRY
16108996	12/09/2016	2	Slight	0	0	0	0	0	Light	No turn	Dry	1745	BIRMINGHAM ROAD BORDESLEY A441 AT J/W REDDITCH RD
16115283	16/09/2016	1	Slight	0	0	0	1	0	Light	No turn	Dry	1530	RIVERSIDE ISLAND ALVECHURCH HIGHWAY REDDITCH A441 B4184
16112592	22/09/2016	2	Slight	1	0	0	0	0	Dark	Right	Dry	2015	O/S NO. 445 BIRMINGHAM ROAD BORDESLEY REDDITCH A441
17164143	03/03/2017	1	Serious	0	0	0	0	0	Light	Right	Wet/Damp	1035	DAGNELL END ROAD B4104 MEADOW FARM PUB
17175747	15/04/2017	1	Slight	0	0	0	0	0	Light	Right	Dry	1125	471 BIRMINGHAM ROAD BORDESLEY REDDITCH A441 AT J/W SERVI
17188891	03/06/2017	1	Slight	0	0	0	0	0	Light	No turn	Dry	1335	ALVECHURCH HIGHWAY A441 MIDDLEHOUSE LANE B4184
17250156	12/12/2017	1	Slight	0	0	0	0	0	Light	No turn	Snow	1319	A441 AT J/W A4023
18274550	04/01/2018	4	Serious	0	0	0	0	0	Dark	Left	Wet/Damp	1800	ALVECHURCH A441 AT J/W COVENTRY HIGHWAY A4023
18286433	14/04/2018	5	Slight	0	0	0	0	2	Light	No turn	Dry	1011	BORDESLEY A441 NEAR J/W REDDITCH ROAD
18336287	15/10/2018	1	Slight	0	0	0	0	0	Light	No turn	Dry	1650	ALVECHURCH HIGHWAY A441 AT J/W MIDDLEHOUSE LANE B4184
18340341	17/10/2018	1	Serious	1	0	0	0	0	Light	No turn	Dry	1703	ALVECHURCH HIGHWAY ISLAND A441 AT J/W COVENTRY HIGHWAY
18343509	08/11/2018	1	Slight	0	0	0	0	0	Light	No turn	Dry	1015	MILLRACE ROAD
18346018	18/11/2018	1	Slight	0	1	0	0	0	Light	No turn	Dry	0927	ALVECHURCH HIGHWAY A441 AT J/W RIVERSIDE ISLAND A441
19819539	25/02/2019	2	Serious	0	0	0	0	0	Dark	No turn	Dry	1940	A441 ALVECHURCH HIGHWAY J/W B4160 REDDITCH RINGWAY
19831806	18/03/2019	3	Serious	0	0	0	0	0	Light	No turn	Dry	0812	COVENTRY HIGHWAY (A4023) WESTBOUND
19828023	19/03/2019	1	Slight	0	0	0	0	0	Light	No turn	Dry	0725	MILLRACE ROAD AT J/W BORDESLEY LANE
19843060	23/05/2019	1	Slight	0	0	0	0	0	Light	No turn	Dry	1400	ALVECHURCH HIGHWAY (A441) J/W A441 ALVECHURCH HIGHWAY
19875991	13/08/2019	2	Serious	0	0	0	0	0	Light	Right	Dry	1035	BIRMINGHAM ROAD (A441) J/W DAGNELL END ROAD (B4101)
19886858	04/10/2019	1	Slight	0	0	0	0	1	Light	No turn	Wet/Damp	1415	ALVECHURCH HIGHWAY (A441)
19907380	08/12/2019	2	Serious	0	0	0	0	1	Dark	No turn	Wet/Damp	0150	COVENTRY HIGHWAY (A4023)
20917749	06/01/2020	1	Slight	1	0	0	0	0	Light	Left	Wet/Damp	0750	BIRMINGHAM ROAD (A441)
20947639	17/03/2020	1	Serious	0	0	1	0	0	Light	No turn	Wet/Damp	1100	UNCLASSIFIED RD - 24 METRES FROM J/W ALVECHURCH HIGHWAY
20944493	29/03/2020	1	Slight	0	0	0	0	0	Dark	No turn	Dry	1930	ALVECHURCH HIGHWAY (A441) REDDITCH
20953954	22/05/2020	1	Slight	0	0	0	0	0	Light	No turn	Dry	1533	ALVECHURCH HIGHWAY (A441) OPP THE PREMIER INN REDDITCH
20964978	07/07/2020	1	Slight	0	0	0	0	0	Light	No turn	Dry	1850	ALVECHURCH HIGHWAY (A441) BIRMINGHAM ROAD REDDITCH J/W
20969663	22/07/2020	1	Slight	0	0	0	0	0	Light	Left	Dry	1550	COVENTRY HIGHWAY (A4023) SLIP RD REDDITCH J/W ALVECHURCH
20974102	11/08/2020	2	Slight	0	0	0	0	1	Light	No turn	Dry	1500	COVENTRY HIGHWAY (A4023) SLIP ROAD REDDITCH J/W ALVECHUR
20999464	08/11/2020	1	Slight	0	0	1	1	0	Light	No turn	Dry	1500	BIRMINGHAM RD (A441) BORDESLEY 182M FROM J/W DAGNELL END

Casualty Totals 46

Total number of accidents listed: 31

Accidents between dates 01/07/2016 and 30/06/2021 (60) months

Selection: Redditch.

Notes: Josh Norris 13.08.2021

1698283 09/08/2016 Time 1913 Vehicles 2 Casualties 1 Slight
E: 404351 N: 268477 First Road: A 441 Road Type Dual carriageway
Speed limit: 40 Junction Detail: Roundabout Give way or controlled
Crossing: Control None Facilities: None within 50m Road surface Dry
Daylight:street lights present Fine without high winds
Special Conditions at Site None

THE MOTORCYCLIST ATTEMPTED TO CHANGE FROM L1 TO L2 AND HAS COLLIDED WITH THE MOTORCAR CAUSING HIM TO COME OFF HIS MOTORCYCLE.

Occurred on ALVECHURCH HIGHWAY REDDITCH A441 MIDDLEHOUSE LANE B4184

Vehicle Reference 1 Car Going ahead other
Vehicle movement from S to N No tow / articulation
No skidding, jack-knifing or overturning
Location at impact Jct Approach First impact Offside Hit vehicle:
Age of Driver 54 Female

Vehicle Reference 2 Motor Cycle over 50 cc and up to 12 Changing lane to left
Vehicle movement from S to N No tow / articulation
No skidding, jack-knifing or overturning
Location at impact Jct Approach First impact Nearside Hit vehicle:
Age of Driver 20 Male

Casualty Ref: 1 Vehicle: 2 Age: 20 Male Driver/rider Severity: Slight

Accidents between dates 01/07/2016 and 30/06/2021 (60) months

Selection: Redditch.

Notes: Josh Norris 13.08.2021

16105563 31/08/2016 Time 2245 Vehicles 1 Casualties 1 Serious
E: 404878 N: 267902 First Road: A 441 Road Type Dual carriageway
Speed limit: 40 Junction Detail: Roundabout Give way or controlled
Crossing: Control None Facilities: None within 50m Road surface Dry
Darkness: street lights present and lit Fine without high winds
Special Conditions at Site None

V1 WAS TAKEN WITHOUT THE OWNERS CONSENT, CRASHED INTO THE INSIDE BARRIER BRINGING THE VEHICLE TO A STOP. V1 THEN SET ON FIRE.

Occurred on ALVECHURCH HIGHWAY REDDITCH A441 COVENTRY HIGHWAY A4023

Vehicle Reference 1 Car Going ahead other
Vehicle movement from NW to SE No tow / articulation
No skidding, jack-knifing or overturning
Location at impact Entering roundabout First impact Offside Hit vehicle:
Age of Driver 37 Male
Casualty Ref: 1 Vehicle: 1 Age: 37 Male Driver/rider Severity: Serious

Accidents between dates 01/07/2016 and 30/06/2021 (60) months

Selection: Redditch.

Notes: Josh Norris 13.08.2021

16107993 09/09/2016 Time 0810 Vehicles 2 Casualties 1 Slight
E: 404880 N: 267909 First Road: A 441 Road Type Dual carriageway
Speed limit: 40 Junction Detail: Roundabout Give way or controlled
Crossing: Control None Facilities: None within 50m Road surface Dry
Daylight:street lights present Fine without high winds
Special Conditions at Site None

V2 PARKED AT THE JUNCTION OF THE ISLAND IN THE MIDDLE LANE WHEN V1 HAS DRIVEN INTO THE REAR OF V2.

Occurred on ALVECHURCH HIGHWAY REDDITCH (SOUTHBOUND) A441 COVENTRY HIGHWAY A4023

Vehicle Reference	1	Car	Stopping		
Vehicle movement from	NW	to SE	No tow / articulation		
			No skidding, jack-knifing or overturning		
Location at impact	Jct	Approach	First impact	Front	Hit vehicle:
			Age of Driver	50	Female
Vehicle Reference	2	Car	Going ahead but held up		
Vehicle movement from	NW	to SE	No tow / articulation		
			No skidding, jack-knifing or overturning		
Location at impact	Jct	Approach	First impact	Back	Hit vehicle:
			Age of Driver	35	Male
Casualty Ref:	1	Vehicle: 2	Age: 35	Male	Driver/rider
					Severity: Slight

Accidents between dates 01/07/2016 and 30/06/2021 (60) months

Selection: Redditch.

Notes: Josh Norris 13.08.2021

16108996 12/09/2016 Time 1745 Vehicles 3 Casualties 2 Slight
 E: 403590 N: 270523 First Road: A 441 Road Type Single carriageway
 Speed limit: 40 Junction Detail: Roundabout Give way or controlled
 Crossing: Control None Facilities: None within 50m Road surface Dry
 Daylight:street lights present Fine without high winds
 Special Conditions at Site None

A VEHICLE HAD BROKEN DOWN WHICH WAS CAUSING VEHICLES TO DRIVE AROUND. V3 STOPPED IN A ROW OF CARS WAITING FOR THE ISLAND. V2 COLLIDED WITH V3 AND V1 COLLIDED WITH V2

Occurred on BIRMINGHAM ROAD BORDESLEY A441 AT J/W REDDITCH RD

Vehicle Reference	1	Car	Stopping			
Vehicle movement from	S	to N	No tow / articulation			
Location at impact	Jct Approach		No skidding, jack-knifing or overturning			
			First impact	Front		Hit vehicle:
			Age of Driver	53		Female
Casualty Ref:	1	Vehicle: 1	Age: 53	Female	Driver/rider	Severity: Slight
Vehicle Reference	2	Goods vehicle - unknown weight	Stopping			
Vehicle movement from	S	to N	No tow / articulation			
Location at impact	Jct Approach		No skidding, jack-knifing or overturning			
			First impact	Front		Hit vehicle:
			Age of Driver	51		Male
Casualty Ref:	2	Vehicle: 2	Age: 51	Male	Driver/rider	Severity: Slight
Vehicle Reference	3	Car	Going ahead but held up			
Vehicle movement from	S	to N	No tow / articulation			
Location at impact	Jct Approach		No skidding, jack-knifing or overturning			
			First impact	Back		Hit vehicle:
			Age of Driver	60		Female

Accidents between dates 01/07/2016 and 30/06/2021 (60) months

Selection: Redditch.

Notes: Josh Norris 13.08.2021

16115283 16/09/2016 Time 1530 Vehicles 2 Casualties 1 Slight
E: 404258 N: 268601 First Road: A 441 Road Type Single carriageway
Speed limit: 40 Junction Detail: Roundabout Give way or controlled
Crossing: Control None Facilities: None within 50m Road surface Dry
Daylight:street lights present Fine without high winds
Special Conditions at Site None

V1 HAS REACHED THE JUNCTION OF THE TRAFFIC ISLAND. V2 HAS FAILED TO LOOK PROPERLY AND HAS COLLIDED WITH THE REAR OF V1.

Occurred on RIVERSIDE ISLAND ALVECHURCH HIGHWAY REDDITCH A441 B4184

Vehicle Reference	1	Car	Stopping		
Vehicle movement from	NW	to SE	No tow / articulation		
Location at impact	Jct Approach		No skidding, jack-knifing or overturning		
			First impact	Back	Hit vehicle:
			Age of Driver	34	Female
Vehicle Reference	2	Car	Going ahead other		
Vehicle movement from	NW	to SE	No tow / articulation		
Location at impact	Jct Approach		No skidding, jack-knifing or overturning		
			First impact	Front	Hit vehicle:
			Age of Driver	54	Female
Casualty Ref:	1	Vehicle: 2	Age: 11	Female	Passenger
					Severity: Slight

Accidents between dates 01/07/2016 and 30/06/2021 (60) months

Selection: Redditch.

Notes: Josh Norris 13.08.2021

16112592 22/09/2016 Time 2015 Vehicles 2 Casualties 2 Slight
 E: 403724 N: 270170 First Road: A 441 Road Type Single carriageway
 Speed limit: 40 Junction Detail: Not within 20m of junction
 Crossing: Control None Facilities: None within 50m Road surface Dry
 Darkness: street lights present and lit Fine without high winds
 Special Conditions at Site None

V1 STATIONARY IN TRAFFIC ON A441,WHILST WAITING, V1 DECIDED TO PULL OUT OF THE QUEUE AND TURN RIGHT ACROSS THE MIDDLE OF THE ROAD TO TURN AROUND AND GO THE OPPOSITE WAY, HOWEVER, AS V1 HAS PULLED OUT V2 THE BIKE HAS BEEN DRIVING ALONGSIDE THE TRAFFIC TO PASS IT AND COLLIDED WITH V1.

Occurred on O/S NO. 445 BIRMINGHAM ROAD BORDESLEY REDDITCH A441

Vehicle Reference	1	Car	U-turn					
Vehicle movement from	NW	to NW	No tow / articulation					
			No skidding, jack-knifing or overturning					
Location at impact	Not at, or within 20M of Jct		First impact		Offside	Hit vehicle:		
			Age of Driver	36	Male			
Casualty Ref:	2	Vehicle: 1	Age: 33	Female	Passenger	Severity:	Slight	
Vehicle Reference	2	Motorcycle over 500cc	Overtaking stat vehicle O/S					
Vehicle movement from	NW	to SE	No tow / articulation					
			No skidding, jack-knifing or overturning					
Location at impact	Not at, or within 20M of Jct		First impact		Nearside	Hit vehicle:		
			Age of Driver	47	Male			
Casualty Ref:	1	Vehicle: 2	Age: 47	Male	Driver/rider	Severity:	Slight	

Accidents between dates 01/07/2016 and 30/06/2021 (60) months

Selection: Redditch.

Notes: Josh Norris 13.08.2021

17164143 03/03/2017 Time 1035 Vehicles 2 Casualties 1 Serious
E: 404205 N: 269482 First Road: B 4104 Road Type Single carriageway
Speed limit: 40 Junction Detail: T & Stag Jct Give way or controlled
Crossing: Control None Facilities: None within 50m Road surface Wet/Damp
Daylight:street lights present Other
Special Conditions at Site None

V1 APPEARS TO HAVE OVERTAKEN WITNESS1 VEHICLE THEN V2 LORRY TURNS RIGHT INTO PUB AND COLLIDES WITH V1

Occurred on DAGNELL END ROAD B4104 MEADOW FARM PUB

Vehicle Reference	1	Car	Overtaking moving vehicle O/S			
Vehicle movement from	SW	to E	No tow / articulation			
Location at impact	Jct Approach	No skidding, jack-knifing or overturning				
		First impact	Nearside	Hit vehicle:		
		Age of Driver	31	Hit vehicle:	Male	
Casualty Ref:	1	Vehicle: 1	Age: 31	Male	Driver/rider	Severity: Serious
Vehicle Reference	2	Goods vehicle - unknown weight	Turning right			
Vehicle movement from	E	to S	Articulated			
Location at impact	Jct Approach	No skidding, jack-knifing or overturning				
		First impact	Front	Hit vehicle:		
		Age of Driver	53	Hit vehicle:	Male	

Accidents between dates 01/07/2016 and 30/06/2021 (60) months

Selection: Redditch.

Notes: Josh Norris 13.08.2021

17175747 15/04/2017 Time 1125 Vehicles 2 Casualties 1 Slight
 E: 403626 N: 270383 First Road: A 441 Road Type Single carriageway
 Speed limit: 40 Junction Detail: Other Give way or controlled
 Crossing: Control None Facilities: None within 50m Road surface Dry
 Daylight:street lights present Fine without high winds
 Special Conditions at Site None

V1 ATTEMPTING TO PULL OFF THE SERVICE ROAD DRIVEWAY AND THE A441 BIRMINGHAM RD HEADING TOWARDS REDDITCH. V2 IS DRIVING TOWARDS V1 DRIVING ON THE A441 TOWARDS ALVECHURCH. V1 PULLS ONTO ROAD, V2 TRIES TO AVOID COLLISION BUT COLLIDES WITH V1 WHO HAS PULLED ACROSS THE PATH OF V2.

Occurred on 471 BIRMINGHAM ROAD BORDESLEY REDDITCH A441 AT J/W SERVICE ROAD DRIVEWAY

Vehicle Reference 1 Car Turning right
 Vehicle movement from W to S No tow / articulation
 No skidding, jack-knifing or overturning
 Location at impact Entering main road First impact Front Hit vehicle:
 Age of Driver 34 Female
 Casualty Ref: 1 Vehicle: 1 Age: 34 Female Driver/rider Severity: Slight

Vehicle Reference 2 Goods 7.5 tonnes mgw and over Going ahead other
 Vehicle movement from S to N No tow / articulation
 No skidding, jack-knifing or overturning
 Location at impact Mid Junction - on roundabout or First impact Front Hit vehicle:
 Age of Driver 45 Male

Accidents between dates 01/07/2016 and 30/06/2021 (60) months

Selection: Redditch.

Notes: Josh Norris 13.08.2021

17188891 03/06/2017 Time 1335 Vehicles 2 Casualties 1 Slight
E: 404259 N: 268601 First Road: A 441 Road Type 1
Speed limit: 40 Junction Detail: Roundabout Give way or controlled
Crossing: Control None Facilities: None within 50m Road surface Dry
Daylight:street lights present Fine without high winds
Special Conditions at Site None

V1 STATIONARY AT THE TRAFFIC ISLAND WAITING FOR A GAP IN THE TRAFFIC. V2 WAS BEHIND AND HAS SEEN A GAP AND MOVED FORWARD INTO THE REAR OF V1 WHICH DID NOT MOVE OFF AS ANTICIPATED.

Occurred on ALVECHURCH HIGHWAY A441 MIDDLEHOUSE LANE B4184

Vehicle Reference	1	Car	Going ahead but held up			
Vehicle movement from	NW	to SE	No tow / articulation			
			No skidding, jack-knifing or overturning			
Location at impact	Jct Approach		First impact	Back		Hit vehicle:
			Age of Driver	24		Female
Casualty Ref:	1	Vehicle: 1	Age: 24	Female	Driver/rider	Severity: Slight
Vehicle Reference	2	Car	Starting			
Vehicle movement from	NW	to SE	No tow / articulation			
			No skidding, jack-knifing or overturning			
Location at impact	Entering roundabout		First impact	Front		Hit vehicle:
			Age of Driver	23		Male

Accidents between dates 01/07/2016 and 30/06/2021 (60) months

Selection: Redditch.

Notes: Josh Norris 13.08.2021

17250156 12/12/2017 Time 1319 Vehicles 1 Casualties 1 Slight
E: 404900 N: 267896 First Road: A 441 Road Type 1
Speed limit: 40 Junction Detail: Roundabout Give way or controlled
Crossing: Control None Facilities: None within 50m Road surface Snow
Daylight:street lights present Snowing without high winds
Special Conditions at Site None

V1 HAS ENTERED TRAFFIC ISLAND OF A441 FROM SAINSBURYS DIRECTION, SKIDDED ON ICE/SLURRY AND COLLIDED WITH ISLAND REFUGE CAUSING IT TO ROLL OVER ONTO ROOF.

Occurred on A441 AT J/W A4023

Vehicle Reference 1 Car Going ahead other
Vehicle movement from W to E No tow / articulation
Skidded and overturned
Location at impact Jct Approach First impact Front Hit vehicle:
Age of Driver 50 Female
Casualty Ref: 1 Vehicle: 1 Age: 50 Female Driver/rider Severity: Slight

Accidents between dates 01/07/2016 and 30/06/2021 (60) months

Selection: Redditch.

Notes: Josh Norris 13.08.2021

18274550 04/01/2018 Time 1800 Vehicles 2 Casualties 4 Serious
 E: 404945 N: 267907 First Road: A 441 Road Type 1
 Speed limit: 40 Junction Detail: Roundabout Give way or controlled
 Crossing: Control None Facilities: None within 50m Road surface Wet/Damp
 Darkness: street lights present and lit Fine without high winds
 Special Conditions at Site None

V1 AND V2 WERE BOTH TRAVELLING AT SPEED. V1 HAS CUT UP V2 CAUSING IT TO LEAVE THE CARRIAGEWAY.
 REQUESTED BLACK BOX DATA FOR V2 TO SEE IF ANY OFFENCES HAVE BEEN COMMITTED.

Occurred on ALVECHURCH A441 AT J/W COVENTRY HIGHWAY A4023

Vehicle Reference 1 Car Changing lane to left
 Vehicle movement from NW to E No tow / articulation
 No skidding, jack-knifing or overturning
 Location at impact Leaving roundabout First impact Did not impact Hit vehicle:
 Age of Driver 34 Not traced

Vehicle Reference 2 Car Turning left
 Vehicle movement from NW to E No tow / articulation
 Skidded and overturned
 Location at impact Leaving roundabout First impact Front Hit vehicle:
 Age of Driver 18 Male

Casualty Ref: 1	Vehicle: 2	Age: 18	Male	Driver/rider	Severity: Serious
Casualty Ref: 2	Vehicle: 2	Age: 18	Male	Passenger	Severity: Slight
Casualty Ref: 3	Vehicle: 2	Age: 17	Male	Passenger	Severity: Slight
Casualty Ref: 4	Vehicle: 2	Age: 18	Female	Passenger	Severity: Serious

Accidents between dates 01/07/2016 and 30/06/2021 (60) months

Selection: Redditch.

Notes: Josh Norris 13.08.2021

18286433 14/04/2018 Time 1011 Vehicles 4 Casualties 5 Slight
 E: 403586 N: 270627 First Road: A 441 Road Type Dual carriageway
 Speed limit: 70 Junction Detail: Not within 20m of junction
 Crossing: Control None Facilities: None within 50m Road surface Dry
 Daylight:street lights present Fine without high winds
 Special Conditions at Site None

V2, V3 & V4 WERE ALL DRIVING ALONG THE A441 FROM HOPWOOD SERVICES TOWARDS REDDITCH AND WERE SLOWING TO STOP DUE TO QUEING TRAFFIC APPROACHING THE TRAFFIC ISLAND LEADING ONTO THE REDDITCH RD. V1 HAS APPROACHED FROM BEHIND AND LOST CONTROL AS IT MANOEUVRED INTO THE OUTSIDE LANE. IT HAS COLLIDED WITH V4 INITIALLY, BEFORE IMPACTING WITH V3 AND V2 BEFORE COMING TO A STANDSTILL IN THE MIDDLE OF THE DUAL CARRIAGEWAY. ON POLICE ARRIVAL THE DRIVER OF V1 WAS IDENTIFIED AND BREATHALISED. HE BLEW 94 ON THEROAD SIDE BREATH TEST AND WAS ARRESTED, WHILE ALL OTHER DRIVERS BLEW ZERO.

Occurred on BORDESLEY A441 NEAR J/W REDDITCH ROAD

Vehicle Reference 1 Car Changing lane to right
 Vehicle movement from N to S No tow / articulation
 Skidded
 Location at impact Not at, or within 20M of Jct First impact Front Hit vehicle:
 Age of Driver 35 Male

Casualty Ref: 1 Vehicle: 1 Age: 35 Male Driver/rider Severity: Slight
 Casualty Ref: 5 Vehicle: 1 Age: 31 Male Passenger Severity: Slight

Vehicle Reference 2 Car Stopping
 Vehicle movement from N to S No tow / articulation
 No skidding, jack-knifing or overturning
 Location at impact Not at, or within 20M of Jct First impact Back Hit vehicle:
 Age of Driver 73 Male

Vehicle Reference 3 Car Stopping
 Vehicle movement from N to S No tow / articulation
 No skidding, jack-knifing or overturning
 Location at impact Not at, or within 20M of Jct First impact Back Hit vehicle:
 Age of Driver 69 Male
 Casualty Ref: 2 Vehicle: 3 Age: 69 Male Driver/rider Severity: Slight
 Casualty Ref: 3 Vehicle: 3 Age: 66 Female Passenger Severity: Slight
 Casualty Ref: 4 Vehicle: 3 Age: 34 Male Passenger Severity: Slight

Vehicle Reference 4 Car Stopping
 Vehicle movement from N to S No tow / articulation
 No skidding, jack-knifing or overturning
 Location at impact Not at, or within 20M of Jct First impact Offside Hit vehicle:
 Age of Driver 39 Male

Accidents between dates 01/07/2016 and 30/06/2021 (60) months

Selection: Redditch.

Notes: Josh Norris 13.08.2021

18336287 15/10/2018 Time 1650 Vehicles 2 Casualties 1 Slight
E: 404350 N: 268477 First Road: A 441 Road Type Dual carriageway
Speed limit: 40 Junction Detail: Roundabout Give way or controlled
Crossing: Control None Facilities: None within 50m Road surface Dry
Daylight:street lights present Fine without high winds
Special Conditions at Site None

V2 WAS STATIONARY IN THE INSIDE LANE, ON THE APPROACH TO SAINSBURY'S ISLAND. V1 RAN INTO THE BACK OF V2. DRIVER OF V1 REFUSED TO EXCHANGE DETAILS.

Occurred on ALVECHURCH HIGHWAY A441 AT J/W MIDDLEHOUSE LANE B4184

Vehicle Reference	1	Car	Stopping		
Vehicle movement from	S	to NW	No tow / articulation		
Location at impact	Jct Approach		No skidding, jack-knifing or overturning		
			First impact	Front	Hit vehicle:
			Age of Driver	34	Female
Vehicle Reference	2	Car	Going ahead but held up		
Vehicle movement from	S	to NW	No tow / articulation		
Location at impact	Jct Approach		No skidding, jack-knifing or overturning		
			First impact	Back	Hit vehicle:
			Age of Driver	40	Male
Casualty Ref:	1	Vehicle: 2	Age: 40	Male	Driver/rider
					Severity: Slight

Accidents between dates 01/07/2016 and 30/06/2021 (60) months

Selection: Redditch.

Notes: Josh Norris 13.08.2021

18340341 17/10/2018 Time 1703 Vehicles 2 Casualties 1 Serious
 E: 404912 N: 267900 First Road: A 441 Road Type 1
 Speed limit: 40 Junction Detail: Roundabout Give way or controlled
 Crossing: Control None Facilities: None within 50m Road surface Dry
 Daylight:street lights present Fine without high winds
 Special Conditions at Site None

V1 WAS IN L1 WHICH HAS A SOLID WHITE LINE RUNNING ALONG THE RIGHT HAND SIDE. V1 HAS CROSSED THE SOLID WHITE LINE AND HAS COLLIDED WITH THE RIDER OF THE MOTOR BIKE V2.

Occurred on ALVECURCH HIGHWAY ISLAND A441 AT J/W COVENTRY HIGHWAY A4023

Vehicle Reference	1	Car	Changing lane to right		
Vehicle movement from	NW	to S	No tow / articulation		
			No skidding, jack-knifing or overturning		
Location at impact	Mid Junction - on roundabout or		First impact	Offside	Hit vehicle:
			Age of Driver	35	Male
Vehicle Reference	2	Motorcycle over 500cc	Going ahead other		
Vehicle movement from	NW	to S	No tow / articulation		
			No skidding, jack-knifing or overturning		
Location at impact	Mid Junction - on roundabout or		First impact	Nearside	Hit vehicle:
			Age of Driver	47	Male
Casualty Ref:	1	Vehicle: 2	Age: 47	Male	Driver/rider
					Severity: Serious

Accidents between dates 01/07/2016 and 30/06/2021 (60) months

Selection: Redditch.

Notes: Josh Norris 13.08.2021

18343509 08/11/2018 Time 1015 Vehicles 2 Casualties 1 Slight
 E: 404397 N: 268615 First Road: U Road Type Single carriageway
 Speed limit: 30 Junction Detail: Not within 20m of junction
 Crossing: Control None Facilities: None within 50m Road surface Dry
 Daylight:street lights present Fine without high winds
 Special Conditions at Site None

V1 TRAVELLING TOWARDS THE ISLAND AT THE END OF MILLRACE ROAD AROUND A SLIGHT BEND WHEN V2 CAME TOWARDS V1 FROM THE ISLAND DIRECTION ON THE WRONG SIDE OF THE ROAD AND HIT V1 HEAD ON.

Occurred on MILLRACE ROAD

Vehicle Reference	1	Car	Going ahead left bend			
Vehicle movement from	S	to W	No tow / articulation			
			No skidding, jack-knifing or overturning			
Location at impact	Not at, or within 20M of Jct		First impact	Front	Hit vehicle:	
			Age of Driver	35	Female	
Casualty Ref:	1	Vehicle: 1	Age: 35	Female	Driver/rider	Severity: Slight
Vehicle Reference	2	Car	Going ahead right bend			
Vehicle movement from	W	to S	No tow / articulation			
			No skidding, jack-knifing or overturning			
Location at impact	Not at, or within 20M of Jct		First impact	Front	Hit vehicle:	
			Age of Driver		Male	

Accidents between dates 01/07/2016 and 30/06/2021 (60) months

Selection: Redditch.

Notes: Josh Norris 13.08.2021

18346018 18/11/2018 Time 0927 Vehicles 2 Casualties 1 Slight
 E: 404371 N: 268500 First Road: A 441 Road Type Dual carriageway
 Speed limit: 70 Junction Detail: Roundabout Give way or controlled
 Crossing: Control None Facilities: None within 50m Road surface Dry
 Daylight:street lights present Fine without high winds
 Special Conditions at Site None

V1 WAS EXITING THE ROUNDABOUT TO ENTER THE ALVECHURCH HIGHWAY. THE SUN HAS CAUSED HIM TO BE DAZZELED. DRIVER HAS ASKED SON FOR SUNGLASSES AND HAS LOOKED AWAY FOR A SPLIT SECOND WHERE BY LOOKING BACK V1 HAS THEN SEEN A CYCLIST. V1 HAS SWERVED TO ATTEMPT TO MISS CAS1 BUT HAS SWIPED CAS1. CAS1 HAS THEN ENDED UP IN THE CARRIAGEWAY.

Occurred on ALVECHURCH HIGHWAY A441 AT J/W RIVERSIDE ISLAND A441

Vehicle Reference	1	Car	Going ahead other	
Vehicle movement from	N	to S	No tow / articulation	
			No skidding, jack-knifing or overturning	
Location at impact	Leaving roundabout		First impact	Nearside
			Age of Driver	47
				Hit vehicle: Male
Vehicle Reference	2	Pedal Cycle	Going ahead other	
Vehicle movement from	N	to S	No tow / articulation	
			No skidding, jack-knifing or overturning	
Location at impact	Leaving roundabout		First impact	Back
			Age of Driver	55
				Hit vehicle: Male
Casualty Ref:	1	Vehicle: 2	Age: 55	Male
			Driver/rider	Severity: Slight

Accidents between dates 01/07/2016 and 30/06/2021 (60) months

Selection: Redditch.

Notes: Josh Norris 13.08.2021

19819539 25/02/2019 Time 1940 Vehicles 2 Casualties 2 Serious
E: 404493 N: 268105 First Road: A 441 Road Type Dual carriageway
Speed limit: 40 Junction Detail: T & Stag Jct Automatic traffic signal
Crossing: Control None Facilities: None within 50m Road surface Dry
Darkness: street lights present and lit Fine without high winds
Special Conditions at Site None

V1 HAS ATTEMPTED TO STOP AT THE ATS ON THE B4160 BUT SUFFERED BRAKE FAILURE. V1 HAS CONTINUED AND COLLIDED INTO V2 ON THE A441.

Occurred on A441 ALVECHURCH HIGHWAY J/W B4160 REDDITCH RINGWAY

Vehicle Reference	1	Bus or coach	Stopping				
Vehicle movement from	SW	to NE	No tow / articulation				
			No skidding, jack-knifing or overturning				
Location at impact	Jct Approach		First impact	Front		Hit vehicle:	
			Age of Driver	56		Male	
Casualty Ref:	1	Vehicle: 1	Age: 56	Male	Driver/rider	Severity:	Slight
Vehicle Reference	2	Car	Going ahead other				
Vehicle movement from	SE	to NW	No tow / articulation				
			No skidding, jack-knifing or overturning				
Location at impact	Mid Junction - on roundabout or		First impact			Front	Hit vehicle:
			Age of Driver	37		Female	
Casualty Ref:	2	Vehicle: 2	Age: 37	Female	Driver/rider	Severity:	Serious

Accidents between dates 01/07/2016 and 30/06/2021 (60) months

Selection: Redditch.

Notes: Josh Norris 13.08.2021

19831806 18/03/2019 Time 0812 Vehicles 2 Casualties 3 Serious
 E: 404827 N: 267727 First Road: A 4023 Road Type Slip road
 Speed limit: 40 Junction Detail: Not within 20m of junction
 Crossing: Control None Facilities: None within 50m Road surface Dry
 Daylight:street lights present Fine without high winds
 Special Conditions at Site None

V1 (VAN) HAS BEEN TRAVELLING ALONG THE A441 ALVECHURCH HIGHWAY TOWARDS THE COVENTRY HIGHWAY, AND ONCE V1 HAS REACHED THE ROUNDABOUT, IT HAS TOOK FIRST EXIT (LEFT) ONTO SLIP ROAD FOR THE A4203 COVENTRY HIGHWAY TOWARDS REDDITCH TOWN CENTRE, AND WHILST ON THE START OF THE SLIP ROAD, IT HAS CHANGED INTO THE OTHER LANE ON THE SLIP ROAD, AT WHICH POINT IT HAS COLLIDED WITH V2 AT THE REAR OF IT (SMART CAR), CAUSING IT TO ROLL SEVERAL TIMES AND LAND THE CORRECT WAY UP IN L1 ON THE SLIP ROAD.

Occurred on COVENTRY HIGHWAY (A4023) WESTBOUND

Vehicle Reference	1	Goods 3.5 tonnes mgw and under	Going ahead other
Vehicle movement from	E to W	No tow / articulation	
		No skidding, jack-knifing or overturning	
Location at impact	Not at, or within 20M of Jct	First impact	Front
		Age of Driver	33
			Male
			Hit vehicle:
Casualty Ref:	1	Vehicle: 1	Age: 33
		Male	Driver/rider
		Severity:	Slight
Vehicle Reference	2	Car	Going ahead other
Vehicle movement from	E to W	No tow / articulation	
		Overturned	
Location at impact	Not at, or within 20M of Jct	First impact	Back Hit vehicle:
		Age of Driver	24
			Female
Casualty Ref:	2	Vehicle: 2	Age: 24
		Female	Driver/rider
Severity:			Serious
Casualty Ref:	3	Vehicle: 2	Age: 22
		Female	Passenger
		Severity:	Slight

Accidents between dates 01/07/2016 and 30/06/2021 (60) months

Selection: Redditch.

Notes: Josh Norris 13.08.2021

19828023 19/03/2019 Time 0725 Vehicles 2 Casualties 1 Slight
 E: 404373 N: 268626 First Road: U Road Type Single carriageway
 Speed limit: 30 Junction Detail: T & Stag Jct Give way or controlled
 Crossing: Control None Facilities: None within 50m Road surface Dry
 Daylight:street lights present Fine without high winds
 Special Conditions at Site None

V1 DRIVEN DOWN BORDESLEY IN FOLLOWING SAT NAV (NOT FROM THE AREA). SIGN FOR ROUNDABOUT AT JUNCTION WITH MILLRACE ROAD, SAT NAV INSTRUCTS TO TAKE 3RD EXIT. V1 TURNS LEFT ONTO MILLRACE ROAD BELIEVING HE WAS ON THE ROUNDABOUT SO TOOK THE INSIDE LANE FOR 3RD EXIT. V1 QUICKLY REALISED MISTAKE BUT V2 CAME ROUND THE BEND AND BEFORE V1 COULD CORRECT POSITION, THEY COLLIDED. HEAD ON.

Occurred on MILLRACE ROAD AT J/W BORDESLEY LANE

Vehicle Reference	1	Car	Starting	
Vehicle movement from	N	to SE	No tow / articulation	
			No skidding, jack-knifing or overturning	
Location at impact	Entering main road		First impact	Front
			Age of Driver	49
				Hit vehicle: Male
Vehicle Reference	2	Car	Going ahead left bend	
Vehicle movement from	SE	to SW	No tow / articulation	
			No skidding, jack-knifing or overturning	
Location at impact	Mid Junction - on roundabout or		First impact	Front
			Age of Driver	53
				Hit vehicle: Female
Casualty Ref:	1	Vehicle: 2	Age: 53	Female
			Driver/rider	Severity: Slight

Accidents between dates 01/07/2016 and 30/06/2021 (60) months

Selection: Redditch.

Notes: Josh Norris 13.08.2021

19843060 23/05/2019 Time 1400 Vehicles 2 Casualties 1 Slight
E: 404346 N: 268479 First Road: A 441 Road Type Dual carriageway
Speed limit: 30 Junction Detail: Roundabout Give way or controlled
Crossing: Control None Facilities: None within 50m Road surface Dry
Daylight:street lights present Fine without high winds
Special Conditions at Site None

V2 WAS STATIONARY AT THE ROUNDABOUT AT THE A441 ALVECHURCH HIGHWAY. V2 WAS THEN HIT FROM BEHIND BY V1.

Occurred on ALVECHURCH HIGHWAY (A441) J/W A441 ALVECHURCH HIGHWAY ISLAND REDDITCH

Vehicle Reference	1	Car	Stopping		
Vehicle movement from	S	to N	No tow / articulation		
Location at impact	Jct Approach		No skidding, jack-knifing or overturning		
			First impact	Front	Hit vehicle:
			Age of Driver	54	Female
Vehicle Reference	2	Car	Going ahead but held up		
Vehicle movement from	S	to N	No tow / articulation		
Location at impact	Jct Approach		No skidding, jack-knifing or overturning		
			First impact	Back	Hit vehicle:
			Age of Driver	28	Female
Casualty Ref:	1	Vehicle: 2	Age: 28	Female	Driver/rider
					Severity: Slight

Accidents between dates 01/07/2016 and 30/06/2021 (60) months

Selection: Redditch.

Notes: Josh Norris 13.08.2021

19875991 13/08/2019 Time 1035 Vehicles 2 Casualties 2 Serious
 E: 404130 N: 269461 First Road: A 441 Road Type Single carriageway
 Speed limit: 40 Junction Detail: T & Stag Jct Automatic traffic signal
 Crossing: Control None Facilities: None within 50m Road surface Dry
 Daylight:street lights present Fine without high winds
 Special Conditions at Site Road works

V1 WAS WAITING IN TRAFFIC AT TRAFFIC LIGHTS TO PROCEED FWD ALONG BHAM RD TWDS REDDITCH. V2 WAS WAITING IN TRAFFIC BHAM BOUND INTENDING TO TURN RIGHT TWDS DAGNELL END. V2 HAS TURNED ACROSS V1, WHO HAD PRIORITY AND WHICH RESULTED IN A COLLISION, V1 FRONT END TO F/N/S WING V2.. THIS IS CORROBORATED BY WITNESSES. THERE WERE ROAD WORKS AT THE TRAFFIC LIGHTS AND THE USUAL RIGHT FILTER LANE FOR DAGNELL END WAS CONED OFF AND LIKEWISE THE LEFT FILTER LANE FROM BHAM RD INTO DAGNELL END. ENTRY WAS FOR ACCESS ONLY. PHASING OF THE TRAFFIC LIGHTS WAS RECORDED BY PC HOLLINGWORTH ON BWV AND WAS IN WORKING ORDER.

Occurred on BIRMINGHAM ROAD (A441) J/W DAGNELL END ROAD (B4101) BORDESLEY

Vehicle Reference 1 Car Going ahead right bend
 Vehicle movement from N to SW No tow / articulation
 No skidding, jack-knifing or overturning
 Location at impact Mid Junction - on roundabout or First impact Front Hit vehicle:
 Age of Driver 33 Female

Casualty Ref: 1 Vehicle: 1 Age: 33 Female Driver/rider Severity: Serious

Vehicle Reference 2 Car Turning right
 Vehicle movement from SW to E No tow / articulation
 No skidding, jack-knifing or overturning
 Location at impact Leaving main road First impact Front Hit vehicle:
 Age of Driver 54 Male

Casualty Ref: 2 Vehicle: 2 Age: 54 Male Driver/rider Severity: Slight

Accidents between dates 01/07/2016 and 30/06/2021 (60) months

Selection: Redditch.

Notes: Josh Norris 13.08.2021

19886858 04/10/2019 Time 1415 Vehicles 2 Casualties 1 Slight
E: 404528 N: 268103 First Road: A 441 Road Type Dual carriageway
Speed limit: 40 Junction Detail: Not within 20m of junction
Crossing: Control None Facilities: None within 50m Road surface Wet/Damp
Daylight:street lights present Raining without high winds
Special Conditions at Site None

V1 HAS BEEN APPROACHING THE T/LIGHTS WITH V2 BEHIND. LIGHTS CHANGED TO AMBER AND V1 HAS STOPPED.
V2 HAS KEPT GOING, TRIED TO BRAKE AT LAST MINUTE AND DUE TO WET ROAD SURFACE HAS COLLIDED WITH
REAR V1

Occurred on ALVECHURCH HIGHWAY (A441)

Vehicle Reference 1 Car Going ahead but held up
Vehicle movement from NW to SE No tow / articulation
No skidding, jack-knifing or overturning
Location at impact Not at, or within 20M of Jct First impact Back Hit vehicle:
Age of Driver 71 Female
Casualty Ref: 1 Vehicle: 1 Age: 71 Female Driver/rider Severity: Slight

Vehicle Reference 2 Goods 3.5 tonnes mgw and under Going ahead other
Vehicle movement from NW to SE No tow / articulation
Skidded
Location at impact Not at, or within 20M of Jct First impact Front Hit vehicle:
Age of Driver 52 Male

Accidents between dates 01/07/2016 and 30/06/2021 (60) months

Selection: Redditch.

Notes: Josh Norris 13.08.2021

19907380 08/12/2019 Time 0150 Vehicles 2 Casualties 2 Serious
 E: 404924 N: 267837 First Road: A 4023 Road Type Dual carriageway
 Speed limit: 70 Junction Detail: Not within 20m of junction
 Crossing: Control None Facilities: None within 50m Road surface Wet/Damp
 Darkness: street lights present and lit Raining without high winds
 Special Conditions at Site None

V2 HAS STOPPED IN L1 OF DUAL CARRIAGEWAY. V1 HAS COLLIDED WITH THE REAR OF V2. BOTH DRIVERS OVER THE DRINK DRIVE LIMIT AT TIME OF POLICE ARRIVAL.

Occurred on COVENTRY HIGHWAY (A4023)

Vehicle Reference	1	Car	Going ahead other				
Vehicle movement from	SW	to NE	No tow / articulation				
			No skidding, jack-knifing or overturning				
Location at impact	Not at, or within 20M of Jct			First impact	Front	Hit vehicle:	
			Age of Driver	32	Male		
Casualty Ref:	1	Vehicle: 1	Age: 32	Male	Driver/rider	Severity:	Serious
Vehicle Reference	2	Car	Parked				
Vehicle movement from	Park	to Parked	No tow / articulation				
			No skidding, jack-knifing or overturning				
Location at impact	Not at, or within 20M of Jct			First impact	Back Hit vehicle:		
			Age of Driver	68	Male		
Casualty Ref:	2	Vehicle: 2	Age: 68	Male	Driver/rider	Severity:	Slight

Accidents between dates 01/07/2016 and 30/06/2021 (60) months

Selection: Redditch.

Notes: Josh Norris 13.08.2021

20917749 06/01/2020 Time 0750 Vehicles 2 Casualties 1 Slight
E: 403986 N: 269907 First Road: A 441 Road Type Single carriageway
Speed limit: 40 Junction Detail: Not within 20m of junction
Crossing: Control None Facilities: None within 50m Road surface Wet/Damp
Daylight:street lights present Fine without high winds
Special Conditions at Site None

V2 TRAVELLING IN SLOW MOVING TRAFFIC TOWARDS REDDITCH ON HIS MOTOR CYCLE. V1 PULLED OUT OF A PRIVATE DRIVEWAY, INTENDING JOINING THE CARRIAGEWAY. V1 COLLIDED WITH THE NEARSIDE OF V2,

Occurred on BIRMINGHAM ROAD (A441)

Vehicle Reference 1 Car Turning left
Vehicle movement from NE to SE No tow / articulation
No skidding, jack-knifing or overturning
Location at impact Not at, or within 20M of Jct First impact Front Hit vehicle:
Age of Driver 40 Not traced

Vehicle Reference 2 Motor Cycle over 50 cc and up to 12 Going ahead other
Vehicle movement from NW to SE No tow / articulation
No skidding, jack-knifing or overturning
Location at impact Not at, or within 20M of Jct First impact Nearside Hit vehicle:
Age of Driver 42 Male

Casualty Ref: 1 Vehicle: 2 Age: 42 Male Driver/rider Severity: Slight

Accidents between dates 01/07/2016 and 30/06/2021 (60) months

Selection: Redditch.

Notes: Josh Norris 13.08.2021

20947639 17/03/2020 Time 1100 Vehicles 1 Casualties 1 Serious
E: 404282 N: 268462 First Road: U Road Type Single carriageway
Speed limit: 30 Junction Detail: Not within 20m of junction
Crossing: Control None Facilities: None within 50m Road surface Wet/Damp
Daylight:street lights present Fine without high winds
Special Conditions at Site None

V1 LEFT THE ROUNDABOUT AT A SLOW SPEED AND ENTERED THE ABBEY RETAIL TRADING ESTATE. THE PEDESTRIAN STEPPED OUT BETWEEN THE BUSHES BEHIND THE SIGN ON THE LEFT, INTO THE PATH OF V1.

Occurred on UNCLASSIFIED ROAD - 24 METRES FROM J/W ALVECHURCH HIGHWAY (A441)

Vehicle Reference 1 Car Going ahead other
Vehicle movement from E to E No tow / articulation
No skidding, jack-knifing or overturning
Location at impact Not at, or within 20M of Jct First impact Front Hit vehicle:
Age of Driver 37 Female
Casualty Ref: 1 Vehicle: 1 Age: 50 Male Pedestrian Severity: Serious

Accidents between dates 01/07/2016 and 30/06/2021 (60) months

Selection: Redditch.

Notes: Josh Norris 13.08.2021

20944493 29/03/2020 Time 1930 Vehicles 2 Casualties 1 Slight
E: 404459 N: 268160 First Road: A 441 Road Type Dual carriageway
Speed limit: 70 Junction Detail: Not within 20m of junction
Crossing: Control None Facilities: None within 50m Road surface Dry
Darkness: street lights present and lit Fine without high winds
Special Conditions at Site None

V1 COLLIDED WITH V2. DRIVER OF V1 WAS ARRESTED AT THE SCENE.

Occurred on ALVECHURCH HIGHWAY (A441) REDDITCH

Vehicle Reference	1	Car	Overtaking moving vehicle O/S			
Vehicle movement from	NW	to SE	No tow / articulation			
			Skidded			
Location at impact	Not at, or within 20M of Jct		First impact		Nearside	Hit vehicle:
			Age of Driver	35	Male	
Casualty Ref:	1	Vehicle: 1	Age: 35	Male	Driver/rider	Severity: Slight
Vehicle Reference	2	Car	Going ahead other			
Vehicle movement from	NW	to SE	No tow / articulation			
			Skidded			
Location at impact	Not at, or within 20M of Jct		First impact		Front	Hit vehicle:
			Age of Driver	19	Male	

Accidents between dates 01/07/2016 and 30/06/2021 (60) months

Selection: Redditch.

Notes: Josh Norris 13.08.2021

20953954 22/05/2020 Time 1533 Vehicles 2 Casualties 1 Slight
 E: 404181 N: 268652 First Road: A 441 Road Type Single carriageway
 Speed limit: 40 Junction Detail: Not within 20m of junction
 Crossing: Control None Facilities: None within 50m Road surface Dry
 Daylight:street lights present Fine without high winds
 Special Conditions at Site None

DRIVER OF V1 TRAVELLED ON THE WRONG SIDE OF THE CARRIAGEWAY AND COLLIDED HEAD ON WITH V2. THE DRIVER OF V1 APPEARS TO HAVE HAD A MEDICAL EPISODE.

Occurred on ALVECHURCH HIGHWAY (A441) OPP THE PREMIER INN REDDITCH

Vehicle Reference	1	Goods 3.5 tonnes mgw and under	Going ahead other		
Vehicle movement from	NW to SE	No tow / articulation			
		No skidding, jack-knifing or overturning			
Location at impact	Not at, or within 20M of Jct	First impact	Front	Hit vehicle:	
		Age of Driver	57	Male	
Casualty Ref:	1	Vehicle: 1	Age: 57	Male	Driver/rider
					Severity: Slight
Vehicle Reference	2	Goods 3.5 tonnes mgw and under	Going ahead other		
Vehicle movement from	SE to NW	No tow / articulation			
		No skidding, jack-knifing or overturning			
Location at impact	Not at, or within 20M of Jct	First impact	Front	Hit vehicle:	
		Age of Driver	29	Male	

Accidents between dates 01/07/2016 and 30/06/2021 (60) months

Selection: Redditch.

Notes: Josh Norris 13.08.2021

20964978 07/07/2020 Time 1850 Vehicles 2 Casualties 1 Slight
 E: 404231 N: 268605 First Road: A 441 Road Type Single carriageway
 Speed limit: 40 Junction Detail: Roundabout Give way or controlled
 Crossing: Control None Facilities: None within 50m Road surface Dry
 Daylight:street lights present Fine without high winds
 Special Conditions at Site None

V1 (MARKED POLICE CAR) WAS APPROACHING THE ROUNDABOUT AND MOVING IN TO THE OFFSIDE LANE TO GO STRAIGHT AHEAD. V2 WAS ON THE ROUNDABOUT AND EXITING ON TO THE A441 BIRMINGHAM ROAD. V2 SKIDDED OVER THE CHEVRONS INTO THE LANE OF V1 AND THEN COLLIDED WITH ITS OFFSIDE REAR.

Occurred on ALVECHURCH HIGHWAY (A441) BIRMINGHAM ROAD REDDITCH J/W ALVECHURCH HIGHWAY ISLAND A441

Vehicle Reference 1 Car Stopping
 Vehicle movement from NW to SE No tow / articulation
 No skidding, jack-knifing or overturning
 Location at impact Jct Approach First impact Offside Hit vehicle:
 Age of Driver 45 Male

Casualty Ref: 1 Vehicle: 1 Age: 45 Male Driver/rider Severity: Slight

Vehicle Reference 2 Goods 3.5 tonnes mgw and under Going ahead other
 Vehicle movement from SE to NW No tow / articulation
 Skidded
 Location at impact Cleared junction or waiting/parked First impact Offside Hit vehicle:
 Age of Driver 38 Male

Accidents between dates 01/07/2016 and 30/06/2021 (60) months

Selection: Redditch.

Notes: Josh Norris 13.08.2021

20969663 22/07/2020 Time 1550 Vehicles 2 Casualties 1 Slight
 E: 404820 N: 267799 First Road: A 4023 Road Type Slip road
 Speed limit: 40 Junction Detail: Roundabout Give way or controlled
 Crossing: Control None Facilities: None within 50m Road surface Dry
 Daylight:street lights present Fine without high winds
 Special Conditions at Site None

DR/V1 WAS DRIVING UP THE SLIP ROAD OF THE A4023 TO GO ONTO THE A441 TOWARDS ALVECHURCH. WHEN HE CAME UP TO THE ISLAND HE HAS STOPPED AND LOOKED RIGHT TO SEE IF ANY CARS WERE COMING. V2 THEN HIT V1 HARD FROM THE REAR.

Occurred on COVENTRY HIGHWAY (A4023) SLIP ROAD REDDITCH J/W ALVECHURCH HIGHWAY (A441) ISLAND

Vehicle Reference	1	Car	Waiting to turn left			
Vehicle movement from	SW	to NW	No tow / articulation			
			No skidding, jack-knifing or overturning			
Location at impact	Jct Approach		First impact	Back	Hit vehicle:	
			Age of Driver	27	Male	
Casualty Ref:	1	Vehicle: 1	Age: 27	Male	Driver/rider	Severity: Slight
Vehicle Reference	2	Car	Turning left			
Vehicle movement from	SW	to NW	No tow / articulation			
			No skidding, jack-knifing or overturning			
Location at impact	Entering roundabout		First impact	Front	Hit vehicle:	
			Age of Driver	25	Male	

Accidents between dates 01/07/2016 and 30/06/2021 (60) months

Selection: Redditch.

Notes: Josh Norris 13.08.2021

20974102 11/08/2020 Time 1500 Vehicles 2 Casualties 2 Slight
 E: 404948 N: 267903 First Road: A 4023 Road Type Slip road
 Speed limit: 70 Junction Detail: Roundabout Give way or controlled
 Crossing: Control None Facilities: None within 50m Road surface Dry
 Daylight:street lights present Fine without high winds
 Special Conditions at Site None

V1 TRAVELLING FROM ALCESTER HIGHWAY AND HAS ENTERED INTO L1 IN ORDER TO GET ONTO COVENTRY HIGHWAY. V2 TRAVELLING ON THE ROUNDABOUT, AND HAS PULLED INTO L2 IN ORDER TO EXIT ONTO COVENTRY HIGHWAY. AS BOTH VEHICLE HAS ENTERED ONTO THE OFF SLIP, V1 HAS CROSSED OVER THE SOLID WHITE LINE, HITTING THE FRONT OF V2, THEN CAUSING THE DRIVER OF V2 TO SWERVE ONTO THE CENTRAL RESERVATION.

Occurred on COVENTRY HIGHWAY (A4023) SLIP ROAD REDDITCH J/W ALVECHURCH HIGHWAY (A4023) ROUNDABOUT

Vehicle Reference	1	Car	Changing lane to left			
Vehicle movement from	SW	to NE	No tow / articulation			
			No skidding, jack-knifing or overturning			
Location at impact	Leaving roundabout		First impact	Nearside		Hit vehicle:
			Age of Driver	80		Female
Casualty Ref:	1	Vehicle: 1	Age: 80	Female	Driver/rider	Severity: Slight
Vehicle Reference	2	Car	Going ahead other			
Vehicle movement from	SW	to NE	No tow / articulation			
			No skidding, jack-knifing or overturning			
Location at impact	Leaving roundabout		First impact	Offside		Hit vehicle:
			Age of Driver	33		Male
Casualty Ref:	2	Vehicle: 2	Age: 33	Male	Driver/rider	Severity: Slight

Accidents between dates 01/07/2016 and 30/06/2021 (60) months

Selection: Redditch.

Notes: Josh Norris 13.08.2021

20999464 08/11/2020 Time 1500 Vehicles 1 Casualties 1 Slight
E: 404119 N: 269632 First Road: A 441 Road Type Single carriageway
Speed limit: 40 Junction Detail: Not within 20m of junction
Crossing: Control None Facilities: None within 50m Road surface Dry
Daylight:street lights present Fine without high winds
Special Conditions at Site None

PARENT AND CHILD WERE CROSSING FROM THE WEST SIDE TO THE EAST SIDE AND WAITING FOR A GAP IN THE TRAFFIC (THERE IS NO PEDESTRIAN CROSSING POINT AT THE NEARBY TRAFFIC LIGHTS). MY DAUGHTER THOUGHT THE ROAD WAS CLEAR AND TRIED TO RUN ACROSS. UNFORTUNATELY THERE WAS A CAR COMING FROM NORTH TO SOUTH ON THE OTHER SIDE OF THE ROAD. THE DRIVER MANAGED TO AVOID HITTING HER HEAD ON, BUT SHE RAN INTO THE REAR DRIVERS SIDE OF THE CAR, AND BOUNCED OFF INTO THE MIDDLE OF THE ROAD

Occurred on BIRMINGHAM ROAD (A441) BORDESLEY 182M FROM J/W DAGNELL END ROAD (B4101)

Vehicle Reference	1	Car	Going ahead other		
Vehicle movement from	N	to S	No tow / articulation		
			No skidding, jack-knifing or overturning		
Location at impact	Not at, or within 20M of Jct		First impact	Offside	Hit vehicle:
			Age of Driver	Female	
Casualty Ref:	1	Vehicle: 1	Age: 7	Female	Pedestrian
				Severity:	Slight

Accidents between dates 01/07/2016 and 30/06/2021 (60) months

Selection: Redditch.

Notes: Josh Norris 13.08.2021

Accidents involving:

Casualties:

	Fatal	Serious	Slight	Total		Fatal	Serious	Slight	Total
Motor vehicles only (excluding 2-wheels)	0	8	18	26	Vehicle driver	0	7	23	30
					Passenger	0	1	8	9
2-wheeled motor vehicles	0	1	3	4	Motorcycle rider	0	1	3	4
					Cyclist	0	0	1	1
Pedal cycles	0	0	1	1	Pedestrian	0	1	1	2
Horses & other	0	1	1	2	Other	0	0	0	0
Total	0	9	22	31	Total	0	10	36	46

Map supplied separately.

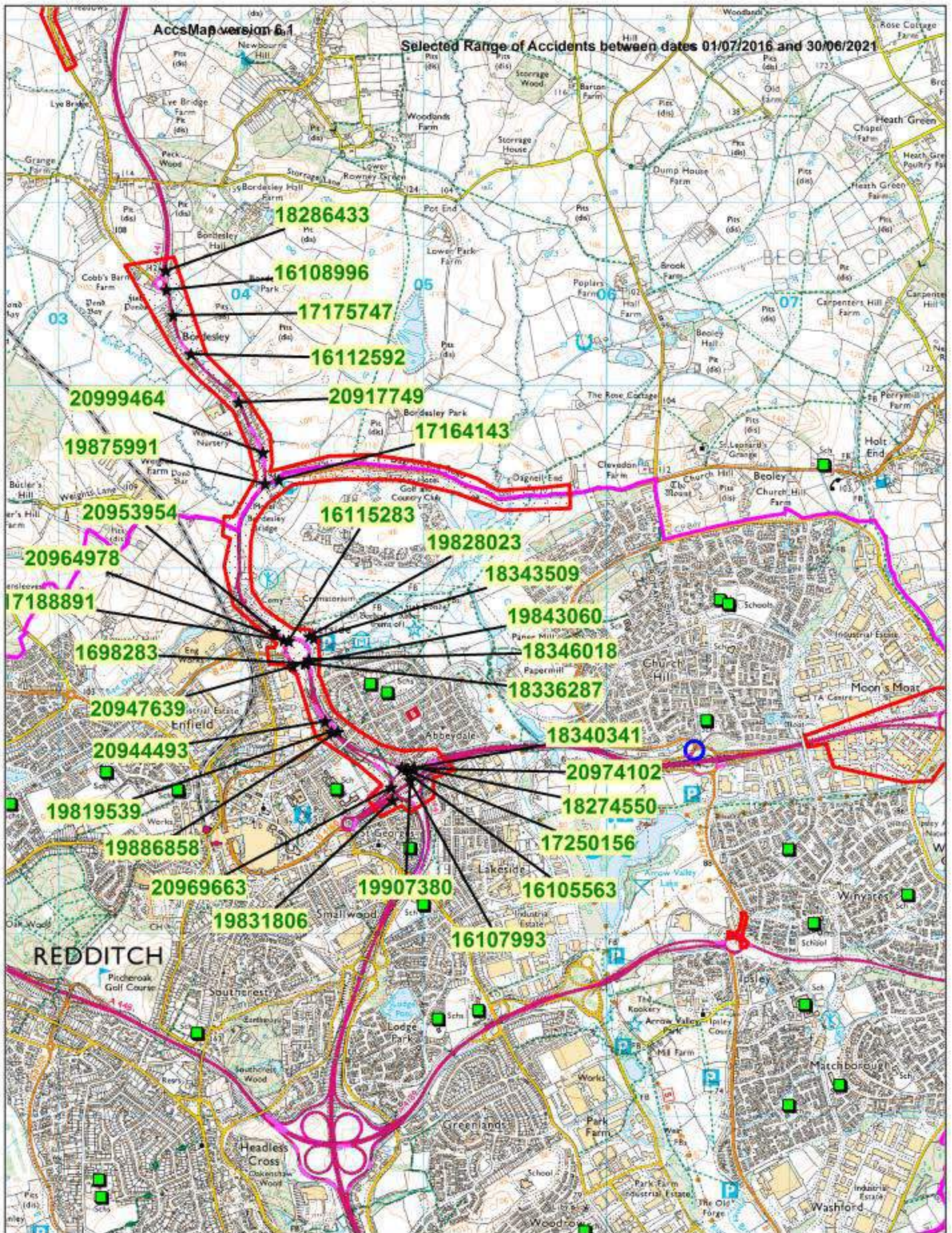

	Redditch Josh Norris KD Map1/1	+ Crown copyright. All rights reserved	
		Licence No. 100024230 2021	
		SCALE	1 : 27630
		DATE	24/08/2021
		DRAWN BY	

APPENDIX D

Highway Drawings

1 : 250

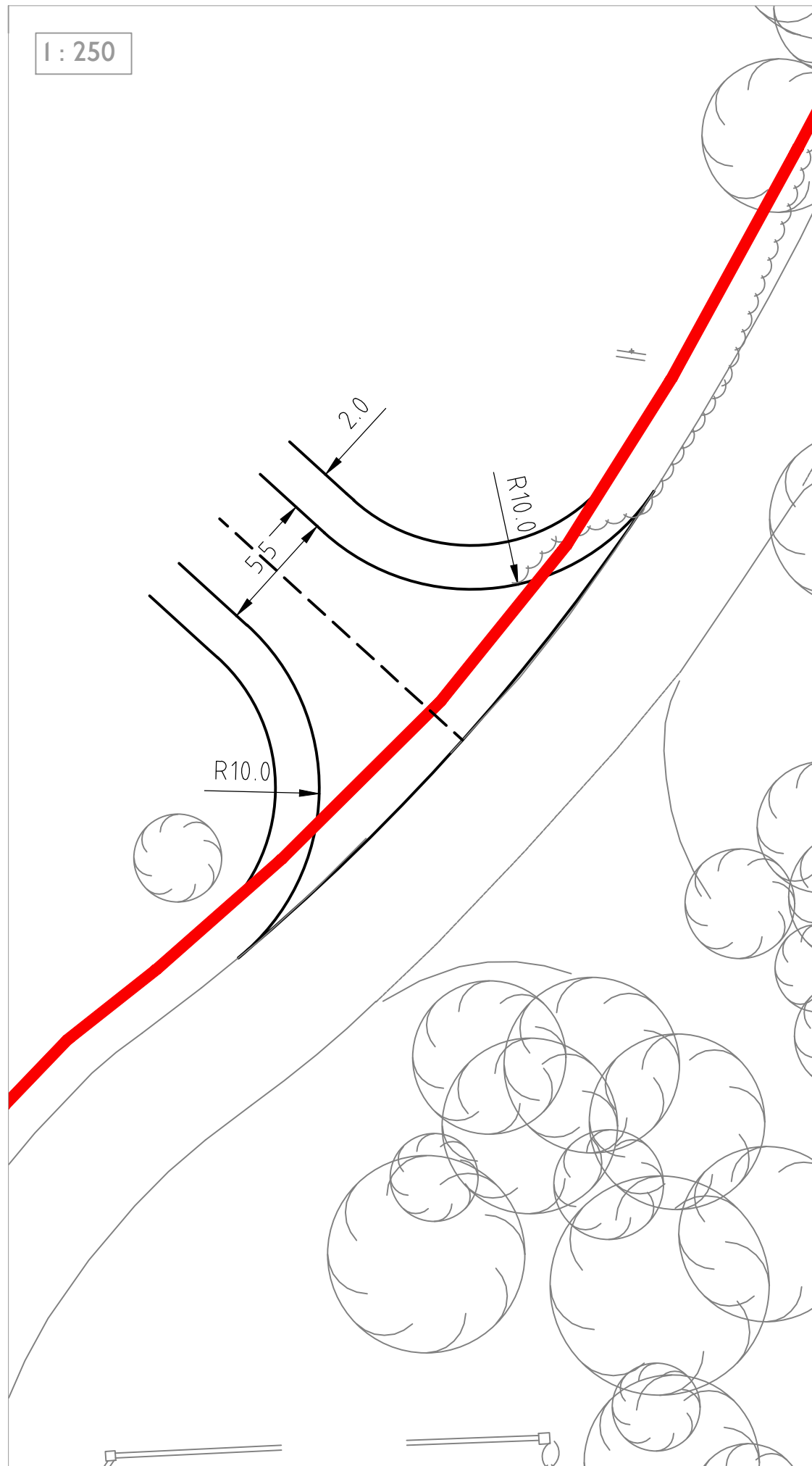

1 : 500

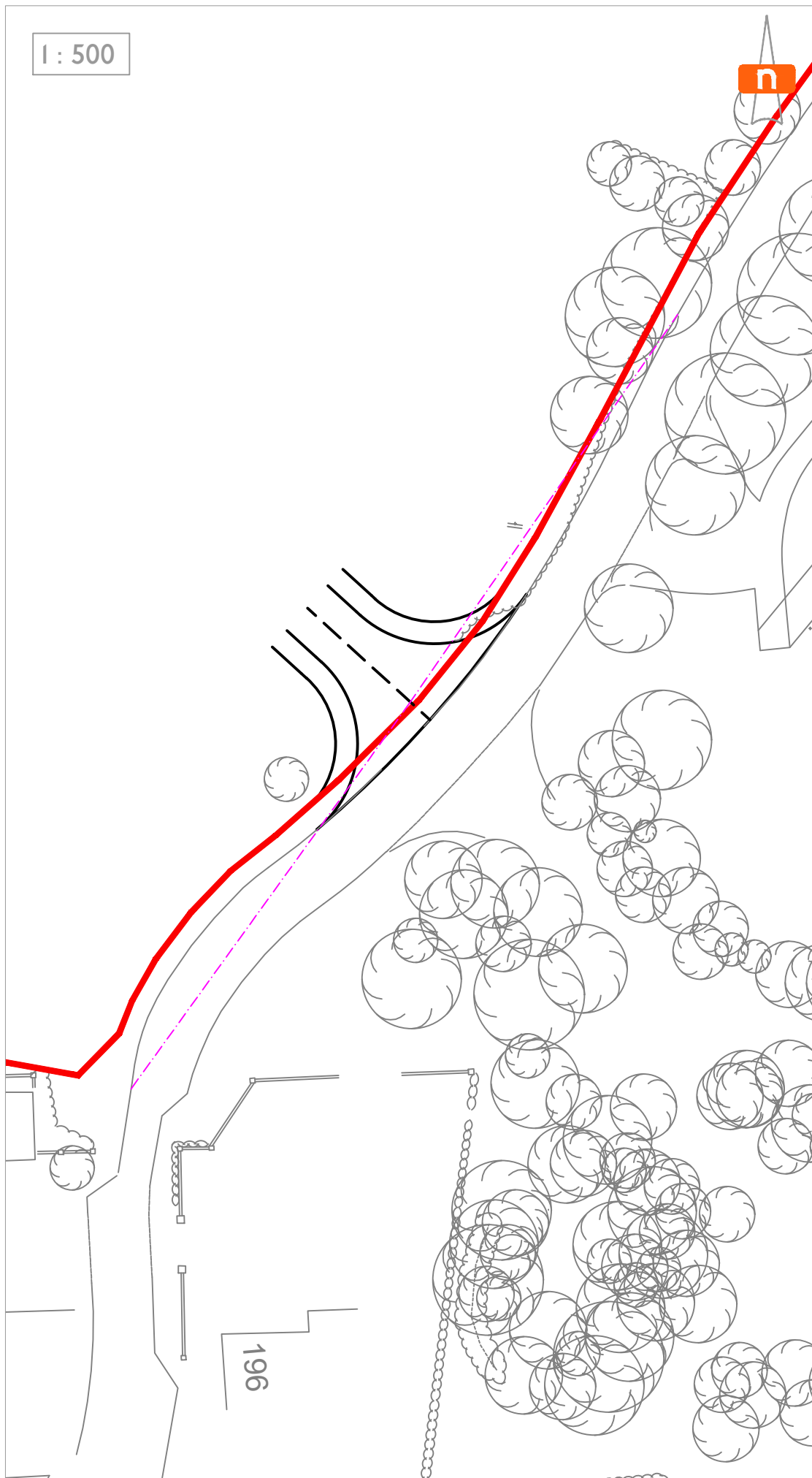

NOTE:

1. THIS DRAWING IS BASED UPON DRAWING NUMBER ME-24-2IQ BY DAVID WILSON HOMES (MERCIA).
2. THIS DRAWING IS BASED UPON THE ORDNANCE SURVEY'S (1:250) MAP WITH PERMISSION OF THE CONTROLLER OF HER MAJESTY'S STATIONERY OFFICE, CROWN COPYRIGHT RESERVED.
3. THIS DRAWING IS INDICATIVE AND SUBJECT TO DISCUSSIONS WITH LOCAL & NATIONAL HIGHWAY AUTHORITIES. THIS DESIGN IS ALSO SUBJECT TO CONFIRMATION OF LAND OWNERSHIP, TOPOGRAPHY, LOCATION OF STATUTORY SERVICES, DETAILED DESIGN AND TRAFFIC MODELLING.
4. ROAD MARKINGS & TRAFFIC SIGNS ARE TO BE IN ACCORDANCE WITH 'THE TRAFFIC SIGNS REGULATIONS AND GENERAL DIRECTIONS 2016'
5. DO NOT SCALE FROM THIS DRAWING WORK FROM FIGURED DIMENSIONS ONLY.
6. ALL DIMENSIONS ARE SHOWN IN METRES UNLESS NOTED OTHERWISE.

KEY:

- SITE BOUNDARY
- - - VISIBILITY SPLAY 2.4m x 43m (30mph)
(VISIBILITY SPLAYS ARE BASED UPON MIS STANDARDS)

REV	DATE	REMARKS
A	15.10.2021	REVISED LAYOUT
-	25.08.2021	INITIAL ISSUE

CLIENT

DAVID WILSON HOMES (MERCIA)

JOB TITLE

HITHER GREEN LANE, REDDITCH

DRAWING TITLE

PROPOSED ACCESS STRATEGY
VEHICULAR ACCESS - HITHER GREEN LANE

DRAWING NO.

J32-5756-PS-001

DRAWN

JN

CHECKED

JB / AS

CREATED

AUG '21

SCALE

VARIES @A3

mode transport planning
LOMBARD HOUSE
145 GREAT CHARLES STREET
BIRMINGHAM
B3 3LP



T 0121 794 8390
E INFO@MODETRANSPORT.CO.UK
W WWW.MODETRANSPORT.CO.UK

transport planning

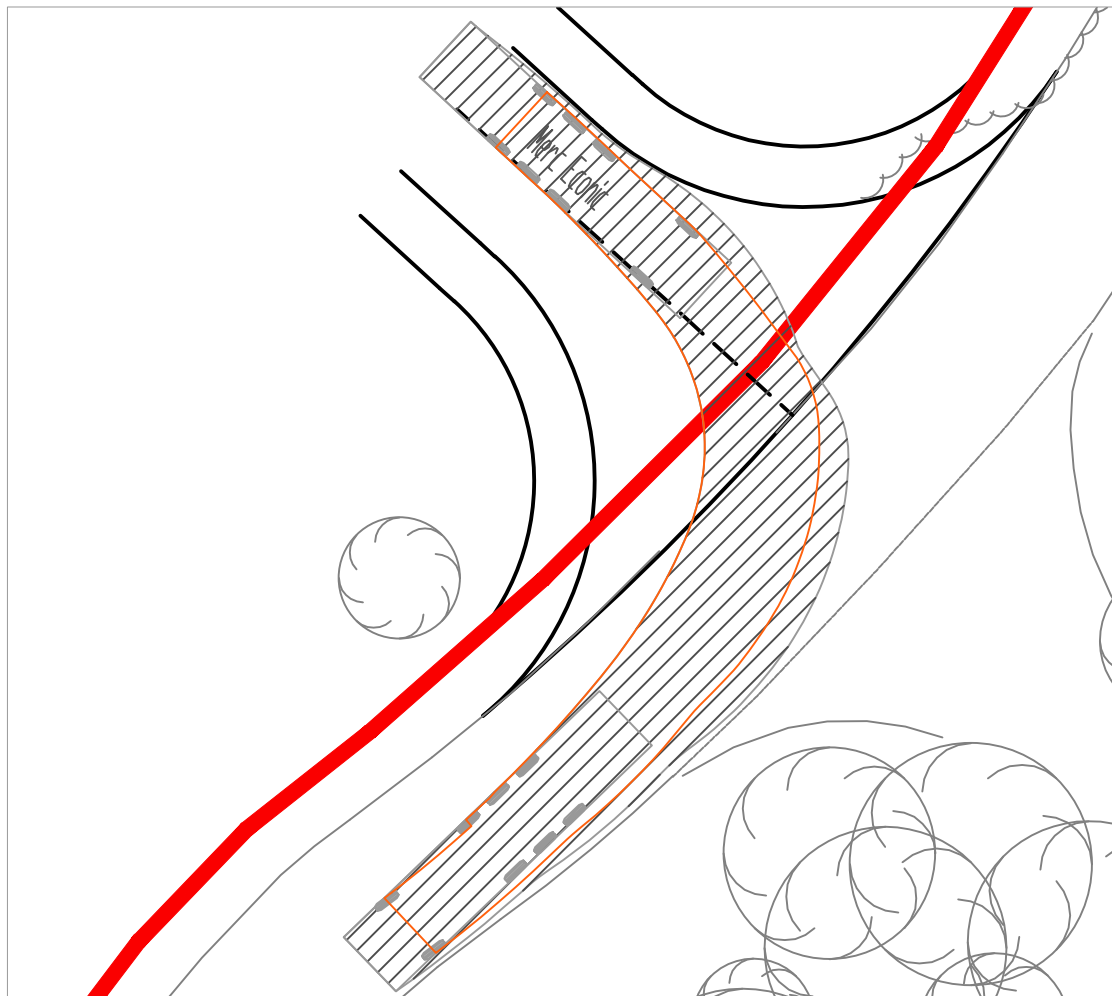
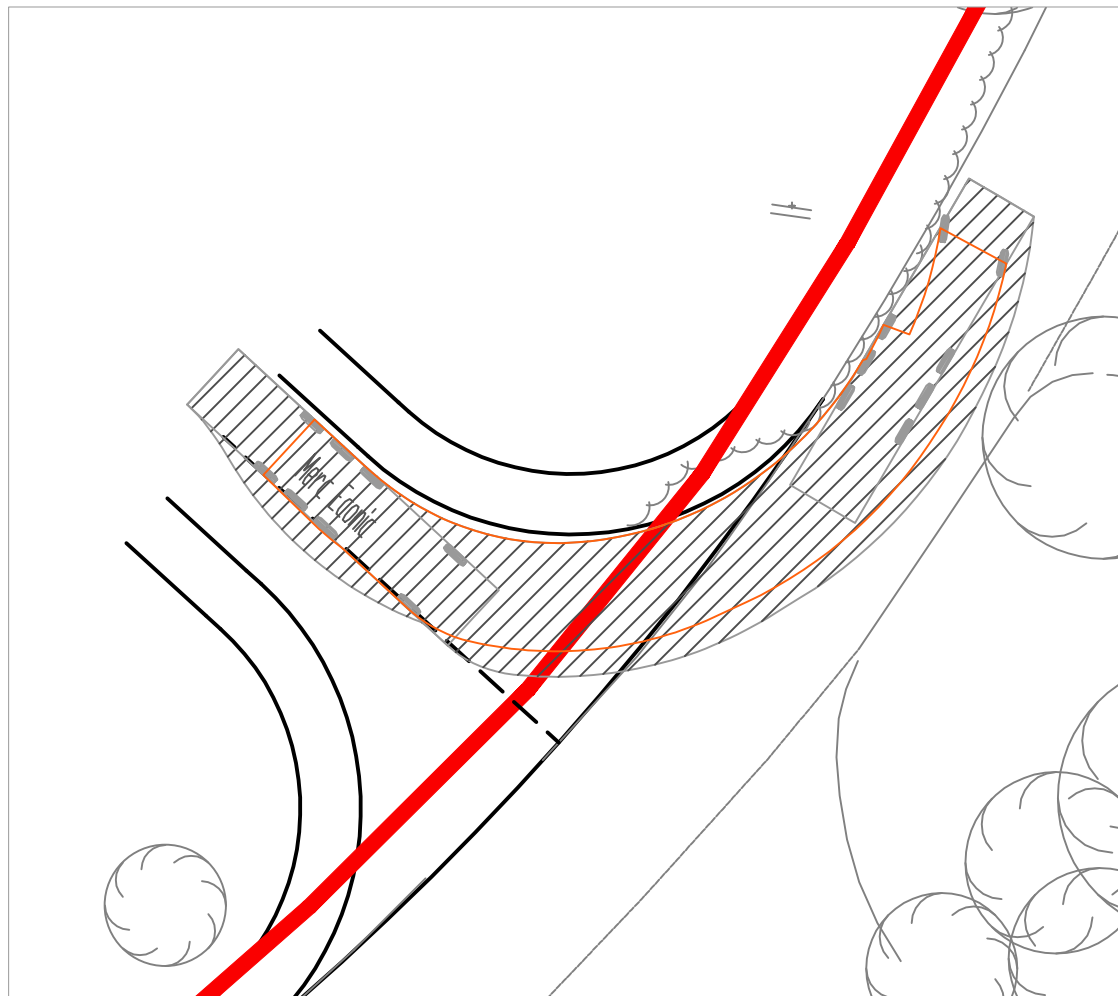
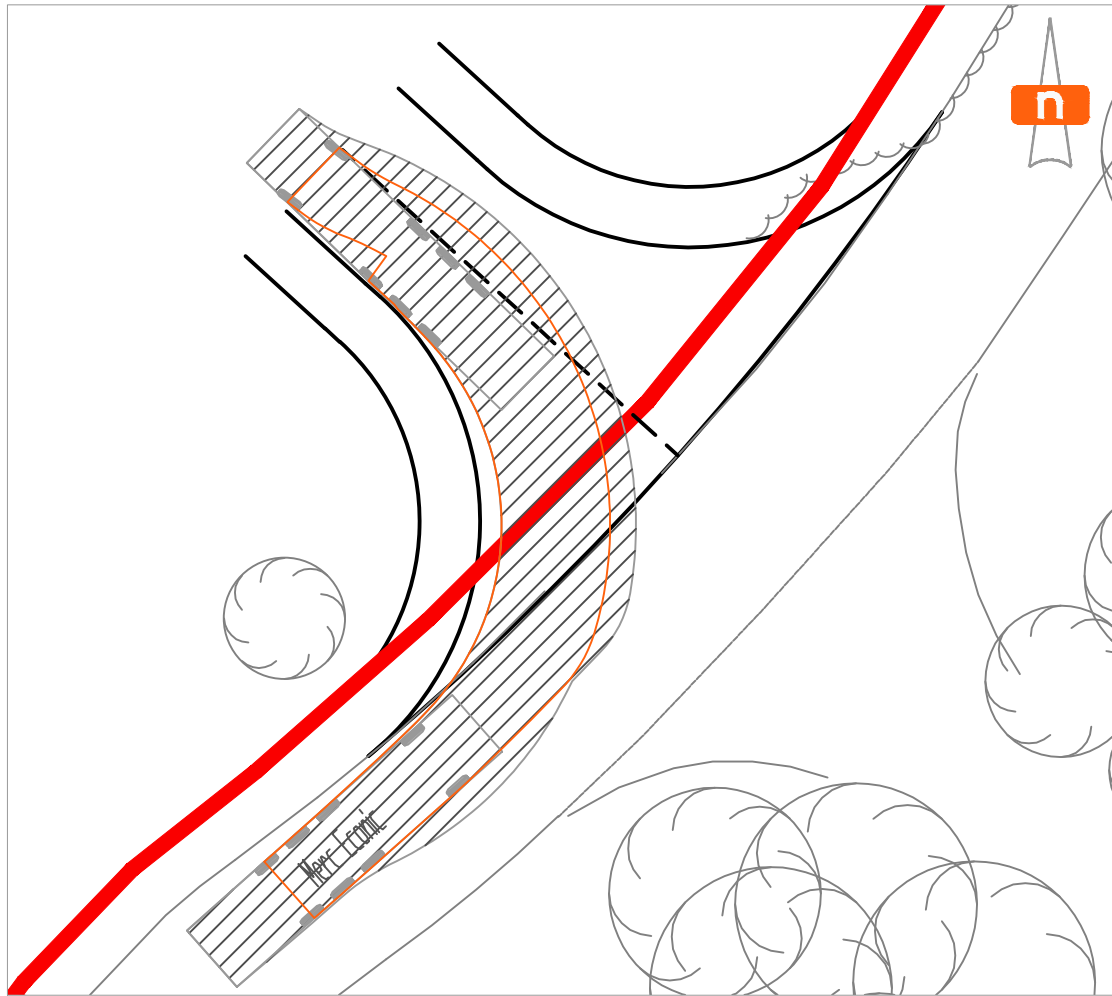
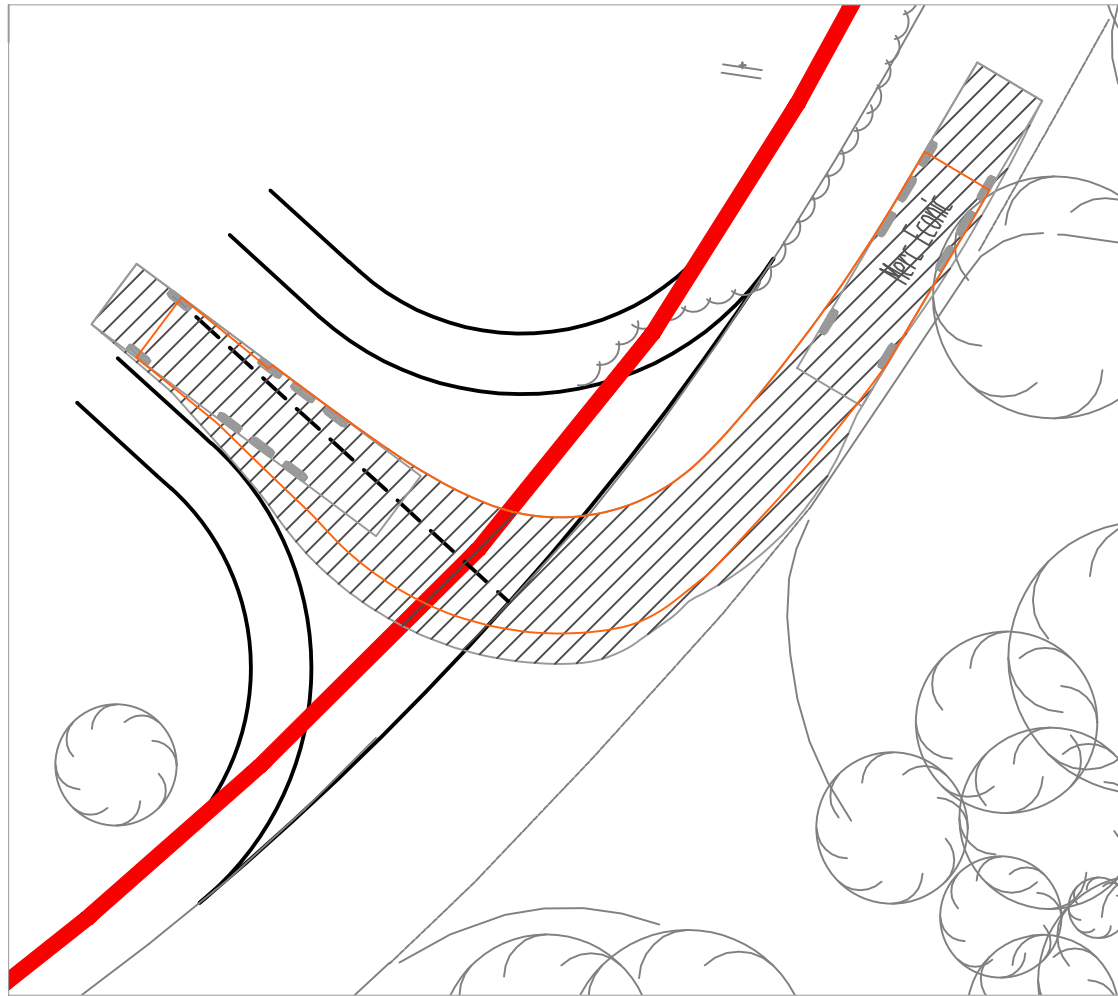

NOTE:

1. THIS DRAWING IS BASED UPON DRAWING NUMBER ME-24-2IQ BY DAVID WILSON HOMES (MERCIA).
2. THIS DRAWING IS BASED UPON THE ORDNANCE SURVEY'S (1:250) MAP WITH PERMISSION OF THE CONTROLLER OF HER MAJESTY'S STATIONERY OFFICE, CROWN COPYRIGHT RESERVED.
3. THIS DRAWING IS INDICATIVE AND SUBJECT TO DISCUSSIONS WITH LOCAL & NATIONAL HIGHWAY AUTHORITIES. THIS DESIGN IS ALSO SUBJECT TO CONFIRMATION OF LAND OWNERSHIP, TOPOGRAPHY, LOCATION OF STATUTORY SERVICES, DETAILED DESIGN AND TRAFFIC MODELLING.
4. ROAD MARKINGS & TRAFFIC SIGNS ARE TO BE IN ACCORDANCE WITH 'THE TRAFFIC SIGNS REGULATIONS AND GENERAL DIRECTIONS 2016'
5. DO NOT SCALE FROM THIS DRAWING WORK FROM FIGURED DIMENSIONS ONLY.
6. ALL DIMENSIONS ARE SHOWN IN METRES UNLESS NOTED OTHERWISE.

KEY:

— SITE BOUNDARY

VEHICLE PROFILE:

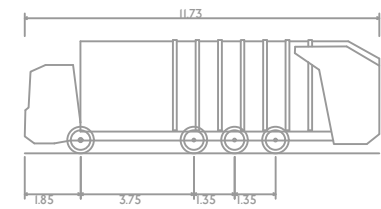

Merc Eonic
 Overall Length 11.730m
 Overall Width 2.490m
 Overall Body Height 3.749m
 Min Body Ground Clearance 0.302m
 Track Width 2.490m
 Lock to lock time 4.00s
 Max Steering Angle (Virtual) 33.00°

REV	DATE	REMARKS
A	15.10.2021	REVISED LAYOUT
-	25.08.2021	INITIAL ISSUE

CLIENT

DAVID WILSON HOMES (MERCIA)

JOB TITLE

HITHER GREEN LANE, REDDITCH

DRAWING TITLE

SITE ACCESS - REFUSE VEHICLE
 SWEEP-PATH ANALYSIS

DRAWING NO.

J32-5756-PS-002

DRAWN
 JN

CHECKED
 JB / AS

CREATED
 AUG' 21

SCALE
 1:250 @A3

mode transport planning
 LOMBARD HOUSE
 145 GREAT CHARLES STREET
 BIRMINGHAM
 B3 3LP



T 0121 794 8390
 E INFO@MODETRANSPORT.CO.UK
 W WWW.MODETRANSPORT.CO.UK

transport planning

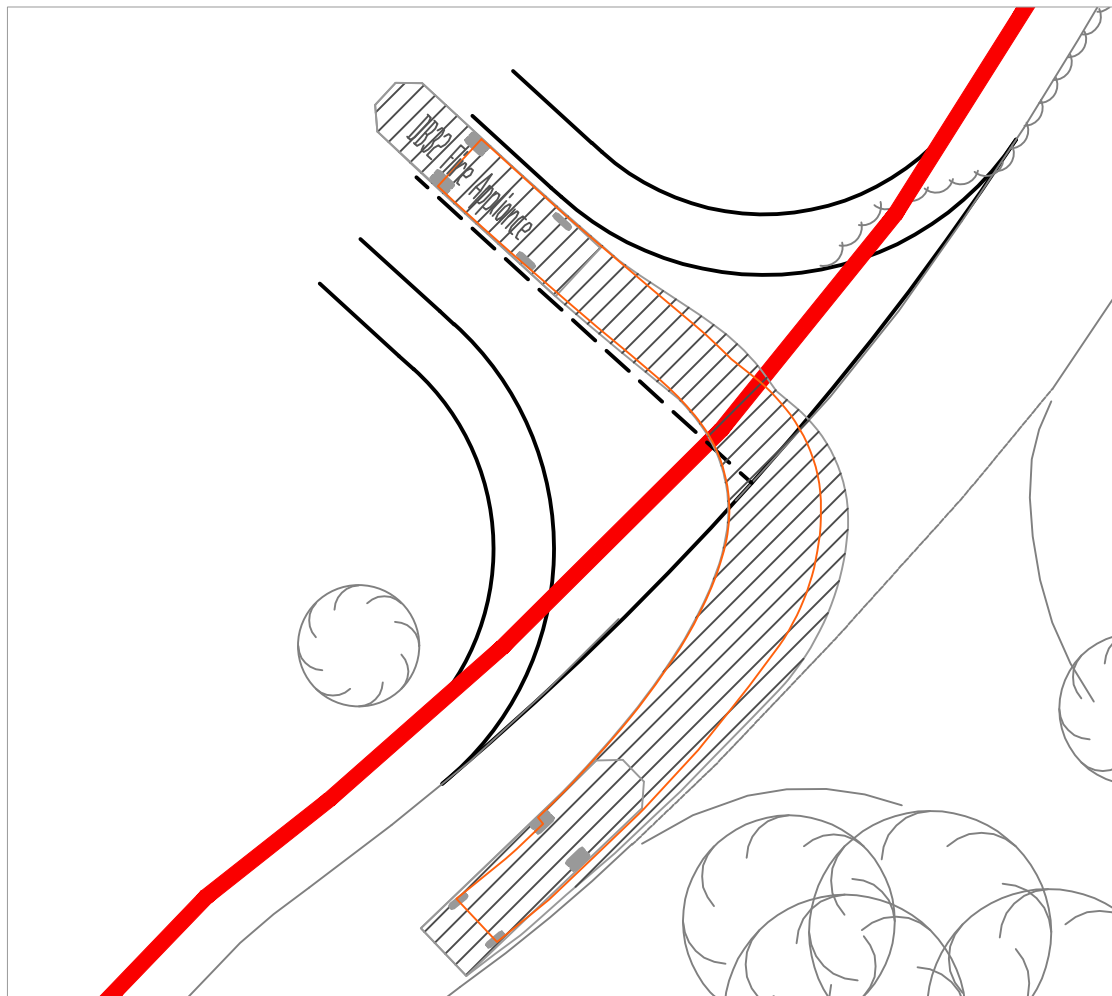
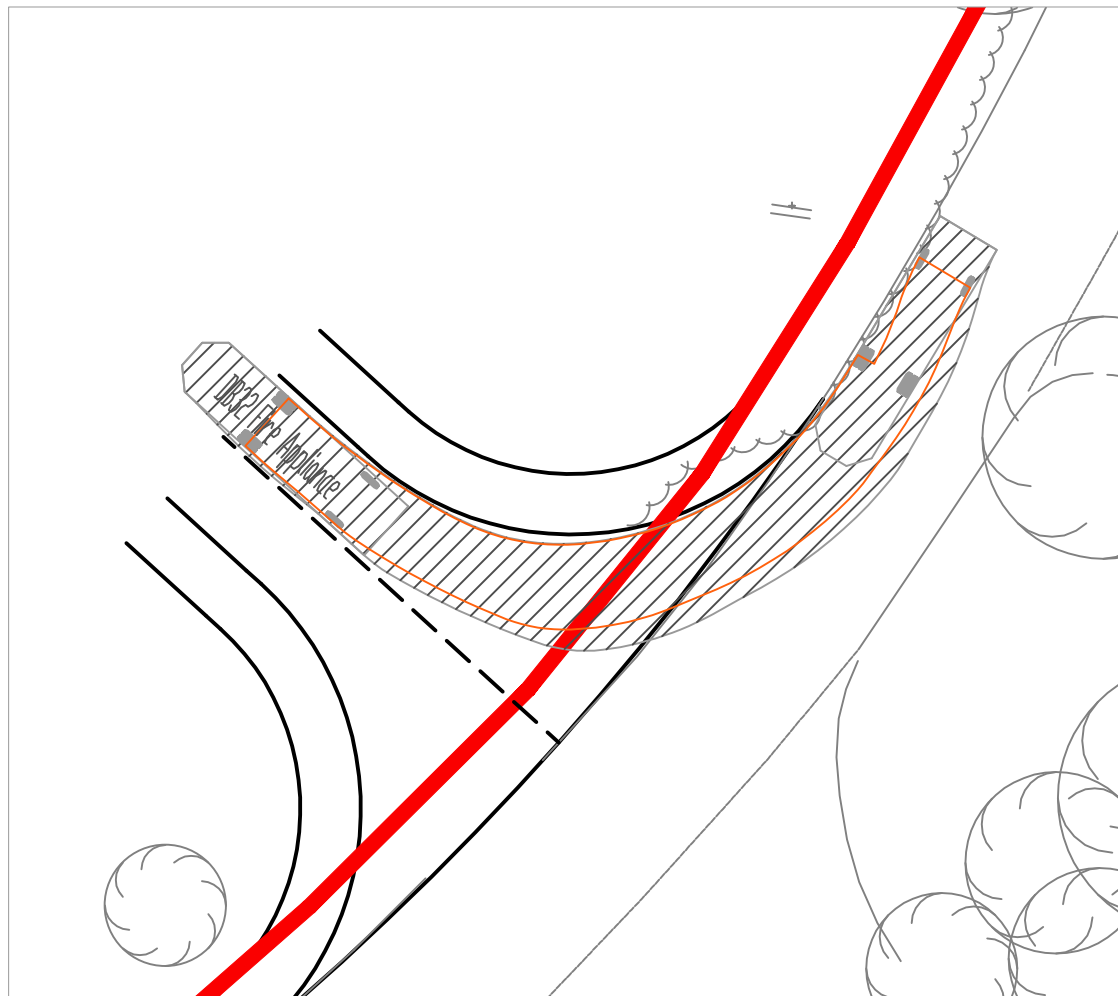
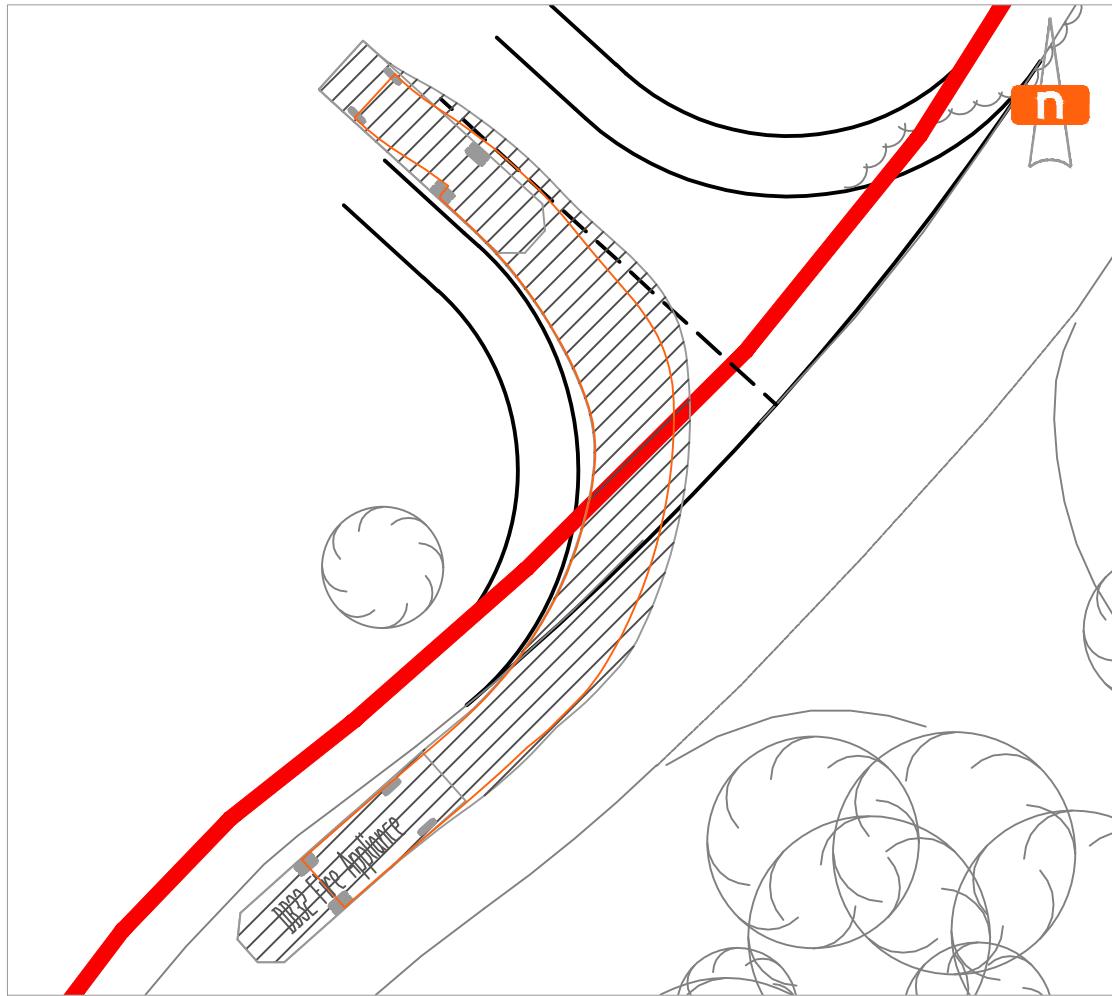
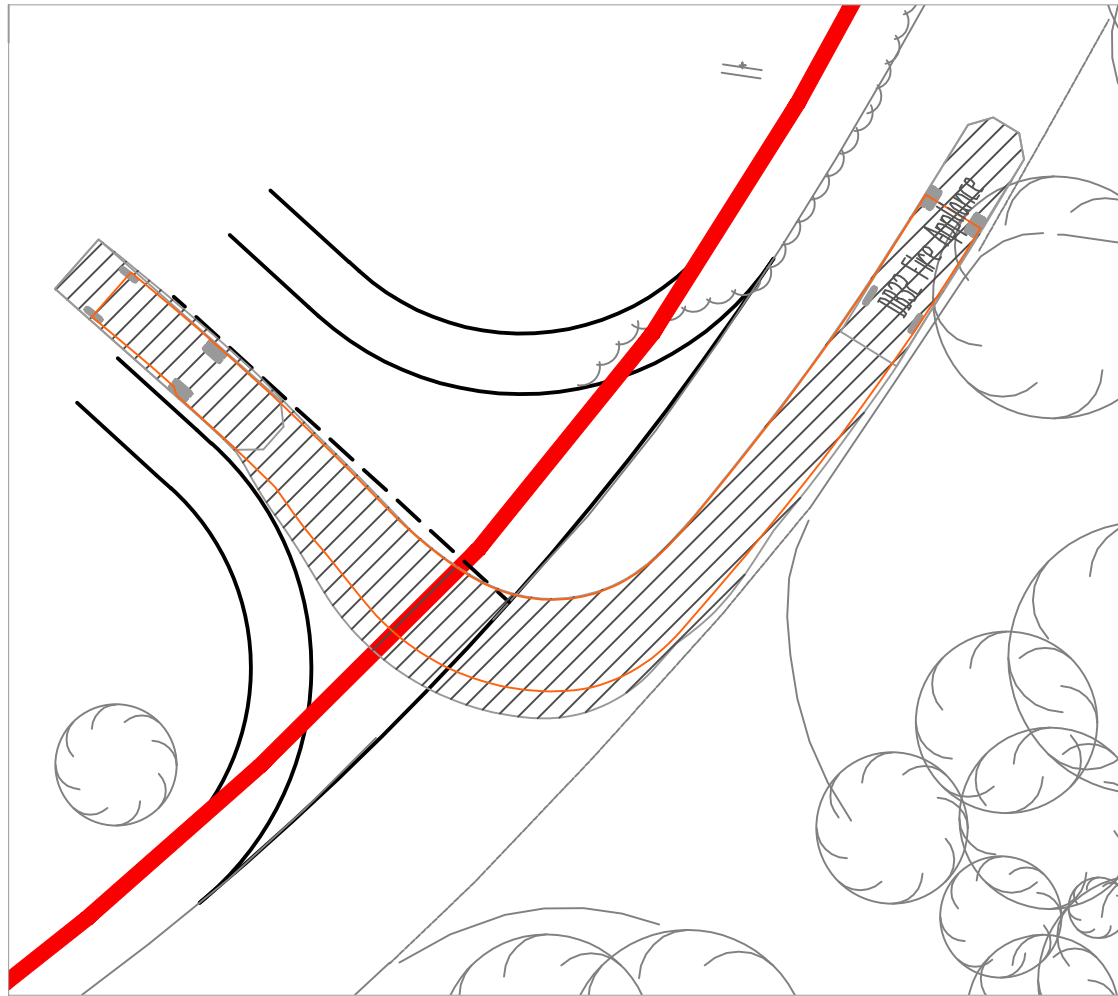

NOTE:

1. THIS DRAWING IS BASED UPON DRAWING NUMBER ME-24-2IQ BY DAVID WILSON HOMES (MERCIA).
2. THIS DRAWING IS BASED UPON THE ORDNANCE SURVEY'S (1:250) MAP WITH PERMISSION OF THE CONTROLLER OF HER MAJESTY'S STATIONERY OFFICE, CROWN COPYRIGHT RESERVED.
3. THIS DRAWING IS INDICATIVE AND SUBJECT TO DISCUSSIONS WITH LOCAL & NATIONAL HIGHWAY AUTHORITIES. THIS DESIGN IS ALSO SUBJECT TO CONFIRMATION OF LAND OWNERSHIP, TOPOGRAPHY, LOCATION OF STATUTORY SERVICES, DETAILED DESIGN AND TRAFFIC MODELLING.
4. ROAD MARKINGS & TRAFFIC SIGNS ARE TO BE IN ACCORDANCE WITH 'THE TRAFFIC SIGNS REGULATIONS AND GENERAL DIRECTIONS 2016'
5. DO NOT SCALE FROM THIS DRAWING WORK FROM FIGURED DIMENSIONS ONLY.
6. ALL DIMENSIONS ARE SHOWN IN METRES UNLESS NOTED OTHERWISE.

KEY:

— SITE BOUNDARY

VEHICLE PROFILE:

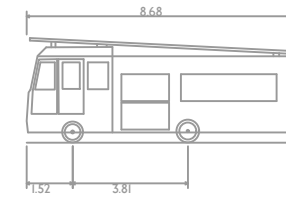

DB32 Fire Appliance
 Overall Length 8.680m
 Overall Width 2.180m
 Overall Body Height 3.452m
 Min Body Ground Clearance 0.337m
 Max Track Width 2.121m
 Lock to lock time 6.00s
 Kerb to Kerb Turning Radius 7.910m

REV	DATE	REMARKS
A	15.10.2021	REVISED LAYOUT
-	25.08.2021	INITIAL ISSUE

CLIENT

DAVID WILSON HOMES (MERCIA)

JOB TITLE
 HITHER GREEN LANE, REDDITCH

DRAWING TITLE
 SITE ACCESS - FIRE TENDER
 SWEEP-PATH ANALYSIS

DRAWING NO.
 J32-5756-PS-003

DRAWN	JN	CHECKED	JB / AS
CREATED	AUG' 21	SCALE	1:250 @A3

mode transport planning
 LOMBARD HOUSE
 145 GREAT CHARLES STREET
 BIRMINGHAM
 B3 3LP

T 0121 794 8390
 E INFO@MODETRANSPORT.CO.UK
 W WWW.MODETRANSPORT.CO.UK



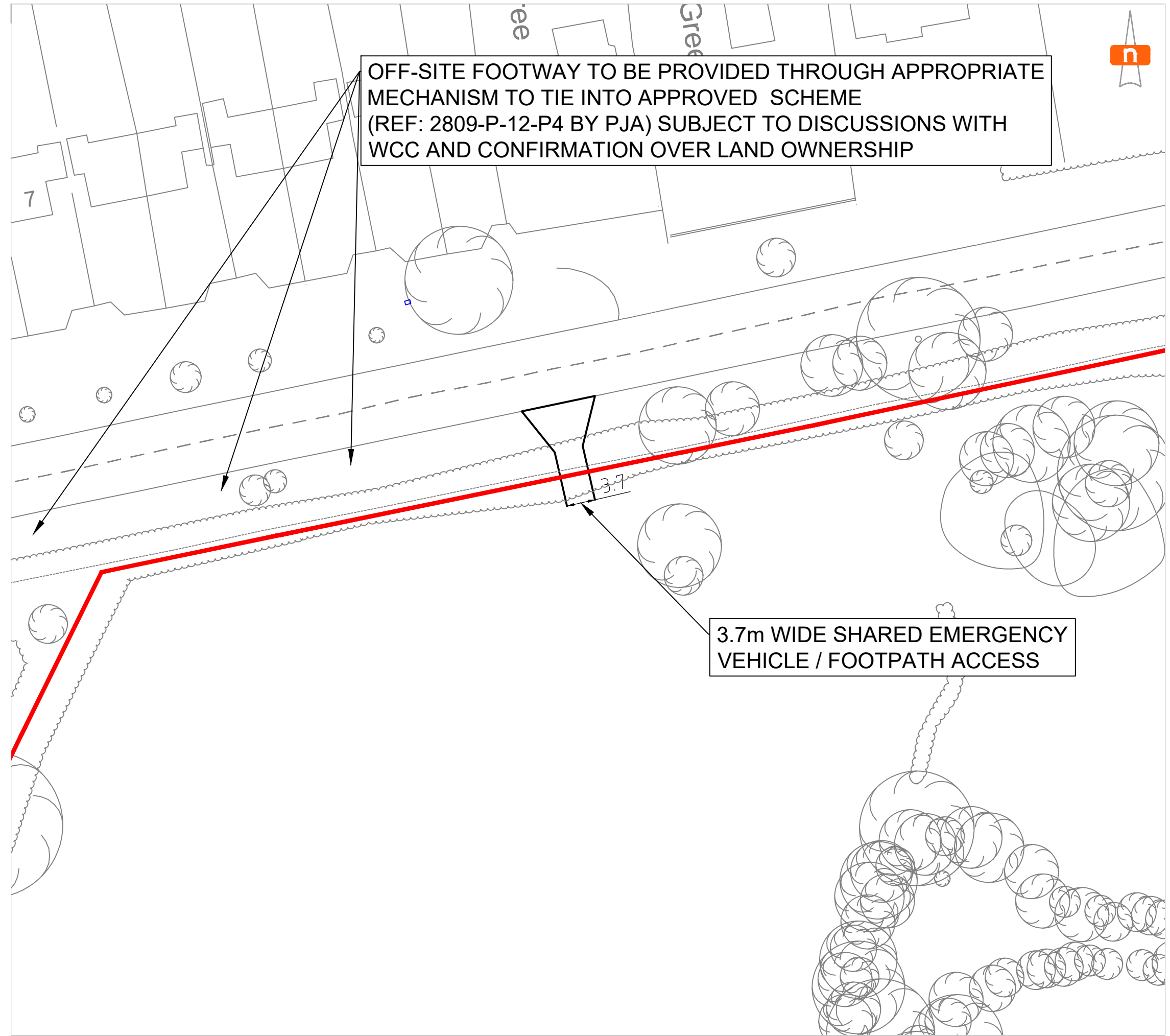

OFF-SITE FOOTWAY TO BE PROVIDED THROUGH APPROPRIATE MECHANISM TO TIE INTO APPROVED SCHEME (REF: 2809-P-12-P4 BY PJA) SUBJECT TO DISCUSSIONS WITH WCC AND CONFIRMATION OVER LAND OWNERSHIP

3.7m WIDE SHARED EMERGENCY VEHICLE / FOOTPATH ACCESS

NOTE:

1. THIS DRAWING IS BASED UPON DRAWING NUMBER ME-24-2IQ BY DAVID WILSON HOMES (MERCIA).
2. THIS DRAWING IS BASED UPON THE ORDNANCE SURVEY'S (1:250) MAP WITH PERMISSION OF THE CONTROLLER OF HER MAJESTY'S STATIONERY OFFICE, CROWN COPYRIGHT RESERVED.
3. THIS DRAWING IS INDICATIVE AND SUBJECT TO DISCUSSIONS WITH LOCAL & NATIONAL HIGHWAY AUTHORITIES. THIS DESIGN IS ALSO SUBJECT TO CONFIRMATION OF LAND OWNERSHIP, TOPOGRAPHY, LOCATION OF STATUTORY SERVICES, DETAILED DESIGN AND TRAFFIC MODELLING.
4. ROAD MARKINGS & TRAFFIC SIGNS ARE TO BE IN ACCORDANCE WITH 'THE TRAFFIC SIGNS REGULATIONS AND GENERAL DIRECTIONS 2016'
5. DO NOT SCALE FROM THIS DRAWING WORK FROM FIGURED DIMENSIONS ONLY.
6. ALL DIMENSIONS ARE SHOWN IN METRES UNLESS NOTED OTHERWISE.

KEY:

— SITE BOUNDARY

REV	DATE	REMARKS
A	15.10.2021	REVISED LAYOUT
-	25.08.2021	INITIAL ISSUE

CLIENT
DAVID WILSON HOMES (MERCIA)

JOB TITLE
HITHER GREEN LANE, REDDITCH

DRAWING TITLE
**PROPOSED ACCESS STRATEGY
EMERGENCY VEHICLE / PEDESTRIAN ACCESS**

DRAWING NO.
J32-5756-PS-004

DRAWN	JN	CHECKED	JB / AS
CREATED	AUG' 21	SCALE	1:500 @A3

mode transport planning
 LOMBARD HOUSE
 145 GREAT CHARLES STREET
 BIRMINGHAM
 B3 3LP



T 0121 794 8390
 E INFO@MODETRANSPORT.CO.UK
 W WWW.MODETRANSPORT.CO.UK

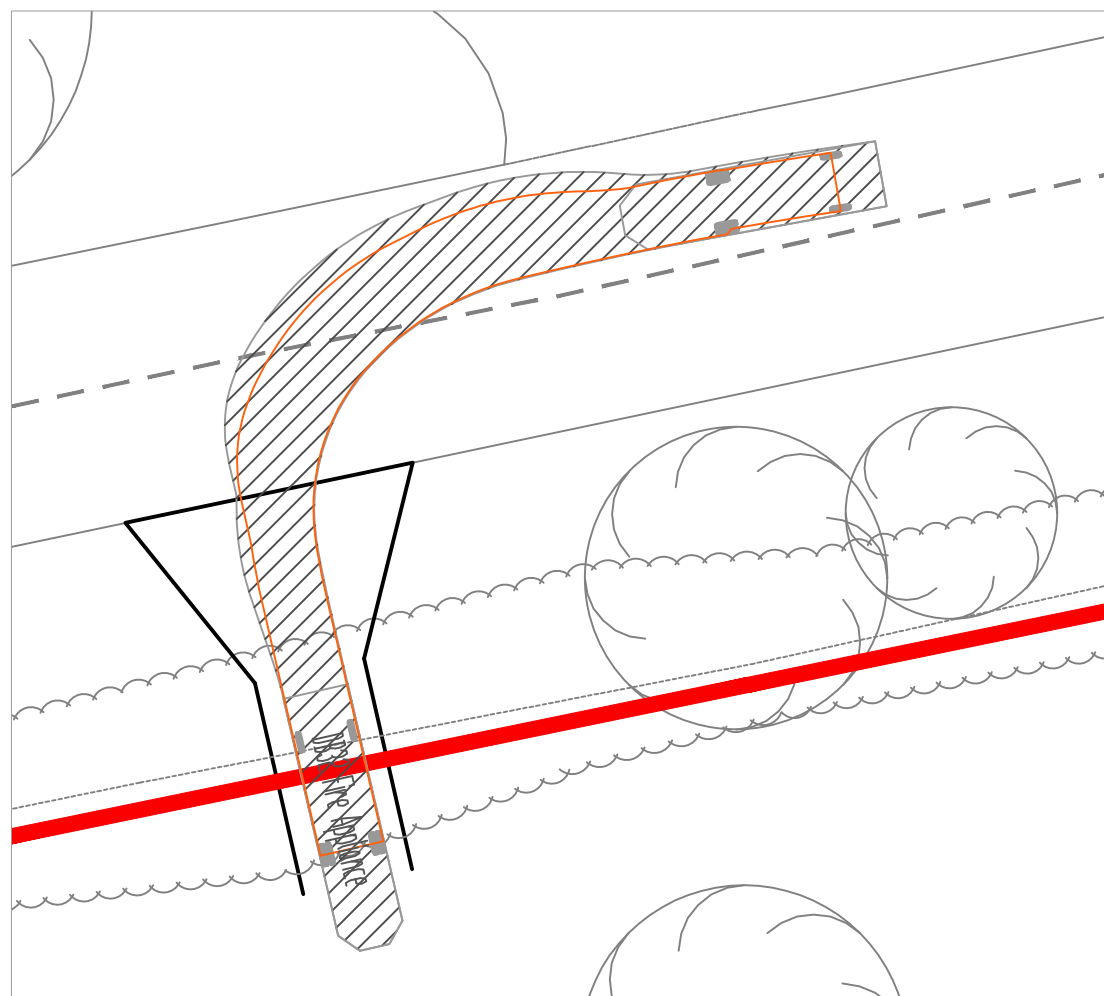
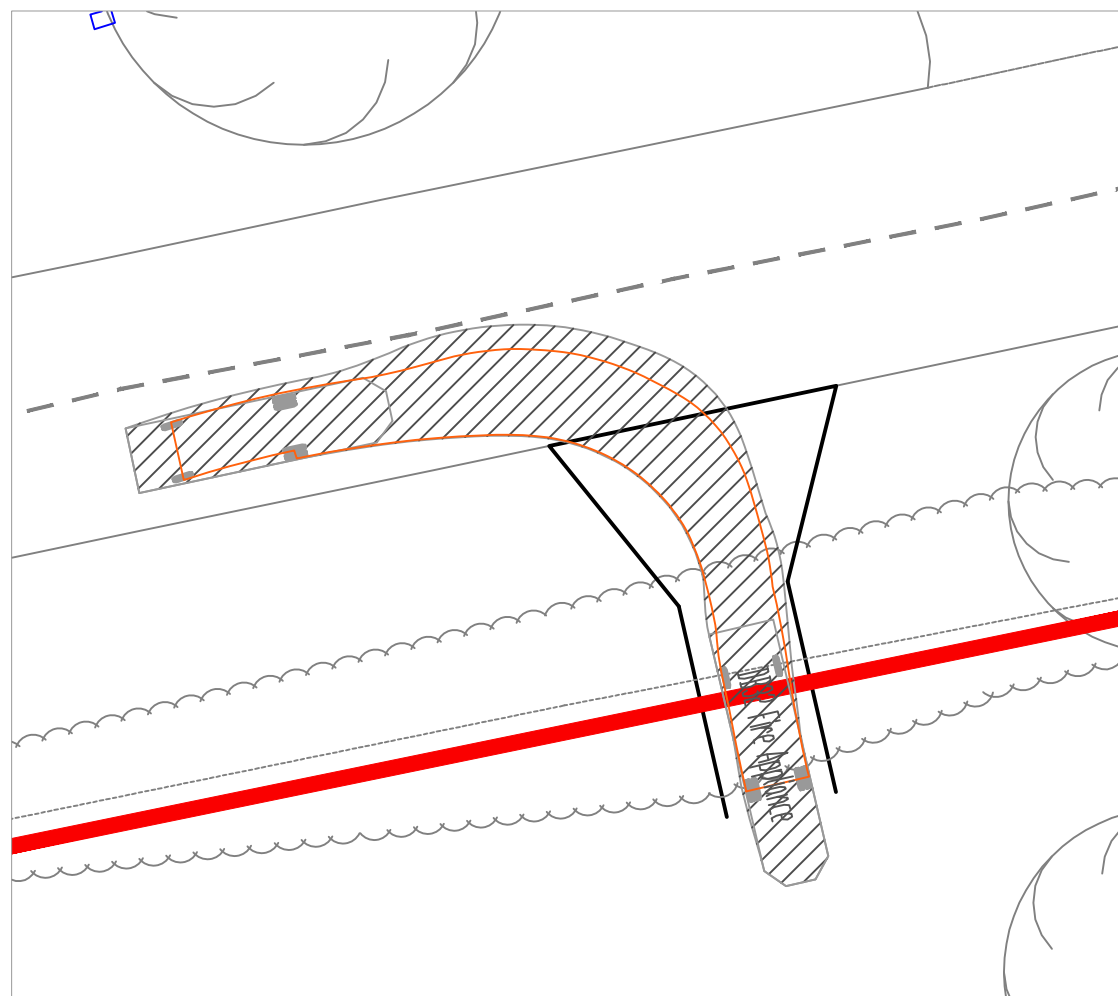
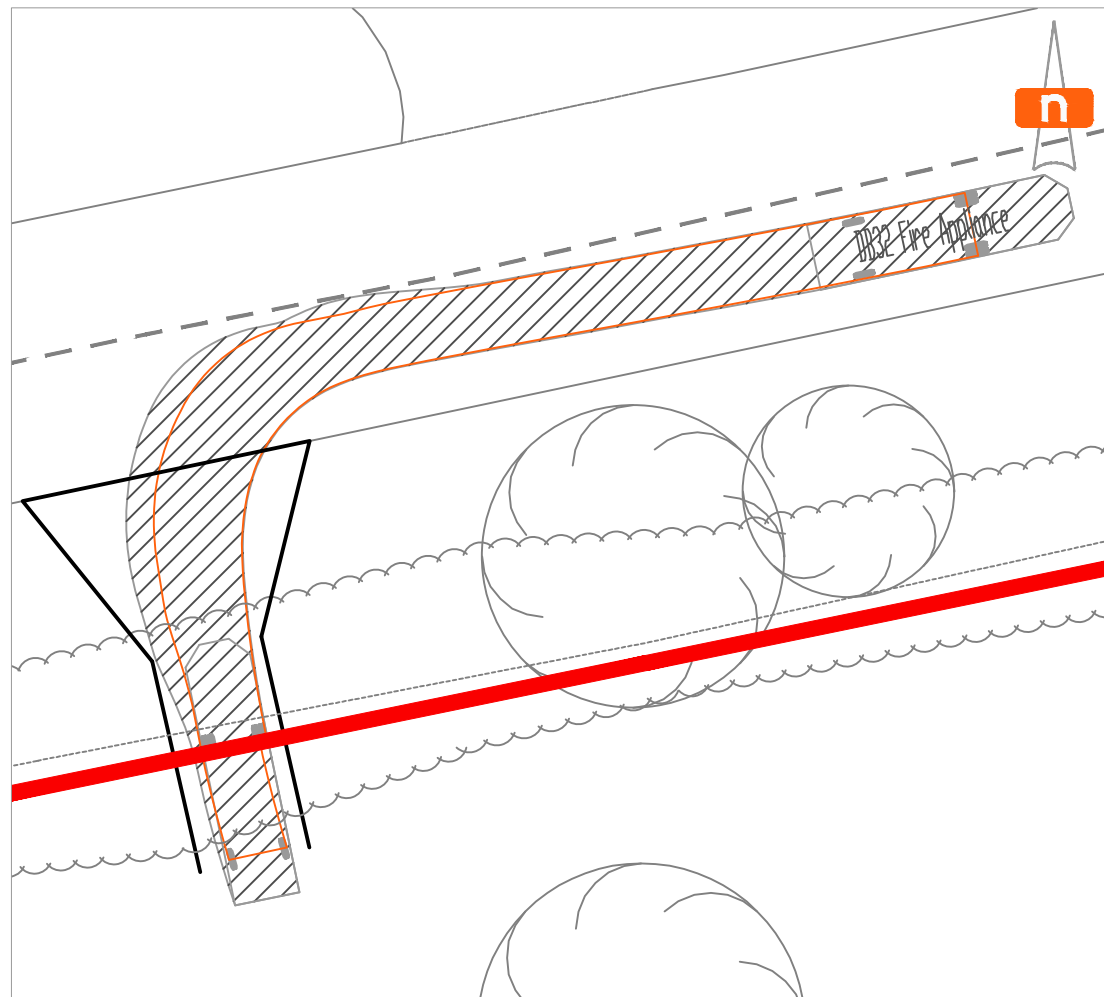
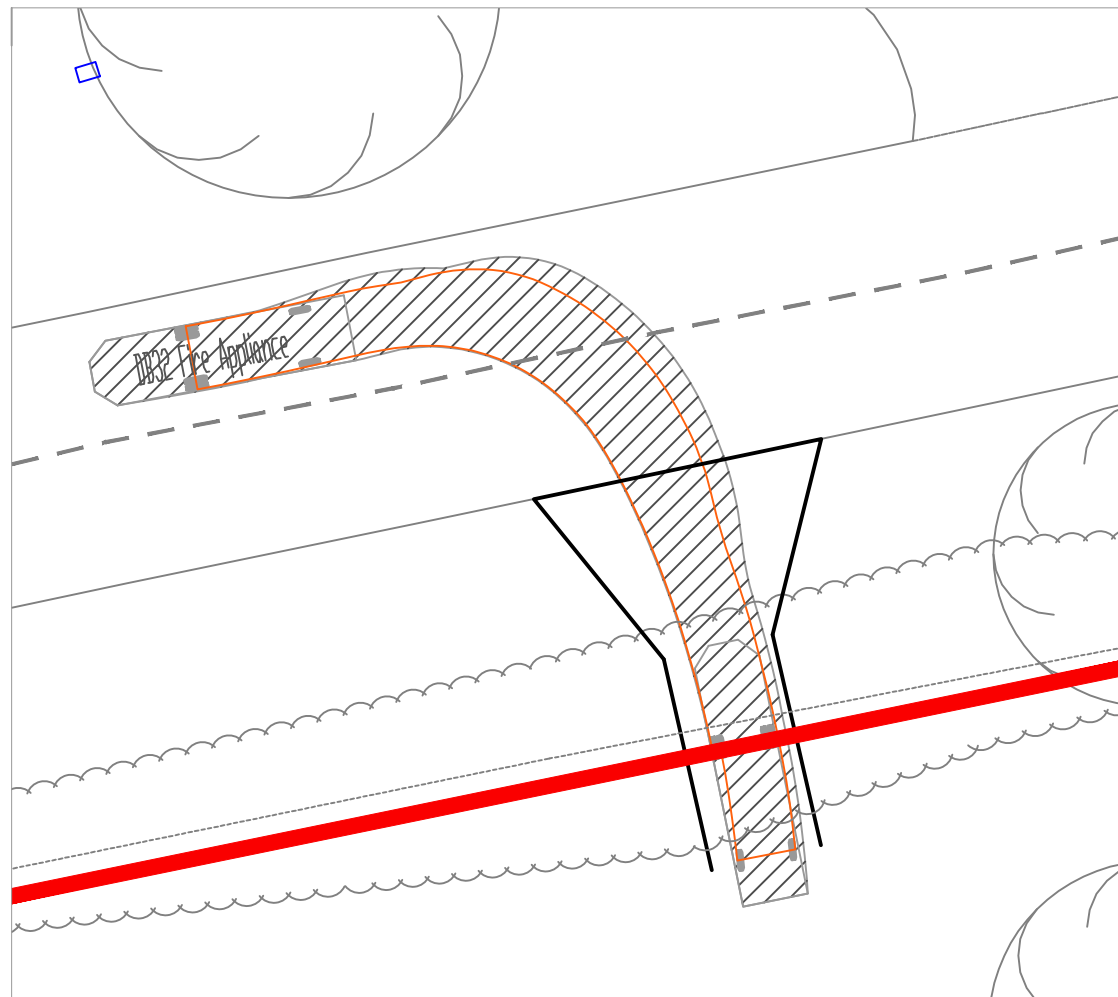

NOTE:

1. THIS DRAWING IS BASED UPON DRAWING NUMBER ME-24-2IQ BY DAVID WILSON HOMES (MERCIA).
2. THIS DRAWING IS BASED UPON THE ORDNANCE SURVEY'S (1:250) MAP WITH PERMISSION OF THE CONTROLLER OF HER MAJESTY'S STATIONERY OFFICE, CROWN COPYRIGHT RESERVED.
3. THIS DRAWING IS INDICATIVE AND SUBJECT TO DISCUSSIONS WITH LOCAL & NATIONAL HIGHWAY AUTHORITIES. THIS DESIGN IS ALSO SUBJECT TO CONFIRMATION OF LAND OWNERSHIP, TOPOGRAPHY, LOCATION OF STATUTORY SERVICES, DETAILED DESIGN AND TRAFFIC MODELLING.
4. ROAD MARKINGS & TRAFFIC SIGNS ARE TO BE IN ACCORDANCE WITH 'THE TRAFFIC SIGNS REGULATIONS AND GENERAL DIRECTIONS 2016'
5. DO NOT SCALE FROM THIS DRAWING WORK FROM FIGURED DIMENSIONS ONLY.
6. ALL DIMENSIONS ARE SHOWN IN METRES UNLESS NOTED OTHERWISE.

KEY:

— SITE BOUNDARY

VEHICLE PROFILE:

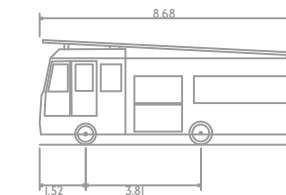

DB32 Fire Appliance	8.680m
Overall Length	2.180m
Overall Width	3.452m
Overall Body Height	0.337m
Min Body Ground Clearance	2.121m
Max Track Width	6.00s
Lock to lock time	7.910m
Kerb to Kerb Turning Radius	

REV	DATE	REMARKS
A	15.10.2021	REVISED LAYOUT
-	25.08.2021	INITIAL ISSUE

CLIENT

DAVID WILSON HOMES (MERCIA)

JOB TITLE

HITHER GREEN LANE, REDDITCH

DRAWING TITLE

EMERGENCY ACCESS - FIRE TENDER
SWEEP-PATH ANALYSIS

DRAWING NO.

J32-5756-PS-005

DRAWN
JN

CHECKED
JB / AS

CREATED
AUG' 21

SCALE
1:250 @A3

mode transport planning
LOMBARD HOUSE
145 GREAT CHARLES STREET
BIRMINGHAM
B3 3LP



T 0121 794 8390
E INFO@MODETRANSPORT.CO.UK
W WWW.MODETRANSPORT.CO.UK

transport planning

APPENDIX E

TRICS Search Outputs

TRIP RATE CALCULATION SELECTION PARAMETERS:

Land Use : 03 - RESIDENTIAL
 Category : A - HOUSES PRIVATELY OWNED

MULTI-MODAL TOTAL VEHICLESSelected regions and areas:

02 SOUTH EAST		
HF	HERTFORDSHIRE	1 days
KC	KENT	1 days
WS	WEST SUSSEX	1 days
04 EAST ANGLIA		
NF	NORFOLK	1 days
06 WEST MIDLANDS		
ST	STAFFORDSHIRE	1 days

This section displays the number of survey days per TRICS® sub-region in the selected set

Primary Filtering selection:

This data displays the chosen trip rate parameter and its selected range. Only sites that fall within the parameter range are included in the trip rate calculation.

Parameter: No of Dwellings
 Actual Range: 151 to 288 (units:)
 Range Selected by User: 150 to 350 (units:)

Parking Spaces Range: All Surveys Included

Parking Spaces per Dwelling Range: All Surveys Included

Bedrooms per Dwelling Range: All Surveys Included

Percentage of dwellings privately owned: All Surveys Included

Public Transport Provision:

Selection by: Include all surveys

Date Range: 01/01/13 to 23/09/19

This data displays the range of survey dates selected. Only surveys that were conducted within this date range are included in the trip rate calculation.

Selected survey days:

Monday	2 days
Wednesday	2 days
Thursday	1 days

This data displays the number of selected surveys by day of the week.

Selected survey types:

Manual count	5 days
Directional ATC Count	0 days

This data displays the number of manual classified surveys and the number of unclassified ATC surveys, the total adding up to the overall number of surveys in the selected set. Manual surveys are undertaken using staff, whilst ATC surveys are undertaken using machines.

Selected Locations:

Edge of Town	5
--------------	---

This data displays the number of surveys per main location category within the selected set. The main location categories consist of Free Standing, Edge of Town, Suburban Area, Neighbourhood Centre, Edge of Town Centre, Town Centre and Not Known.

Selected Location Sub Categories:

Residential Zone	5
------------------	---

This data displays the number of surveys per location sub-category within the selected set. The location sub-categories consist of Commercial Zone, Industrial Zone, Development Zone, Residential Zone, Retail Zone, Built-Up Zone, Village, Out of Town, High Street and No Sub Category.

Secondary Filtering selection:Use Class:

C3 5 days

This data displays the number of surveys per Use Class classification within the selected set. The Use Classes Order 2005 has been used for this purpose, which can be found within the Library module of TRICS®.

Population within 500m Range:

All Surveys Included

Population within 1 mile:

5,001 to 10,000 3 days

10,001 to 15,000 2 days

This data displays the number of selected surveys within stated 1-mile radii of population.

Population within 5 miles:

5,001 to 25,000 1 days

50,001 to 75,000 1 days

75,001 to 100,000 3 days

This data displays the number of selected surveys within stated 5-mile radii of population.

Car ownership within 5 miles:

0.6 to 1.0 1 days

1.1 to 1.5 3 days

1.6 to 2.0 1 days

This data displays the number of selected surveys within stated ranges of average cars owned per residential dwelling, within a radius of 5-miles of selected survey sites.

Travel Plan:

Yes 3 days

No 2 days

This data displays the number of surveys within the selected set that were undertaken at sites with Travel Plans in place, and the number of surveys that were undertaken at sites without Travel Plans.

PTAL Rating:

No PTAL Present 5 days

This data displays the number of selected surveys with PTAL Ratings.

LIST OF SITES relevant to selection parameters

1	HF-03-A-03	MIXED HOUSES	HERTFORDSHIRE
	HARE STREET ROAD BUNTINGFORD		
	Edge of Town Residential Zone		
	Total No of Dwellings:	160	
	Survey date: MONDAY	08/07/19	Survey Type: MANUAL
2	KC-03-A-07	MIXED HOUSES	KENT
	RECVLVER ROAD HERNE BAY		
	Edge of Town Residential Zone		
	Total No of Dwellings:	288	
	Survey date: WEDNESDAY	27/09/17	Survey Type: MANUAL
3	NF-03-A-06	MIXED HOUSES	NORFOLK
	BEAUFORT WAY GREAT YARMOUTH BRADWELL		
	Edge of Town Residential Zone		
	Total No of Dwellings:	275	
	Survey date: MONDAY	23/09/19	Survey Type: MANUAL
4	ST-03-A-07	DETACHED & SEMI-DETACHED	STAFFORDSHIRE
	BEACONSIDE STAFFORD MARSTON GATE		
	Edge of Town Residential Zone		
	Total No of Dwellings:	248	
	Survey date: WEDNESDAY	22/11/17	Survey Type: MANUAL
5	WS-03-A-04	MIXED HOUSES	WEST SUSSEX
	HILLS FARM LANE HORSHAM BROADBRIDGE HEATH		
	Edge of Town Residential Zone		
	Total No of Dwellings:	151	
	Survey date: THURSDAY	11/12/14	Survey Type: MANUAL

This section provides a list of all survey sites and days in the selected set. For each individual survey site, it displays a unique site reference code and site address, the selected trip rate calculation parameter and its value, the day of the week and date of each survey, and whether the survey was a manual classified count or an ATC count.

TRIP RATE for Land Use 03 - RESIDENTIAL/A - HOUSES PRIVATELY OWNED

MULTI-MODAL TOTAL VEHICLES**Calculation factor: 1 DWELLS****BOLD print indicates peak (busiest) period**

Time Range	ARRIVALS			DEPARTURES			TOTALS		
	No. Days	Ave. DWELLS	Trip Rate	No. Days	Ave. DWELLS	Trip Rate	No. Days	Ave. DWELLS	Trip Rate
00:00 - 01:00									
01:00 - 02:00									
02:00 - 03:00									
03:00 - 04:00									
04:00 - 05:00									
05:00 - 06:00									
06:00 - 07:00									
07:00 - 08:00	5	224	0.112	5	224	0.316	5	224	0.428
08:00 - 09:00	5	224	0.171	5	224	0.402	5	224	0.573
09:00 - 10:00	5	224	0.143	5	224	0.176	5	224	0.319
10:00 - 11:00	5	224	0.114	5	224	0.151	5	224	0.265
11:00 - 12:00	5	224	0.119	5	224	0.147	5	224	0.266
12:00 - 13:00	5	224	0.163	5	224	0.147	5	224	0.310
13:00 - 14:00	5	224	0.168	5	224	0.143	5	224	0.311
14:00 - 15:00	5	224	0.191	5	224	0.199	5	224	0.390
15:00 - 16:00	5	224	0.299	5	224	0.188	5	224	0.487
16:00 - 17:00	5	224	0.299	5	224	0.178	5	224	0.477
17:00 - 18:00	5	224	0.367	5	224	0.160	5	224	0.527
18:00 - 19:00	5	224	0.298	5	224	0.207	5	224	0.505
19:00 - 20:00									
20:00 - 21:00									
21:00 - 22:00									
22:00 - 23:00									
23:00 - 24:00									
Total Rates:			2.444			2.414			4.858

This section displays the trip rate results based on the selected set of surveys and the selected count type (shown just above the table). It is split by three main columns, representing arrivals trips, departures trips, and total trips (arrivals plus departures). Within each of these main columns are three sub-columns. These display the number of survey days where count data is included (per time period), the average value of the selected trip rate calculation parameter (per time period), and the trip rate result (per time period). Total trip rates (the sum of the column) are also displayed at the foot of the table.

To obtain a trip rate, the average (mean) trip rate parameter value (TRP) is first calculated for all selected survey days that have count data available for the stated time period. The average (mean) number of arrivals, departures or totals (whichever applies) is also calculated (COUNT) for all selected survey days that have count data available for the stated time period. Then, the average count is divided by the average trip rate parameter value, and multiplied by the stated calculation factor (shown just above the table and abbreviated here as FACT). So, the method is: COUNT/TRP*FACT. Trip rates are then rounded to 3 decimal places.

The survey data, graphs and all associated supporting information, contained within the TRICS Database are published by TRICS Consortium Limited ("the Company") and the Company claims copyright and database rights in this published work. The Company authorises those who possess a current TRICS licence to access the TRICS Database and copy the data contained within the TRICS Database for the licence holders' use only. Any resulting copy must retain all copyrights and other proprietary notices, and any disclaimer contained thereon.

The Company accepts no responsibility for loss which may arise from reliance on data contained in the TRICS Database. [No warranty of any kind, express or implied, is made as to the data contained in the TRICS Database.]

Parameter summary

Trip rate parameter range selected: 151 - 288 (units:)
Survey date range: 01/01/13 - 23/09/19
Number of weekdays (Monday-Friday): 5
Number of Saturdays: 0
Number of Sundays: 0
Surveys automatically removed from selection: 0
Surveys manually removed from selection: 0

This section displays a quick summary of some of the data filtering selections made by the TRICS® user. The trip rate calculation parameter range of all selected surveys is displayed first, followed by the range of minimum and maximum survey dates selected by the user. Then, the total number of selected weekdays and weekend days in the selected set of surveys are shown. Finally, the number of survey days that have been manually removed from the selected set outside of the standard filtering procedure are displayed.

APPENDIX F

Traffic Flow Diagrams

Figure F.1
Title - 2030 Effective Base AM

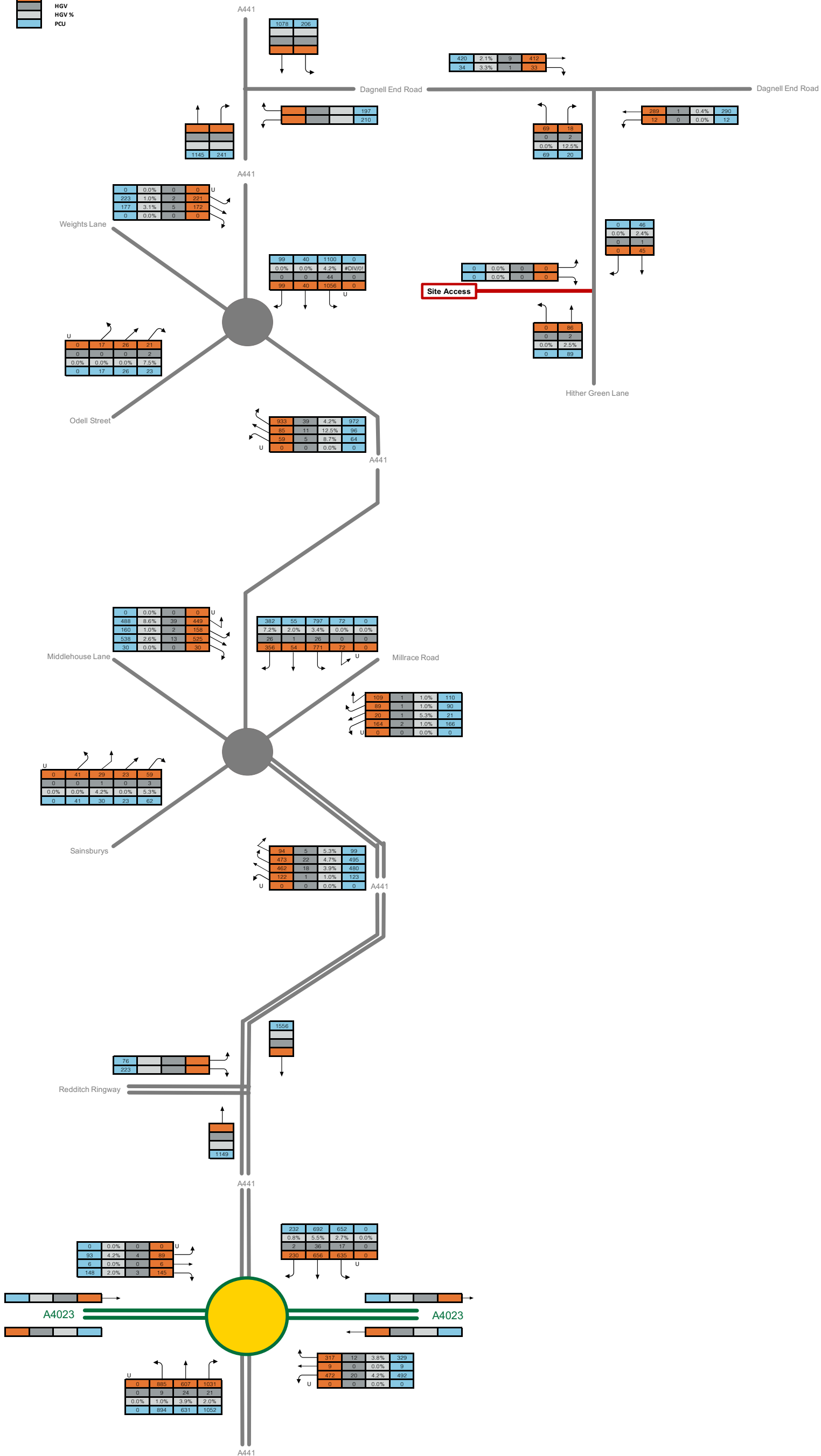
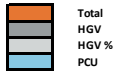

Figure F.2
Title - 2030 Effective Base PM

Total
HGVS
HGVS %
PCU

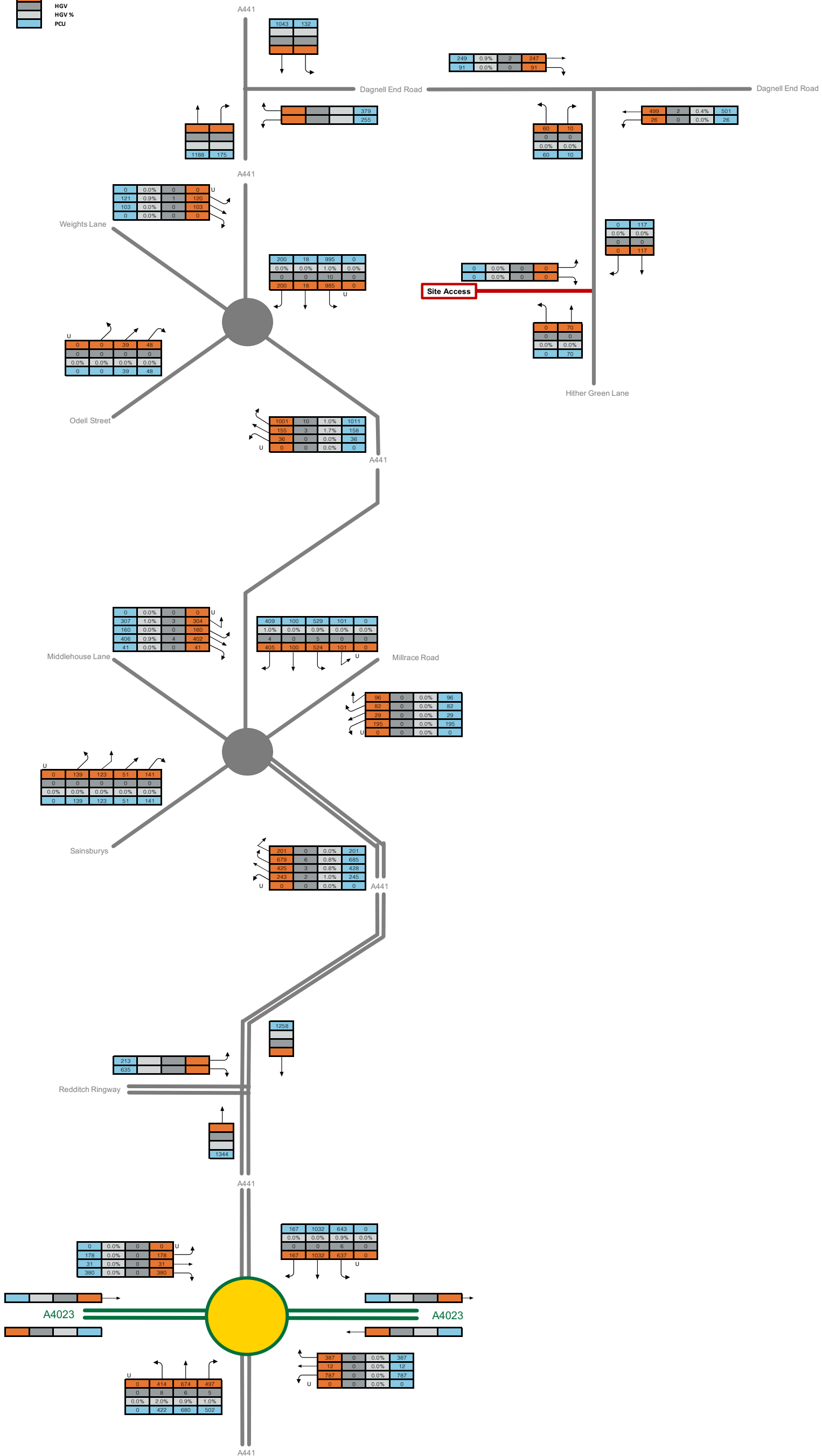

Figure F.3
Title - 2030 Effective Base + Development AM

Total
HGVT
HGVT %
PCU

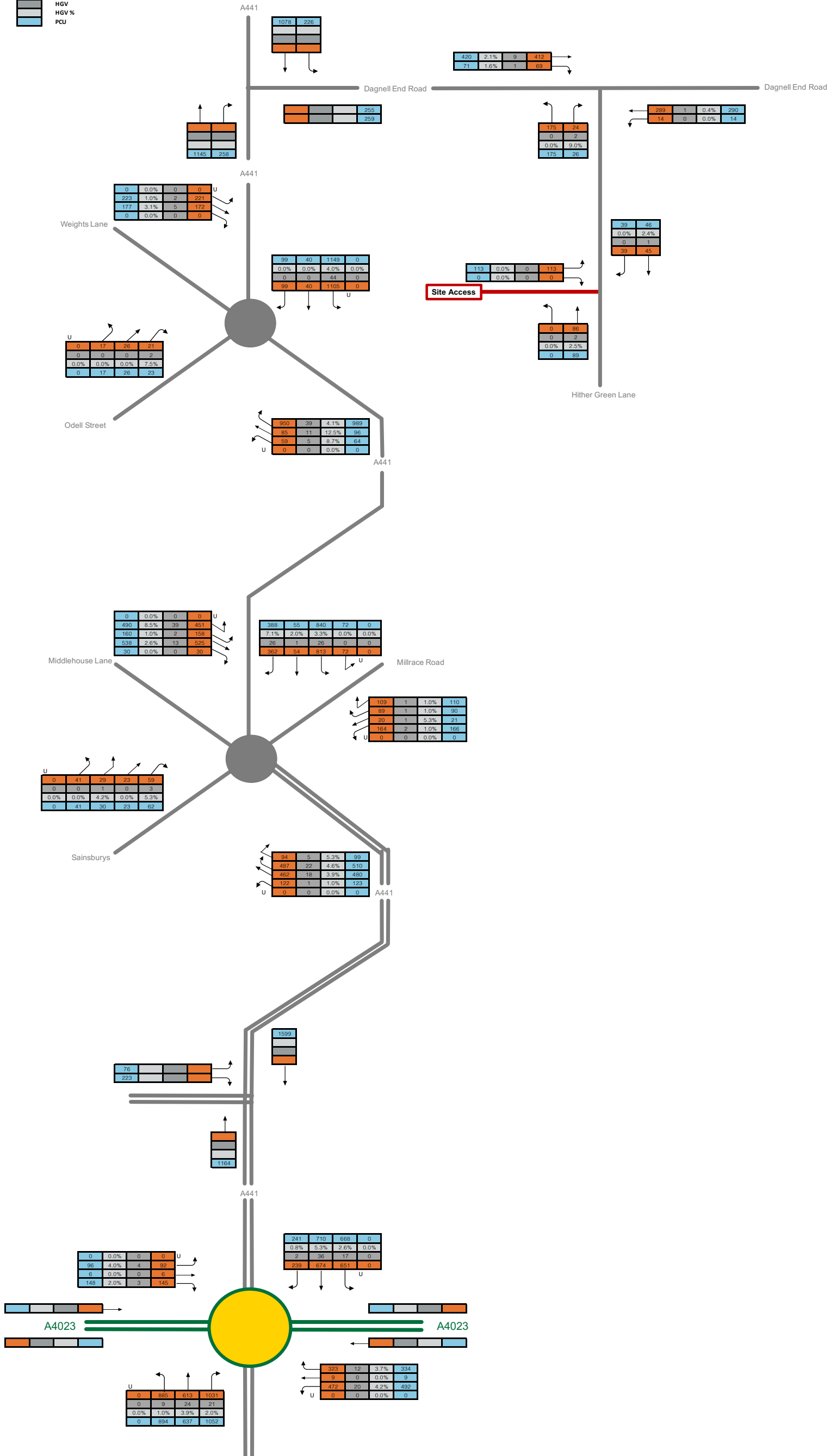
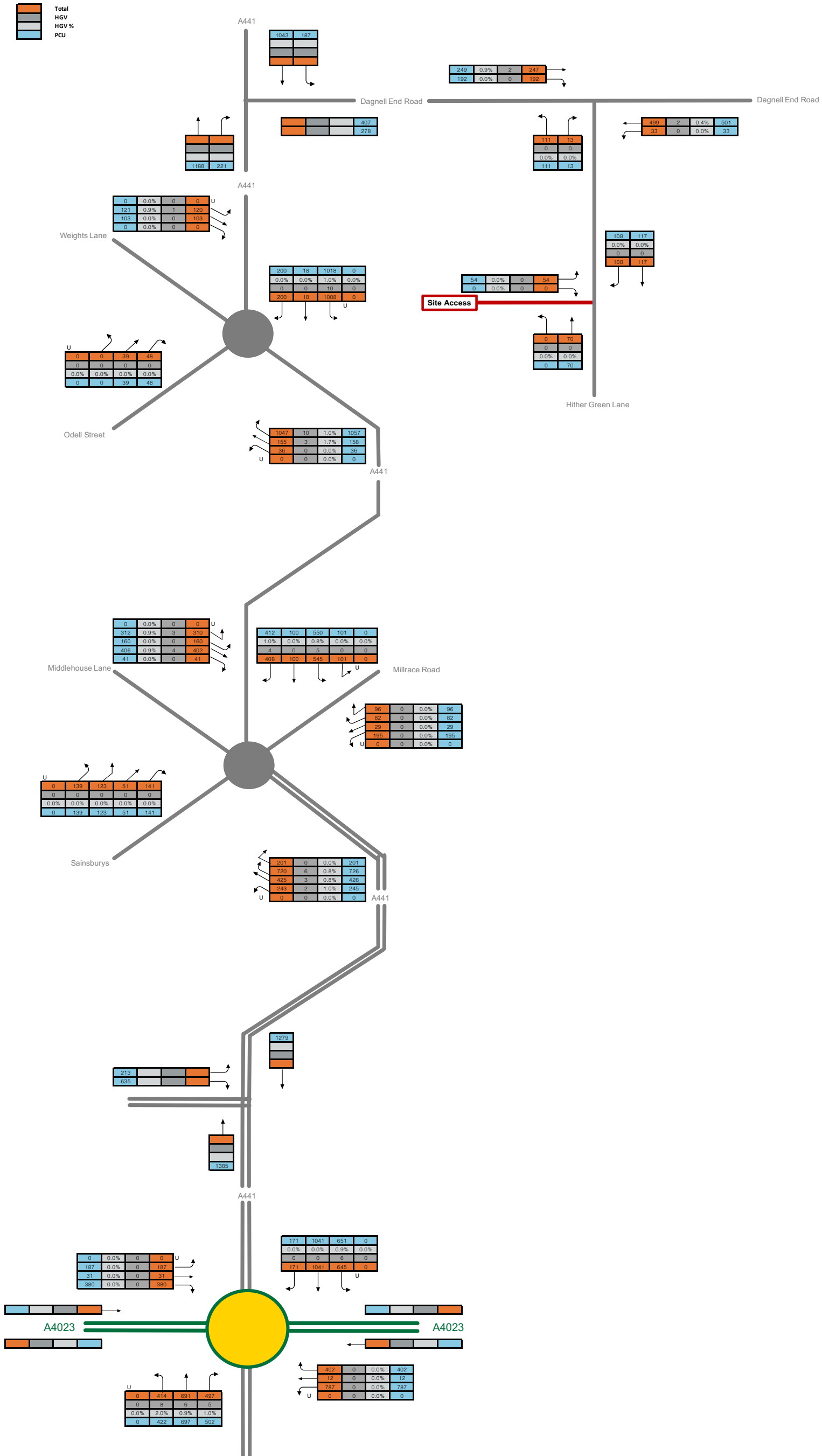

Figure F.4
Title - 2030 Effective Base + Development PM



APPENDIX G

Junction Capacity Assessment Outputs

Junctions 9
PICADY 9 - Priority Intersection Module
Version: 9.5.0.6896 © Copyright TRL Limited, 2018
For sales and distribution information, program advice and maintenance, contact TRL: +44 (0)1344 379777 software@trl.co.uk www.trlsoftware.co.uk
The users of this computer program for the solution of an engineering problem are in no way relieved of their responsibility for the correctness of the solution

Filename: 1 (V2) Site Access - Hither Green.j9
Path: C:\Users\JamesMonk\Dropbox (mode)\Project\Birmingham\2. Projects\J325756_Hither Green Lane, Redditch\4. Data\Junction assessment\Historical application
Report generation date: 25/08/2021 16:46:40

- «2030 Base + Dev, AM
 - »Junction Network
 - »Arms
 - »Traffic Demand
 - »Origin-Destination Data
 - »Vehicle Mix
 - »Results

Summary of junction performance

	AM				PM			
	Queue (PCU)	Delay (s)	RFC	LOS	Queue (PCU)	Delay (s)	RFC	LOS
2030 Base + Dev								
Stream B-CD	0.0	0.00	0.00	A	0.0	0.00	0.00	A
Stream B-AD	0.0	0.00	0.00	A	0.0	0.00	0.00	A
Stream A-BCD	0.1	6.40	0.08	A	0.3	6.94	0.22	A
Stream D-AB	0.2	6.84	0.19	A	0.1	6.04	0.09	A
Stream D-BC	0.0	0.00	0.00	A	0.0	0.00	0.00	A
Stream C-ABD	0.0	0.00	0.00	A	0.0	0.00	0.00	A

There are warnings associated with one or more model runs - see the 'Data Errors and Warnings' tables for each Analysis or Demand Set.

Values shown are the highest values encountered over all time segments. Delay is the maximum value of average delay per arriving vehicle.

File summary

File Description

Title	
Location	
Site number	
Date	25/08/2021
Version	
Status	(new file)
Identifier	
Client	
Jobnumber	
Enumerator	AzureAD\JamesMonk
Description	

Units

Distance units	Speed units	Traffic units input	Traffic units results	Flow units	Average delay units	Total delay units	Rate of delay units
m	kph	PCU	PCU	perHour	s	-Min	perMin

Analysis Options

Calculate Queue Percentiles	Calculate residual capacity	RFC Threshold	Average Delay threshold (s)	Queue threshold (PCU)
		0.85	36.00	20.00

Analysis Set Details

ID	Network flow scaling factor (%)
A1	100.000

Demand Set Details

ID	Scenario name	Time Period name	Traffic profile type	Start time (HH:mm)	Finish time (HH:mm)	Time segment length (min)
D3	2030 Base + Dev	AM	ONE HOUR	07:45	09:15	15

2030 Base + Dev, AM

Data Errors and Warnings

Severity	Area	Item	Description
Warning	Major arm width	A - Hither Green Lane N - Major arm geometry	For two-way major roads, please interpret results with caution if the total major carriageway width is less than 6m.
Warning	Major arm width	C - Hither Green Lane S - Major arm geometry	For two-way major roads, please interpret results with caution if the total major carriageway width is less than 6m.
Warning	Vehicle Mix		HV% is zero for all movements / time segments. Vehicle Mix matrix should be completed whether working in PCUs or Vehs. If HV% at the junction is genuinely zero, please ignore this warning.

Junction Network

Junctions

Junction	Name	Junction type	Major road direction	Use circulating lanes	Junction Delay (s)	Junction LOS
1	untitled	Crossroads	Two-way		3.68	A

Junction Network Options

Driving side	Lighting
Left	Normal/unknown

Arms

Arms

Arm	Name	Description	Arm type
A	Hither Green Lane N		Major
B	Unnamed Access Road		Minor
C	Hither Green Lane S		Major
D	Site Access		Minor

Major Arm Geometry

Arm	Width of carriageway (m)	Has kerbed central reserve	Has right turn bay	Visibility for right turn (m)	Blocks?	Blocking queue (PCU)
A - Hither Green Lane N	5.50			41.0	✓	0.00
C - Hither Green Lane S	5.50			93.4	✓	0.00

Geometries for Arm C are measured opposite Arm B. Geometries for Arm A (if relevant) are measured opposite Arm D.

Minor Arm Geometry

Arm	Minor arm type	Width at give-way (m)	Width at 5m (m)	Width at 10m (m)	Width at 15m (m)	Width at 20m (m)	Estimate flare length	Flare length (PCU)	Visibility to left (m)	Visibility to right (m)
B - Unnamed Access Road	One lane plus flare	10.00	4.00	2.50	2.20	2.20		1.00	19	17
D - Site Access	One lane plus flare	10.00	4.80	2.75	2.75	2.75		1.00	22	21

Slope / Intercept / Capacity

Priority Intersection Slopes and Intercepts

Junction	Stream	Intercept (PCU/hr)	Slope for A-B	Slope for A-C	Slope for A-D	Slope for B-A	Slope for B-C	Slope for B-D	Slope for C-A	Slope for C-B	Slope for C-D	Slope for D-A	Slope for D-B	Slope for D-C
1	A-D	598	-	-	-	-	-	-	0.237	0.338	0.237	-	-	-
1	B-A	501	0.093	0.236	0.236	-	-	-	0.148	0.337	-	0.236	0.236	0.118
1	B-C	762	0.119	0.302	-	-	-	-	-	-	-	-	-	-
1	B-D, nearside lane	591	0.110	0.278	0.278	-	-	-	0.175	0.397	0.175	-	-	-
1	B-D, offside lane	501	0.093	0.236	0.236	-	-	-	0.148	0.337	0.148	-	-	-
1	C-B	628	0.249	0.249	0.355	-	-	-	-	-	-	-	-	-
1	D-A	676	-	-	-	-	-	-	0.268	-	0.106	-	-	-
1	D-B, nearside lane	525	0.155	0.155	0.353	-	-	-	0.247	0.247	0.098	-	-	-
1	D-B, offside lane	470	0.139	0.139	0.316	-	-	-	0.221	0.221	0.088	-	-	-
1	D-C	470	-	0.139	0.316	0.111	0.221	0.221	0.221	0.221	0.088	-	-	-

The slopes and intercepts shown above do NOT include any corrections or adjustments.

Streams may be combined, in which case capacity will be adjusted.

Values are shown for the first time segment only; they may differ for subsequent time segments.

Traffic Demand

Vehicle mix source	PCU Factor for a HV (PCU)
HV Percentages	2.00

Demand overview (Traffic)

Arm	Linked arm	Use O-D data	Average Demand (PCU/hr)	Scaling Factor (%)
A - Hither Green Lane N		✓	84	100.000
B - Unnamed Access Road		✓	0	100.000
C - Hither Green Lane S		✓	86	100.000
D - Site Access		✓	113	100.000

Origin-Destination Data

Demand (PCU/hr)

		To			
		A - Hither Green Lane N	B - Unnamed Access Road	C - Hither Green Lane S	D - Site Access
From	A - Hither Green Lane N	0	0	45	39
	B - Unnamed Access Road	0	0	0	0
	C - Hither Green Lane S	86	0	0	0
	D - Site Access	113	0	0	0

Vehicle Mix

Heavy Vehicle Percentages

		To			
		A - Hither Green Lane N	B - Unnamed Access Road	C - Hither Green Lane S	D - Site Access
From	A - Hither Green Lane N	0	0	0	0
	B - Unnamed Access Road	0	0	0	0
	C - Hither Green Lane S	0	0	0	0
	D - Site Access	0	0	0	0

Results

Results Summary for whole modelled period

Stream	Max RFC	Max Delay (s)	Max Queue (PCU)	Max LOS
B-CD	0.00	0.00	0.0	A
B-AD	0.00	0.00	0.0	A
A-BCD	0.08	6.40	0.1	A
A-B				
A-C				
D-AB	0.19	6.84	0.2	A
D-BC	0.00	0.00	0.0	A
C-ABD	0.00	0.00	0.0	A
C-D				
C-A				

Main Results for each time segment

07:45 - 08:00

Stream	Total Demand (PCU/hr)	Capacity (PCU/hr)	RFC	Throughput (PCU/hr)	End queue (PCU)	Delay (s)	Unsignalised level of service
B-CD	0	643	0.000	0	0.0	0.000	A
B-AD	0	466	0.000	0	0.0	0.000	A
A-BCD	31	605	0.051	31	0.1	6.266	A
A-B	0			0			
A-C	32			32			
D-AB	85	659	0.129	84	0.1	6.261	A
D-BC	0	442	0.000	0	0.0	0.000	A
C-ABD	0	609	0.000	0	0.0	0.000	A
C-D	0			0			
C-A	65			65			

08:00 - 08:15

Stream	Total Demand (PCU/hr)	Capacity (PCU/hr)	RFC	Throughput (PCU/hr)	End queue (PCU)	Delay (s)	Unsignalised level of service
B-CD	0	638	0.000	0	0.0	0.000	A
B-AD	0	459	0.000	0	0.0	0.000	A
A-BCD	38	607	0.062	38	0.1	6.323	A
A-B	0			0			
A-C	38			38			
D-AB	102	655	0.155	101	0.2	6.496	A
D-BC	0	436	0.000	0	0.0	0.000	A
C-ABD	0	605	0.000	0	0.0	0.000	A
C-D	0			0			
C-A	77			77			

08:15 - 08:30

Stream	Total Demand (PCU/hr)	Capacity (PCU/hr)	RFC	Throughput (PCU/hr)	End queue (PCU)	Delay (s)	Unsignalised level of service
B-CD	0	632	0.000	0	0.0	0.000	A
B-AD	0	450	0.000	0	0.0	0.000	A
A-BCD	47	609	0.077	47	0.1	6.401	A
A-B	0			0			
A-C	46			46			
D-AB	124	651	0.191	124	0.2	6.833	A
D-BC	0	429	0.000	0	0.0	0.000	A
C-ABD	0	600	0.000	0	0.0	0.000	A
C-D	0			0			
C-A	95			95			

08:30 - 08:45

Stream	Total Demand (PCU/hr)	Capacity (PCU/hr)	RFC	Throughput (PCU/hr)	End queue (PCU)	Delay (s)	Unsignalised level of service
B-CD	0	632	0.000	0	0.0	0.000	A
B-AD	0	450	0.000	0	0.0	0.000	A
A-BCD	47	609	0.077	47	0.1	6.402	A
A-B	0			0			
A-C	46			46			
D-AB	124	651	0.191	124	0.2	6.838	A
D-BC	0	429	0.000	0	0.0	0.000	A
C-ABD	0	600	0.000	0	0.0	0.000	A
C-D	0			0			
C-A	95			95			

08:45 - 09:00

Stream	Total Demand (PCU/hr)	Capacity (PCU/hr)	RFC	Throughput (PCU/hr)	End queue (PCU)	Delay (s)	Unsignalised level of service
B-CD	0	638	0.000	0	0.0	0.000	A
B-AD	0	459	0.000	0	0.0	0.000	A
A-BCD	38	607	0.062	38	0.1	6.325	A
A-B	0			0			
A-C	38			38			
D-AB	102	655	0.155	102	0.2	6.503	A
D-BC	0	436	0.000	0	0.0	0.000	A
C-ABD	0	605	0.000	0	0.0	0.000	A
C-D	0			0			
C-A	77			77			

09:00 - 09:15

Stream	Total Demand (PCU/hr)	Capacity (PCU/hr)	RFC	Throughput (PCU/hr)	End queue (PCU)	Delay (s)	Unsignalised level of service
B-CD	0	643	0.000	0	0.0	0.000	A
B-AD	0	466	0.000	0	0.0	0.000	A
A-BCD	31	605	0.051	31	0.1	6.270	A
A-B	0			0			
A-C	32			32			
D-AB	85	659	0.129	85	0.1	6.277	A
D-BC	0	442	0.000	0	0.0	0.000	A
C-ABD	0	609	0.000	0	0.0	0.000	A
C-D	0			0			
C-A	65			65			

Junctions 9
PICADY 9 - Priority Intersection Module
Version: 9.5.0.6896 © Copyright TRL Limited, 2018
For sales and distribution information, program advice and maintenance, contact TRL: +44 (0)1344 379777 software@trl.co.uk www.trlsoftware.co.uk
The users of this computer program for the solution of an engineering problem are in no way relieved of their responsibility for the correctness of the solution

Filename: 2 - Hither Green Lane - Dagnell End Road.j9

Path: C:\Users\JamesMonk\Dropbox (mode)\Project\Birmingham\2. Projects\J325756_Hither Green Lane, Redditch\4.

Data\Junction assessment\Historical application

Report generation date: 05/08/2021 12:01:25

- »2030 Base, AM
- »2030 Base, PM
- »2030 Base + Dev, AM
- »2030 Base + Dev, PM

Summary of junction performance

	AM				PM			
	Queue (Veh)	Delay (s)	RFC	LOS	Queue (Veh)	Delay (s)	RFC	LOS
2030 Base								
Stream B-C	0.2	7.50	0.14	A	0.2	8.22	0.13	A
Stream B-A	0.1	10.65	0.06	B	0.0	10.59	0.03	B
Stream C-AB	0.1	4.52	0.08	A	0.4	6.06	0.21	A
2030 Base + Dev								
Stream B-C	0.5	10.01	0.35	B	0.3	9.50	0.24	A
Stream B-A	0.1	11.39	0.08	B	0.0	12.32	0.05	B
Stream C-AB	0.4	4.73	0.17	A	1.1	8.65	0.44	A

There are warnings associated with one or more model runs - see the 'Data Errors and Warnings' tables for each Analysis or Demand Set.

Values shown are the highest values encountered over all time segments. Delay is the maximum value of average delay per arriving vehicle.

File summary

File Description

Title	
Location	
Site number	
Date	28/07/2021
Version	
Status	(new file)
Identifier	
Client	
Jobnumber	
Enumerator	AzureAD\JamesMonk
Description	

Units

Distance units	Speed units	Traffic units input	Traffic units results	Flow units	Average delay units	Total delay units	Rate of delay units
m	kph	Veh	Veh	perHour	s	-Min	perMin

Analysis Options

Calculate Queue Percentiles	Calculate residual capacity	RFC Threshold	Average Delay threshold (s)	Queue threshold (PCU)
		0.85	36.00	20.00

Demand Set Summary

ID	Scenario name	Time Period name	Traffic profile type	Start time (HH:mm)	Finish time (HH:mm)	Time segment length (min)
D1	2030 Base	AM	ONE HOUR	07:45	09:15	15
D2	2030 Base	PM	ONE HOUR	16:45	18:15	15
D3	2030 Base + Dev	AM	ONE HOUR	07:45	09:15	15
D4	2030 Base + Dev	PM	ONE HOUR	16:45	18:15	15

Analysis Set Details

ID	Network flow scaling factor (%)
A1	100.000

2030 Base, AM

Data Errors and Warnings

Severity	Area	Item	Description
Warning	Minor arm flare	B - Hither Green Lane (Western Side) - Minor arm geometry	Is flare very short? Estimated flare length is zero but has been increased to 1 because a zero flare length is not allowed.

Junction Network

Junctions

Junction	Name	Junction type	Major road direction	Use circulating lanes	Junction Delay (s)	Junction LOS
1	untitled	T-Junction	Two-way		1.19	A

Junction Network Options

Driving side	Lighting
Left	Normal/unknown

Arms

Arms

Arm	Name	Description	Arm type
A	Dagnell End Road East		Major
B	Hither Green Lane (Western Side)		Minor
C	Dagnell End Road West		Major

Major Arm Geometry

Arm	Width of carriageway (m)	Has kerbed central reserve	Has right turn bay	Visibility for right turn (m)	Blocks?	Blocking queue (PCU)
C - Dagnell End Road West	7.30			250.0	✓	0.00

Geometries for Arm C are measured opposite Arm B. Geometries for Arm A (if relevant) are measured opposite Arm D.

Minor Arm Geometry

Arm	Minor arm type	Width at give-way (m)	Width at 5m (m)	Width at 10m (m)	Width at 15m (m)	Width at 20m (m)	Estimate flare length	Flare length (PCU)	Visibility to left (m)	Visibility to right (m)
B - Hither Green Lane (Western Side)	One lane plus flare	9.48	3.42	2.23	2.23	2.23	✓	1.00	21	23

Slope / Intercept / Capacity

Priority Intersection Slopes and Intercepts

Junction	Stream	Intercept (Veh/hr)	Slope for A-B	Slope for A-C	Slope for C-A	Slope for C-B
1	B-A	569	0.098	0.247	0.156	0.353
1	B-C	640	0.093	0.234	-	-
1	C-B	719	0.263	0.263	-	-

The slopes and intercepts shown above do NOT include any corrections or adjustments.

Streams may be combined, in which case capacity will be adjusted.

Values are shown for the first time segment only; they may differ for subsequent time segments.

Traffic Demand

Demand Set Details

ID	Scenario name	Time Period name	Traffic profile type	Start time (HH:mm)	Finish time (HH:mm)	Time segment length (min)
D1	2030 Base	AM	ONE HOUR	07:45	09:15	15

Vehicle mix source	PCU Factor for a HV (PCU)
HV Percentages	2.00

Demand overview (Traffic)

Arm	Linked arm	Use O-D data	Average Demand (Veh/hr)	Scaling Factor (%)
A - Dagnell End Road East		✓	301	100.000
B - Hither Green Lane (Western Side)		✓	87	100.000
C - Dagnell End Road West		✓	445	100.000

Origin-Destination Data

Demand (Veh/hr)

From	To		
	A - Dagnell End Road East	B - Hither Green Lane (Western Side)	C - Dagnell End Road West
A - Dagnell End Road East	0	12	289
B - Hither Green Lane (Western Side)	18	0	69
C - Dagnell End Road West	412	33	0

Vehicle Mix

Heavy Vehicle Percentages

From	To		
	A - Dagnell End Road East	B - Hither Green Lane (Western Side)	C - Dagnell End Road West
A - Dagnell End Road East	0	0	0
B - Hither Green Lane (Western Side)	13	0	0
C - Dagnell End Road West	2	3	0

Results

Results Summary for whole modelled period

Stream	Max RFC	Max Delay (s)	Max Queue (Veh)	Max LOS
B-C	0.14	7.50	0.2	A
B-A	0.06	10.65	0.1	B
C-AB	0.08	4.52	0.1	A
C-A				
A-B				
A-C				

Main Results for each time segment

07:45 - 08:00

Stream	Total Demand (Veh/hr)	Capacity (Veh/hr)	RFC	Throughput (Veh/hr)	End queue (Veh)	Delay (s)	Unsignalised level of service
B-C	52	583	0.089	52	0.1	6.771	A
B-A	14	405	0.033	13	0.0	9.189	A
C-AB	40	836	0.047	39	0.1	4.518	A
C-A	296			296			
A-B	9			9			
A-C	218			218			

08:00 - 08:15

Stream	Total Demand (Veh/hr)	Capacity (Veh/hr)	RFC	Throughput (Veh/hr)	End queue (Veh)	Delay (s)	Unsignalised level of service
B-C	62	572	0.109	62	0.1	7.063	A
B-A	16	385	0.042	16	0.0	9.751	A
C-AB	52	865	0.060	52	0.1	4.426	A
C-A	348			348			
A-B	11			11			
A-C	260			260			

08:15 - 08:30

Stream	Total Demand (Veh/hr)	Capacity (Veh/hr)	RFC	Throughput (Veh/hr)	End queue (Veh)	Delay (s)	Unsignalised level of service
B-C	76	556	0.137	76	0.2	7.498	A
B-A	20	358	0.055	20	0.1	10.647	B
C-AB	73	908	0.080	73	0.1	4.314	A
C-A	417			417			
A-B	13			13			
A-C	318			318			

08:30 - 08:45

Stream	Total Demand (Veh/hr)	Capacity (Veh/hr)	RFC	Throughput (Veh/hr)	End queue (Veh)	Delay (s)	Unsignalised level of service
B-C	76	556	0.137	76	0.2	7.501	A
B-A	20	358	0.055	20	0.1	10.651	B
C-AB	73	908	0.080	73	0.1	4.316	A
C-A	417			417			
A-B	13			13			
A-C	318			318			

08:45 - 09:00

Stream	Total Demand (Veh/hr)	Capacity (Veh/hr)	RFC	Throughput (Veh/hr)	End queue (Veh)	Delay (s)	Unsignalised level of service
B-C	62	572	0.109	62	0.1	7.071	A
B-A	16	385	0.042	16	0.0	9.758	A
C-AB	52	866	0.060	52	0.1	4.427	A
C-A	348			348			
A-B	11			11			
A-C	260			260			

09:00 - 09:15

Stream	Total Demand (Veh/hr)	Capacity (Veh/hr)	RFC	Throughput (Veh/hr)	End queue (Veh)	Delay (s)	Unsignalised level of service
B-C	52	583	0.089	52	0.1	6.785	A
B-A	14	405	0.033	14	0.0	9.201	A
C-AB	40	836	0.047	40	0.1	4.522	A
C-A	295			295			
A-B	9			9			
A-C	218			218			

2030 Base, PM

Data Errors and Warnings

Severity	Area	Item	Description
Warning	Minor arm flare	B - Hither Green Lane (Western Side) - Minor arm geometry	Is flare very short? Estimated flare length is zero but has been increased to 1 because a zero flare length is not allowed.

Junction Network

Junctions

Junction	Name	Junction type	Major road direction	Use circulating lanes	Junction Delay (s)	Junction LOS
1	untitled	T-Junction	Two-way		1.50	A

Junction Network Options

Driving side	Lighting
Left	Normal/unknown

Traffic Demand

Demand Set Details

ID	Scenario name	Time Period name	Traffic profile type	Start time (HH:mm)	Finish time (HH:mm)	Time segment length (min)
D2	2030 Base	PM	ONE HOUR	16:45	18:15	15

Vehicle mix source	PCU Factor for a HV (PCU)
HV Percentages	2.00

Demand overview (Traffic)

Arm	Linked arm	Use O-D data	Average Demand (Veh/hr)	Scaling Factor (%)
A - Dagnell End Road East		✓	525	100.000
B - Hither Green Lane (Western Side)		✓	70	100.000
C - Dagnell End Road West		✓	338	100.000

Origin-Destination Data

Demand (Veh/hr)

		To		
		A - Dagnell End Road East	B - Hither Green Lane (Western Side)	C - Dagnell End Road West
From	A - Dagnell End Road East	0	26	499
	B - Hither Green Lane (Western Side)	10	0	60
	C - Dagnell End Road West	247	91	0

Vehicle Mix

Heavy Vehicle Percentages

		To		
		A - Dagnell End Road East	B - Hither Green Lane (Western Side)	C - Dagnell End Road West
From	A - Dagnell End Road East	0	0	0
	B - Hither Green Lane (Western Side)	0	0	0
	C - Dagnell End Road West	1	0	0

Results

Results Summary for whole modelled period

Stream	Max RFC	Max Delay (s)	Max Queue (Veh)	Max LOS
B-C	0.13	8.22	0.2	A
B-A	0.03	10.59	0.0	B
C-AB	0.21	6.06	0.4	A
C-A				
A-B				
A-C				

Main Results for each time segment

16:45 - 17:00

Stream	Total Demand (Veh/hr)	Capacity (Veh/hr)	RFC	Throughput (Veh/hr)	End queue (Veh)	Delay (s)	Unsignalised level of service
B-C	45	547	0.083	45	0.1	7.159	A
B-A	8	420	0.018	7	0.0	8.716	A
C-AB	92	736	0.124	91	0.2	5.574	A
C-A	163			163			
A-B	20			20			
A-C	376			376			

17:00 - 17:15

Stream	Total Demand (Veh/hr)	Capacity (Veh/hr)	RFC	Throughput (Veh/hr)	End queue (Veh)	Delay (s)	Unsignalised level of service
B-C	54	529	0.102	54	0.1	7.570	A
B-A	9	391	0.023	9	0.0	9.418	A
C-AB	117	742	0.158	117	0.3	5.755	A
C-A	187			187			
A-B	23			23			
A-C	449			449			

17:15 - 17:30

Stream	Total Demand (Veh/hr)	Capacity (Veh/hr)	RFC	Throughput (Veh/hr)	End queue (Veh)	Delay (s)	Unsignalised level of service
B-C	66	504	0.131	66	0.1	8.213	A
B-A	11	351	0.031	11	0.0	10.588	B
C-AB	157	752	0.209	157	0.4	6.050	A
C-A	215			215			
A-B	29			29			
A-C	549			549			

17:30 - 17:45

Stream	Total Demand (Veh/hr)	Capacity (Veh/hr)	RFC	Throughput (Veh/hr)	End queue (Veh)	Delay (s)	Unsignalised level of service
B-C	66	504	0.131	66	0.2	8.218	A
B-A	11	351	0.031	11	0.0	10.594	B
C-AB	158	752	0.209	158	0.4	6.061	A
C-A	215			215			
A-B	29			29			
A-C	549			549			

17:45 - 18:00

Stream	Total Demand (Veh/hr)	Capacity (Veh/hr)	RFC	Throughput (Veh/hr)	End queue (Veh)	Delay (s)	Unsignalised level of service
B-C	54	529	0.102	54	0.1	7.581	A
B-A	9	391	0.023	9	0.0	9.425	A
C-AB	117	743	0.158	118	0.3	5.773	A
C-A	187			187			
A-B	23			23			
A-C	449			449			

18:00 - 18:15

Stream	Total Demand (Veh/hr)	Capacity (Veh/hr)	RFC	Throughput (Veh/hr)	End queue (Veh)	Delay (s)	Unsignalised level of service
B-C	45	547	0.083	45	0.1	7.171	A
B-A	8	420	0.018	8	0.0	8.726	A
C-AB	92	737	0.125	92	0.2	5.595	A
C-A	163			163			
A-B	20			20			
A-C	376			376			

2030 Base + Dev, AM

Data Errors and Warnings

Severity	Area	Item	Description
Warning	Minor arm flare	B - Hither Green Lane (Western Side) - Minor arm geometry	Is flare very short? Estimated flare length is zero but has been increased to 1 because a zero flare length is not allowed.

Junction Network

Junctions

Junction	Name	Junction type	Major road direction	Use circulating lanes	Junction Delay (s)	Junction LOS
1	untitled	T-Junction	Two-way		2.66	A

Junction Network Options

Driving side	Lighting
Left	Normal/unknown

Traffic Demand

Demand Set Details

ID	Scenario name	Time Period name	Traffic profile type	Start time (HH:mm)	Finish time (HH:mm)	Time segment length (min)
D3	2030 Base + Dev	AM	ONE HOUR	07:45	09:15	15

Vehicle mix source	PCU Factor for a HV (PCU)
HV Percentages	2.00

Demand overview (Traffic)

Arm	Linked arm	Use O-D data	Average Demand (Veh/hr)	Scaling Factor (%)
A - Dagnell End Road East		✓	303	100.000
B - Hither Green Lane (Western Side)		✓	199	100.000
C - Dagnell End Road West		✓	481	100.000

Origin-Destination Data

Demand (Veh/hr)

From	To		
	A - Dagnell End Road East	B - Hither Green Lane (Western Side)	C - Dagnell End Road West
A - Dagnell End Road East	0	14	289
B - Hither Green Lane (Western Side)	24	0	175
C - Dagnell End Road West	412	69	0

Vehicle Mix

Heavy Vehicle Percentages

From	To		
	A - Dagnell End Road East	B - Hither Green Lane (Western Side)	C - Dagnell End Road West
A - Dagnell End Road East	0	0	0
B - Hither Green Lane (Western Side)	9	0	0
C - Dagnell End Road West	2	2	0

Results

Results Summary for whole modelled period

Stream	Max RFC	Max Delay (s)	Max Queue (Veh)	Max LOS
B-C	0.35	10.01	0.5	B
B-A	0.08	11.39	0.1	B
C-AB	0.17	4.73	0.4	A
C-A				
A-B				
A-C				

Main Results for each time segment

07:45 - 08:00

Stream	Total Demand (Veh/hr)	Capacity (Veh/hr)	RFC	Throughput (Veh/hr)	End queue (Veh)	Delay (s)	Unsignalised level of service
B-C	132	581	0.227	131	0.3	7.971	A
B-A	18	404	0.045	18	0.0	9.310	A
C-AB	82	844	0.097	81	0.2	4.718	A
C-A	280			280			
A-B	11			11			
A-C	218			218			

08:00 - 08:15

Stream	Total Demand (Veh/hr)	Capacity (Veh/hr)	RFC	Throughput (Veh/hr)	End queue (Veh)	Delay (s)	Unsignalised level of service
B-C	157	569	0.276	157	0.4	8.729	A
B-A	22	379	0.057	22	0.1	10.063	B
C-AB	108	873	0.124	108	0.2	4.703	A
C-A	324			324			
A-B	13			13			
A-C	260			260			

08:15 - 08:30

Stream	Total Demand (Veh/hr)	Capacity (Veh/hr)	RFC	Throughput (Veh/hr)	End queue (Veh)	Delay (s)	Unsignalised level of service
B-C	193	552	0.349	192	0.5	9.980	A
B-A	26	343	0.077	26	0.1	11.376	B
C-AB	151	915	0.165	151	0.3	4.714	A
C-A	378			378			
A-B	15			15			
A-C	318			318			

08:30 - 08:45

Stream	Total Demand (Veh/hr)	Capacity (Veh/hr)	RFC	Throughput (Veh/hr)	End queue (Veh)	Delay (s)	Unsignalised level of service
B-C	193	552	0.349	193	0.5	10.015	B
B-A	26	342	0.077	26	0.1	11.390	B
C-AB	151	915	0.165	151	0.4	4.720	A
C-A	378			378			
A-B	15			15			
A-C	318			318			

08:45 - 09:00

Stream	Total Demand (Veh/hr)	Capacity (Veh/hr)	RFC	Throughput (Veh/hr)	End queue (Veh)	Delay (s)	Unsignalised level of service
B-C	157	569	0.276	158	0.4	8.770	A
B-A	22	379	0.057	22	0.1	10.078	B
C-AB	108	874	0.124	109	0.2	4.715	A
C-A	324			324			
A-B	13			13			
A-C	260			260			

09:00 - 09:15

Stream	Total Demand (Veh/hr)	Capacity (Veh/hr)	RFC	Throughput (Veh/hr)	End queue (Veh)	Delay (s)	Unsignalised level of service
B-C	132	581	0.227	132	0.3	8.027	A
B-A	18	404	0.045	18	0.0	9.331	A
C-AB	82	845	0.098	83	0.2	4.732	A
C-A	280			280			
A-B	11			11			
A-C	218			218			

2030 Base + Dev, PM

Data Errors and Warnings

Severity	Area	Item	Description
Warning	Minor arm flare	B - Hither Green Lane (Western Side) - Minor arm geometry	Is flare very short? Estimated flare length is zero but has been increased to 1 because a zero flare length is not allowed.

Junction Network

Junctions

Junction	Name	Junction type	Major road direction	Use circulating lanes	Junction Delay (s)	Junction LOS
1	untitled	T-Junction	Two-way		3.32	A

Junction Network Options

Driving side	Lighting
Left	Normal/unknown

Traffic Demand

Demand Set Details

ID	Scenario name	Time Period name	Traffic profile type	Start time (HH:mm)	Finish time (HH:mm)	Time segment length (min)
D4	2030 Base + Dev	PM	ONE HOUR	16:45	18:15	15

Vehicle mix source	PCU Factor for a HV (PCU)
HV Percentages	2.00

Demand overview (Traffic)

Arm	Linked arm	Use O-D data	Average Demand (Veh/hr)	Scaling Factor (%)
A - Dagnell End Road East		✓	532	100.000
B - Hither Green Lane (Western Side)		✓	124	100.000
C - Dagnell End Road West		✓	439	100.000

Origin-Destination Data

Demand (Veh/hr)

From	To		
	A - Dagnell End Road East	B - Hither Green Lane (Western Side)	C - Dagnell End Road West
A - Dagnell End Road East	0	33	499
B - Hither Green Lane (Western Side)	13	0	111
C - Dagnell End Road West	247	192	0

Vehicle Mix

Heavy Vehicle Percentages

From	To		
	A - Dagnell End Road East	B - Hither Green Lane (Western Side)	C - Dagnell End Road West
A - Dagnell End Road East	0	0	0
B - Hither Green Lane (Western Side)	0	0	0
C - Dagnell End Road West	1	0	0

Results

Results Summary for whole modelled period

Stream	Max RFC	Max Delay (s)	Max Queue (Veh)	Max LOS
B-C	0.24	9.50	0.3	A
B-A	0.05	12.32	0.0	B
C-AB	0.44	8.65	1.1	A
C-A				
A-B				
A-C				

Main Results for each time segment

16:45 - 17:00

Stream	Total Demand (Veh/hr)	Capacity (Veh/hr)	RFC	Throughput (Veh/hr)	End queue (Veh)	Delay (s)	Unsignalised level of service
B-C	84	546	0.153	83	0.2	7.764	A
B-A	10	392	0.025	10	0.0	9.414	A
C-AB	193	735	0.263	192	0.4	6.611	A
C-A	137			137			
A-B	25			25			
A-C	376			376			

17:00 - 17:15

Stream	Total Demand (Veh/hr)	Capacity (Veh/hr)	RFC	Throughput (Veh/hr)	End queue (Veh)	Delay (s)	Unsignalised level of service
B-C	100	527	0.189	100	0.2	8.412	A
B-A	12	356	0.033	12	0.0	10.444	B
C-AB	247	741	0.333	246	0.6	7.276	A
C-A	148			148			
A-B	30			30			
A-C	449			449			

17:15 - 17:30

Stream	Total Demand (Veh/hr)	Capacity (Veh/hr)	RFC	Throughput (Veh/hr)	End queue (Veh)	Delay (s)	Unsignalised level of service
B-C	122	501	0.244	122	0.3	9.478	A
B-A	14	307	0.047	14	0.0	12.290	B
C-AB	333	751	0.443	331	1.0	8.582	A
C-A	151			151			
A-B	36			36			
A-C	549			549			

17:30 - 17:45

Stream	Total Demand (Veh/hr)	Capacity (Veh/hr)	RFC	Throughput (Veh/hr)	End queue (Veh)	Delay (s)	Unsignalised level of service
B-C	122	501	0.244	122	0.3	9.496	A
B-A	14	307	0.047	14	0.0	12.315	B
C-AB	333	751	0.444	333	1.1	8.652	A
C-A	150			150			
A-B	36			36			
A-C	549			549			

17:45 - 18:00

Stream	Total Demand (Veh/hr)	Capacity (Veh/hr)	RFC	Throughput (Veh/hr)	End queue (Veh)	Delay (s)	Unsignalised level of service
B-C	100	527	0.189	100	0.2	8.435	A
B-A	12	356	0.033	12	0.0	10.468	B
C-AB	248	742	0.334	249	0.7	7.351	A
C-A	147			147			
A-B	30			30			
A-C	449			449			

18:00 - 18:15

Stream	Total Demand (Veh/hr)	Capacity (Veh/hr)	RFC	Throughput (Veh/hr)	End queue (Veh)	Delay (s)	Unsignalised level of service
B-C	84	546	0.153	84	0.2	7.797	A
B-A	10	391	0.025	10	0.0	9.440	A
C-AB	194	736	0.264	195	0.5	6.680	A
C-A	136			136			
A-B	25			25			
A-C	376			376			

Junctions 9
ARCADY 9 - Roundabout Module
Version: 9.5.0.6896 © Copyright TRL Limited, 2018
For sales and distribution information, program advice and maintenance, contact TRL: +44 (0)1344 379777 software@trl.co.uk www.trlsoftware.co.uk
The users of this computer program for the solution of an engineering problem are in no way relieved of their responsibility for the correctness of the solution

Filename: 4 - Weights Lane - Birmingham Road Roundabout.j9
Path: C:\Users\JamesMonk\Dropbox (mode)\Project\Birmingham\2. Projects\J325756_Hither Green Lane, Redditch\4. Data\Junction assessment\Historical application
Report generation date: 05/08/2021 12:06:40

- »2030 Base, AM
- »2030 Base, PM
- »2030 Base + Dev, AM
- »2030 Base + Dev, PM

Summary of junction performance

	AM				PM			
	Queue (Veh)	Delay (s)	RFC	LOS	Queue (Veh)	Delay (s)	RFC	LOS
2030 Base								
1 - A441 (N)	2.8	7.91	0.74	A	2.5	6.81	0.71	A
2 - A441 (S)	1.8	5.60	0.65	A	2.4	6.71	0.71	A
3 - Odell Street	0.2	9.88	0.16	A	0.4	13.92	0.27	B
4 - Weights Lane	0.8	6.54	0.44	A	0.3	5.10	0.26	A
2030 Base + Dev								
1 - A441 (N)	3.3	8.91	0.77	A	2.6	7.16	0.73	A
2 - A441 (S)	1.9	5.75	0.66	A	2.8	7.40	0.74	A
3 - Odell Street	0.2	10.09	0.16	B	0.4	15.15	0.29	C
4 - Weights Lane	0.8	6.66	0.44	A	0.4	5.30	0.27	A

There are warnings associated with one or more model runs - see the 'Data Errors and Warnings' tables for each Analysis or Demand Set.

Values shown are the highest values encountered over all time segments. Delay is the maximum value of average delay per arriving vehicle.

File summary

File Description

Title	
Location	
Site number	
Date	28/07/2021
Version	
Status	(new file)
Identifier	
Client	
Jobnumber	
Enumerator	AzureAD\JamesMonk
Description	

Units

Distance units	Speed units	Traffic units input	Traffic units results	Flow units	Average delay units	Total delay units	Rate of delay units
m	kph	Veh	Veh	perHour	s	-Min	perMin

Analysis Options

Calculate Queue Percentiles	Calculate residual capacity	RFC Threshold	Average Delay threshold (s)	Queue threshold (PCU)
		0.85	36.00	20.00

Demand Set Summary

ID	Scenario name	Time Period name	Traffic profile type	Start time (HH:mm)	Finish time (HH:mm)	Time segment length (min)
D1	2030 Base	AM	ONE HOUR	07:45	09:15	15
D2	2030 Base	PM	ONE HOUR	16:45	18:15	15
D3	2030 Base + Dev	AM	ONE HOUR	07:45	09:15	15
D4	2030 Base + Dev	PM	ONE HOUR	16:45	18:15	15

Analysis Set Details

ID	Network flow scaling factor (%)
A1	100.000

2030 Base, AM

Data Errors and Warnings

Severity	Area	Item	Description
Warning	Geometry	1 - A441 (N) - Roundabout Geometry	Effective flare length is over 30m, which is outside the normal range. Treat capacities with increasing caution.
Warning	Geometry	2 - A441 (S) - Roundabout Geometry	Effective flare length is over 30m, which is outside the normal range. Treat capacities with increasing caution.

Junction Network

Junctions

Junction	Name	Junction type	Use circulating lanes	Arm order	Junction Delay (s)	Junction LOS
1	untitled	Standard Roundabout		1, 2, 3, 4	6.84	A

Junction Network Options

Driving side	Lighting
Left	Normal/unknown

Arms

Arms

Arm	Name	Description
1	A441 (N)	
2	A441 (S)	
3	Odell Street	
4	Weights Lane	

Roundabout Geometry

Arm	V - Approach road half-width (m)	E - Entry width (m)	I' - Effective flare length (m)	R - Entry radius (m)	D - Inscribed circle diameter (m)	PHI - Conflict (entry) angle (deg)	Exit only
1 - A441 (N)	4.70	8.55	39.0	40.0	54.8	80.0	
2 - A441 (S)	4.40	8.40	58.0	20.0	53.5	68.5	
3 - Odell Street	3.80	3.80	0.0	20.0	54.8	75.0	
4 - Weights Lane	4.50	7.00	16.0	40.0	53.8	78.5	

Slope / Intercept / Capacity

Roundabout Slope and Intercept used in model

Arm	Final slope	Final intercept (PCU/hr)
1 - A441 (N)	0.593	1966
2 - A441 (S)	0.613	2015
3 - Odell Street	0.410	972
4 - Weights Lane	0.532	1600

The slope and intercept shown above include any corrections and adjustments.

Traffic Demand

Demand Set Details

ID	Scenario name	Time Period name	Traffic profile type	Start time (HH:mm)	Finish time (HH:mm)	Time segment length (min)
D1	2030 Base	AM	ONE HOUR	07:45	09:15	15

Vehicle mix source	PCU Factor for a HV (PCU)
HV Percentages	2.00

Demand overview (Traffic)

Arm	Linked arm	Use O-D data	Average Demand (Veh/hr)	Scaling Factor (%)
1 - A441 (N)		✓	1195	100.000
2 - A441 (S)		✓	1077	100.000
3 - Odell Street		✓	64	100.000
4 - Weights Lane		✓	393	100.000

Origin-Destination Data

Demand (Veh/hr)

		To			
		1 - A441 (N)	2 - A441 (S)	3 - Odell Street	4 - Weights Lane
From	1 - A441 (N)	0	1056	40	99
	2 - A441 (S)	933	0	59	85
	3 - Odell Street	26	21	0	17
	4 - Weights Lane	221	172	0	0

Vehicle Mix

Heavy Vehicle Percentages

		To			
		1 - A441 (N)	2 - A441 (S)	3 - Odell Street	4 - Weights Lane
From	1 - A441 (N)	0	4	0	0
	2 - A441 (S)	4	0	9	13
	3 - Odell Street	0	8	0	0
	4 - Weights Lane	1	3	0	0

Results

Results Summary for whole modelled period

Arm	Max RFC	Max Delay (s)	Max Queue (Veh)	Max LOS
1 - A441 (N)	0.74	7.91	2.8	A
2 - A441 (S)	0.65	5.60	1.8	A
3 - Odell Street	0.16	9.88	0.2	A
4 - Weights Lane	0.44	6.54	0.8	A

Main Results for each time segment

07:45 - 08:00

Arm	Total Demand (Veh/hr)	Circulating flow (Veh/hr)	Capacity (Veh/hr)	RFC	Throughput (Veh/hr)	End queue (Veh)	Delay (s)	Unsignalised level of service
1 - A441 (N)	900	145	1810	0.497	896	1.0	3.920	A
2 - A441 (S)	811	104	1857	0.437	808	0.8	3.422	A
3 - Odell Street	48	838	598	0.081	48	0.1	6.534	A
4 - Weights Lane	296	735	1170	0.253	295	0.3	4.106	A

08:00 - 08:15

Arm	Total Demand (Veh/hr)	Circulating flow (Veh/hr)	Capacity (Veh/hr)	RFC	Throughput (Veh/hr)	End queue (Veh)	Delay (s)	Unsignalised level of service
1 - A441 (N)	1074	173	1793	0.599	1072	1.5	4.978	A
2 - A441 (S)	968	125	1845	0.525	967	1.1	4.095	A
3 - Odell Street	58	1003	529	0.109	57	0.1	7.624	A
4 - Weights Lane	353	880	1091	0.324	353	0.5	4.872	A

08:15 - 08:30

Arm	Total Demand (Veh/hr)	Circulating flow (Veh/hr)	Capacity (Veh/hr)	RFC	Throughput (Veh/hr)	End queue (Veh)	Delay (s)	Unsignalised level of service
1 - A441 (N)	1316	212	1770	0.743	1310	2.8	7.736	A
2 - A441 (S)	1186	152	1829	0.648	1183	1.8	5.551	A
3 - Odell Street	70	1227	436	0.162	70	0.2	9.837	A
4 - Weights Lane	433	1076	984	0.440	432	0.8	6.497	A

08:30 - 08:45

Arm	Total Demand (Veh/hr)	Circulating flow (Veh/hr)	Capacity (Veh/hr)	RFC	Throughput (Veh/hr)	End queue (Veh)	Delay (s)	Unsignalised level of service
1 - A441 (N)	1316	212	1770	0.743	1316	2.8	7.912	A
2 - A441 (S)	1186	153	1828	0.649	1186	1.8	5.602	A
3 - Odell Street	70	1230	435	0.162	70	0.2	9.885	A
4 - Weights Lane	433	1079	983	0.440	433	0.8	6.542	A

08:45 - 09:00

Arm	Total Demand (Veh/hr)	Circulating flow (Veh/hr)	Capacity (Veh/hr)	RFC	Throughput (Veh/hr)	End queue (Veh)	Delay (s)	Unsignalised level of service
1 - A441 (N)	1074	174	1793	0.599	1080	1.5	5.084	A
2 - A441 (S)	968	126	1844	0.525	971	1.1	4.135	A
3 - Odell Street	58	1007	528	0.109	58	0.1	7.667	A
4 - Weights Lane	353	884	1089	0.324	354	0.5	4.908	A

09:00 - 09:15

Arm	Total Demand (Veh/hr)	Circulating flow (Veh/hr)	Capacity (Veh/hr)	RFC	Throughput (Veh/hr)	End queue (Veh)	Delay (s)	Unsignalised level of service
1 - A441 (N)	900	146	1810	0.497	902	1.0	3.975	A
2 - A441 (S)	811	105	1856	0.437	812	0.8	3.451	A
3 - Odell Street	48	842	596	0.081	48	0.1	6.571	A
4 - Weights Lane	296	739	1168	0.253	296	0.3	4.134	A

2030 Base, PM

Data Errors and Warnings

Severity	Area	Item	Description
Warning	Geometry	1 - A441 (N) - Roundabout Geometry	Effective flare length is over 30m, which is outside the normal range. Treat capacities with increasing caution.
Warning	Geometry	2 - A441 (S) - Roundabout Geometry	Effective flare length is over 30m, which is outside the normal range. Treat capacities with increasing caution.

Junction Network

Junctions

Junction	Name	Junction type	Use circulating lanes	Arm order	Junction Delay (s)	Junction LOS
1	untitled	Standard Roundabout		1, 2, 3, 4	6.85	A

Junction Network Options

Driving side	Lighting
Left	Normal/unknown

Traffic Demand

Demand Set Details

ID	Scenario name	Time Period name	Traffic profile type	Start time (HH:mm)	Finish time (HH:mm)	Time segment length (min)
D2	2030 Base	PM	ONE HOUR	16:45	18:15	15

Vehicle mix source	PCU Factor for a HV (PCU)
HV Percentages	2.00

Demand overview (Traffic)

Arm	Linked arm	Use O-D data	Average Demand (Veh/hr)	Scaling Factor (%)
1 - A441 (N)		✓	1203	100.000
2 - A441 (S)		✓	1192	100.000
3 - Odell Street		✓	87	100.000
4 - Weights Lane		✓	223	100.000

Origin-Destination Data

Demand (Veh/hr)

		To			
		1 - A441 (N)	2 - A441 (S)	3 - Odell Street	4 - Weights Lane
From	1 - A441 (N)	0	985	18	200
	2 - A441 (S)	1001	0	36	155
	3 - Odell Street	39	48	0	0
	4 - Weights Lane	120	103	0	0

Vehicle Mix

Heavy Vehicle Percentages

	To			
	1 - A441 (N)	2 - A441 (S)	3 - Odell Street	4 - Weights Lane
From				
1 - A441 (N)	0	1	0	0
2 - A441 (S)	1	0	0	2
3 - Odell Street	0	0	0	0
4 - Weights Lane	1	0	0	0

Results

Results Summary for whole modelled period

Arm	Max RFC	Max Delay (s)	Max Queue (Veh)	Max LOS
1 - A441 (N)	0.71	6.81	2.5	A
2 - A441 (S)	0.71	6.71	2.4	A
3 - Odell Street	0.27	13.92	0.4	B
4 - Weights Lane	0.26	5.10	0.3	A

Main Results for each time segment

16:45 - 17:00

Arm	Total Demand (Veh/hr)	Circulating flow (Veh/hr)	Capacity (Veh/hr)	RFC	Throughput (Veh/hr)	End queue (Veh)	Delay (s)	Unsignalised level of service
1 - A441 (N)	906	113	1884	0.481	902	0.9	3.653	A
2 - A441 (S)	897	163	1895	0.474	894	0.9	3.582	A
3 - Odell Street	65	1017	551	0.119	65	0.1	7.397	A
4 - Weights Lane	168	816	1156	0.145	167	0.2	3.638	A

17:00 - 17:15

Arm	Total Demand (Veh/hr)	Circulating flow (Veh/hr)	Capacity (Veh/hr)	RFC	Throughput (Veh/hr)	End queue (Veh)	Delay (s)	Unsignalised level of service
1 - A441 (N)	1081	135	1871	0.578	1080	1.4	4.542	A
2 - A441 (S)	1072	196	1876	0.571	1070	1.3	4.460	A
3 - Odell Street	78	1217	468	0.167	78	0.2	9.216	A
4 - Weights Lane	200	976	1070	0.187	200	0.2	4.137	A

17:15 - 17:30

Arm	Total Demand (Veh/hr)	Circulating flow (Veh/hr)	Capacity (Veh/hr)	RFC	Throughput (Veh/hr)	End queue (Veh)	Delay (s)	Unsignalised level of service
1 - A441 (N)	1325	166	1853	0.715	1320	2.4	6.704	A
2 - A441 (S)	1312	239	1849	0.710	1308	2.4	6.602	A
3 - Odell Street	96	1488	356	0.269	95	0.4	13.752	B
4 - Weights Lane	246	1194	954	0.257	245	0.3	5.073	A

17:30 - 17:45

Arm	Total Demand (Veh/hr)	Circulating flow (Veh/hr)	Capacity (Veh/hr)	RFC	Throughput (Veh/hr)	End queue (Veh)	Delay (s)	Unsignalised level of service
1 - A441 (N)	1325	166	1853	0.715	1324	2.5	6.812	A
2 - A441 (S)	1312	240	1849	0.710	1312	2.4	6.707	A
3 - Odell Street	96	1493	354	0.270	96	0.4	13.922	B
4 - Weights Lane	246	1198	952	0.258	246	0.3	5.095	A

17:45 - 18:00

Arm	Total Demand (Veh/hr)	Circulating flow (Veh/hr)	Capacity (Veh/hr)	RFC	Throughput (Veh/hr)	End queue (Veh)	Delay (s)	Unsignalised level of service
1 - A441 (N)	1081	136	1870	0.578	1086	1.4	4.614	A
2 - A441 (S)	1072	197	1875	0.572	1076	1.3	4.529	A
3 - Odell Street	78	1224	466	0.168	79	0.2	9.325	A
4 - Weights Lane	200	982	1067	0.188	201	0.2	4.159	A

18:00 - 18:15

Arm	Total Demand (Veh/hr)	Circulating flow (Veh/hr)	Capacity (Veh/hr)	RFC	Throughput (Veh/hr)	End queue (Veh)	Delay (s)	Unsignalised level of service
1 - A441 (N)	906	114	1883	0.481	907	0.9	3.698	A
2 - A441 (S)	897	164	1894	0.474	899	0.9	3.622	A
3 - Odell Street	65	1023	549	0.119	66	0.1	7.461	A
4 - Weights Lane	168	821	1153	0.146	168	0.2	3.653	A

2030 Base + Dev, AM

Data Errors and Warnings

Severity	Area	Item	Description
Warning	Geometry	1 - A441 (N) - Roundabout Geometry	Effective flare length is over 30m, which is outside the normal range. Treat capacities with increasing caution.
Warning	Geometry	2 - A441 (S) - Roundabout Geometry	Effective flare length is over 30m, which is outside the normal range. Treat capacities with increasing caution.

Junction Network

Junctions

Junction	Name	Junction type	Use circulating lanes	Arm order	Junction Delay (s)	Junction LOS
1	untitled	Standard Roundabout		1, 2, 3, 4	7.38	A

Junction Network Options

Driving side	Lighting
Left	Normal/unknown

Traffic Demand

Demand Set Details

ID	Scenario name	Time Period name	Traffic profile type	Start time (HH:mm)	Finish time (HH:mm)	Time segment length (min)
D3	2030 Base + Dev	AM	ONE HOUR	07:45	09:15	15

Vehicle mix source	PCU Factor for a HV (PCU)
HV Percentages	2.00

Demand overview (Traffic)

Arm	Linked arm	Use O-D data	Average Demand (Veh/hr)	Scaling Factor (%)
1 - A441 (N)		✓	1244	100.000
2 - A441 (S)		✓	1094	100.000
3 - Odell Street		✓	64	100.000
4 - Weights Lane		✓	393	100.000

Origin-Destination Data

Demand (Veh/hr)

		To			
		1 - A441 (N)	2 - A441 (S)	3 - Odell Street	4 - Weights Lane
From	1 - A441 (N)	0	1105	40	99
	2 - A441 (S)	950	0	59	85
	3 - Odell Street	26	21	0	17
	4 - Weights Lane	221	172	0	0

Vehicle Mix

Heavy Vehicle Percentages

	To			
	1 - A441 (N)	2 - A441 (S)	3 - Odell Street	4 - Weights Lane
From				
1 - A441 (N)	0	4	0	0
2 - A441 (S)	4	0	9	13
3 - Odell Street	0	8	0	0
4 - Weights Lane	1	3	0	0

Results

Results Summary for whole modelled period

Arm	Max RFC	Max Delay (s)	Max Queue (Veh)	Max LOS
1 - A441 (N)	0.77	8.91	3.3	A
2 - A441 (S)	0.66	5.75	1.9	A
3 - Odell Street	0.16	10.09	0.2	B
4 - Weights Lane	0.44	6.66	0.8	A

Main Results for each time segment

07:45 - 08:00

Arm	Total Demand (Veh/hr)	Circulating flow (Veh/hr)	Capacity (Veh/hr)	RFC	Throughput (Veh/hr)	End queue (Veh)	Delay (s)	Unsignalised level of service
1 - A441 (N)	937	145	1813	0.517	932	1.1	4.068	A
2 - A441 (S)	824	104	1859	0.443	820	0.8	3.458	A
3 - Odell Street	48	850	593	0.081	48	0.1	6.594	A
4 - Weights Lane	296	748	1163	0.254	295	0.3	4.137	A

08:00 - 08:15

Arm	Total Demand (Veh/hr)	Circulating flow (Veh/hr)	Capacity (Veh/hr)	RFC	Throughput (Veh/hr)	End queue (Veh)	Delay (s)	Unsignalised level of service
1 - A441 (N)	1118	173	1796	0.623	1116	1.6	5.276	A
2 - A441 (S)	983	125	1847	0.533	982	1.1	4.157	A
3 - Odell Street	58	1018	523	0.110	57	0.1	7.722	A
4 - Weights Lane	353	895	1083	0.326	353	0.5	4.927	A

08:15 - 08:30

Arm	Total Demand (Veh/hr)	Circulating flow (Veh/hr)	Capacity (Veh/hr)	RFC	Throughput (Veh/hr)	End queue (Veh)	Delay (s)	Unsignalised level of service
1 - A441 (N)	1370	212	1773	0.772	1363	3.3	8.643	A
2 - A441 (S)	1205	152	1830	0.658	1201	1.9	5.696	A
3 - Odell Street	70	1245	429	0.164	70	0.2	10.035	B
4 - Weights Lane	433	1095	975	0.444	431	0.8	6.611	A

08:30 - 08:45

Arm	Total Demand (Veh/hr)	Circulating flow (Veh/hr)	Capacity (Veh/hr)	RFC	Throughput (Veh/hr)	End queue (Veh)	Delay (s)	Unsignalised level of service
1 - A441 (N)	1370	212	1773	0.773	1369	3.3	8.909	A
2 - A441 (S)	1205	153	1830	0.658	1204	1.9	5.752	A
3 - Odell Street	70	1248	427	0.165	70	0.2	10.089	B
4 - Weights Lane	433	1098	973	0.445	433	0.8	6.658	A

08:45 - 09:00

Arm	Total Demand (Veh/hr)	Circulating flow (Veh/hr)	Capacity (Veh/hr)	RFC	Throughput (Veh/hr)	End queue (Veh)	Delay (s)	Unsignalised level of service
1 - A441 (N)	1118	174	1796	0.623	1125	1.7	5.421	A
2 - A441 (S)	983	126	1846	0.533	987	1.2	4.202	A
3 - Odell Street	58	1023	521	0.110	58	0.1	7.769	A
4 - Weights Lane	353	899	1081	0.327	355	0.5	4.962	A

09:00 - 09:15

Arm	Total Demand (Veh/hr)	Circulating flow (Veh/hr)	Capacity (Veh/hr)	RFC	Throughput (Veh/hr)	End queue (Veh)	Delay (s)	Unsignalised level of service
1 - A441 (N)	937	146	1812	0.517	939	1.1	4.132	A
2 - A441 (S)	824	105	1858	0.443	825	0.8	3.488	A
3 - Odell Street	48	855	591	0.081	48	0.1	6.630	A
4 - Weights Lane	296	752	1161	0.255	296	0.3	4.167	A

2030 Base + Dev, PM

Data Errors and Warnings

Severity	Area	Item	Description
Warning	Geometry	1 - A441 (N) - Roundabout Geometry	Effective flare length is over 30m, which is outside the normal range. Treat capacities with increasing caution.
Warning	Geometry	2 - A441 (S) - Roundabout Geometry	Effective flare length is over 30m, which is outside the normal range. Treat capacities with increasing caution.

Junction Network

Junctions

Junction	Name	Junction type	Use circulating lanes	Arm order	Junction Delay (s)	Junction LOS
1	untitled	Standard Roundabout		1, 2, 3, 4	7.37	A

Junction Network Options

Driving side	Lighting
Left	Normal/unknown

Traffic Demand

Demand Set Details

ID	Scenario name	Time Period name	Traffic profile type	Start time (HH:mm)	Finish time (HH:mm)	Time segment length (min)
D4	2030 Base + Dev	PM	ONE HOUR	16:45	18:15	15

Vehicle mix source	PCU Factor for a HV (PCU)
HV Percentages	2.00

Demand overview (Traffic)

Arm	Linked arm	Use O-D data	Average Demand (Veh/hr)	Scaling Factor (%)
1 - A441 (N)		✓	1226	100.000
2 - A441 (S)		✓	1238	100.000
3 - Odell Street		✓	87	100.000
4 - Weights Lane		✓	223	100.000

Origin-Destination Data

Demand (Veh/hr)

		To			
		1 - A441 (N)	2 - A441 (S)	3 - Odell Street	4 - Weights Lane
From	1 - A441 (N)	0	1008	18	200
	2 - A441 (S)	1047	0	36	155
	3 - Odell Street	39	48	0	0
	4 - Weights Lane	120	103	0	0

Vehicle Mix

Heavy Vehicle Percentages

From	To			
	1 - A441 (N)	2 - A441 (S)	3 - Odell Street	4 - Weights Lane
1 - A441 (N)	0	1	0	0
2 - A441 (S)	1	0	0	2
3 - Odell Street	0	0	0	0
4 - Weights Lane	1	0	0	0

Results

Results Summary for whole modelled period

Arm	Max RFC	Max Delay (s)	Max Queue (Veh)	Max LOS
1 - A441 (N)	0.73	7.16	2.6	A
2 - A441 (S)	0.74	7.40	2.8	A
3 - Odell Street	0.29	15.15	0.4	C
4 - Weights Lane	0.27	5.30	0.4	A

Main Results for each time segment

16:45 - 17:00

Arm	Total Demand (Veh/hr)	Circulating flow (Veh/hr)	Capacity (Veh/hr)	RFC	Throughput (Veh/hr)	End queue (Veh)	Delay (s)	Unsignalised level of service
1 - A441 (N)	923	113	1884	0.490	919	1.0	3.721	A
2 - A441 (S)	932	163	1895	0.492	928	1.0	3.707	A
3 - Odell Street	65	1051	537	0.122	65	0.1	7.620	A
4 - Weights Lane	168	850	1138	0.148	167	0.2	3.707	A

17:00 - 17:15

Arm	Total Demand (Veh/hr)	Circulating flow (Veh/hr)	Capacity (Veh/hr)	RFC	Throughput (Veh/hr)	End queue (Veh)	Delay (s)	Unsignalised level of service
1 - A441 (N)	1102	135	1871	0.589	1100	1.4	4.662	A
2 - A441 (S)	1113	196	1876	0.593	1111	1.4	4.696	A
3 - Odell Street	78	1258	451	0.173	78	0.2	9.635	A
4 - Weights Lane	200	1018	1048	0.191	200	0.2	4.244	A

17:15 - 17:30

Arm	Total Demand (Veh/hr)	Circulating flow (Veh/hr)	Capacity (Veh/hr)	RFC	Throughput (Veh/hr)	End queue (Veh)	Delay (s)	Unsignalised level of service
1 - A441 (N)	1350	166	1853	0.729	1345	2.6	7.025	A
2 - A441 (S)	1363	239	1849	0.737	1358	2.7	7.254	A
3 - Odell Street	96	1538	336	0.285	95	0.4	14.915	B
4 - Weights Lane	246	1243	927	0.265	245	0.4	5.272	A

17:30 - 17:45

Arm	Total Demand (Veh/hr)	Circulating flow (Veh/hr)	Capacity (Veh/hr)	RFC	Throughput (Veh/hr)	End queue (Veh)	Delay (s)	Unsignalised level of service
1 - A441 (N)	1350	166	1852	0.729	1350	2.6	7.156	A
2 - A441 (S)	1363	240	1849	0.737	1363	2.8	7.403	A
3 - Odell Street	96	1543	333	0.287	96	0.4	15.146	C
4 - Weights Lane	246	1248	925	0.265	246	0.4	5.298	A

17:45 - 18:00

Arm	Total Demand (Veh/hr)	Circulating flow (Veh/hr)	Capacity (Veh/hr)	RFC	Throughput (Veh/hr)	End queue (Veh)	Delay (s)	Unsignalised level of service
1 - A441 (N)	1102	136	1870	0.589	1107	1.5	4.746	A
2 - A441 (S)	1113	197	1875	0.594	1118	1.5	4.788	A
3 - Odell Street	78	1266	448	0.175	79	0.2	9.774	A
4 - Weights Lane	200	1025	1045	0.192	201	0.2	4.269	A

18:00 - 18:15

Arm	Total Demand (Veh/hr)	Circulating flow (Veh/hr)	Capacity (Veh/hr)	RFC	Throughput (Veh/hr)	End queue (Veh)	Delay (s)	Unsignalised level of service
1 - A441 (N)	923	114	1883	0.490	925	1.0	3.763	A
2 - A441 (S)	932	164	1894	0.492	934	1.0	3.755	A
3 - Odell Street	65	1058	534	0.123	66	0.1	7.690	A
4 - Weights Lane	168	856	1135	0.148	168	0.2	3.727	A

Full Input Data And Results
Full Input Data And Results

User and Project Details

Project:	
Title:	A441 / Dagnell End Road
Location:	
Additional detail:	
File name:	A441_Dagnell End Rd v2.lsg3x
Author:	al
Company:	
Address:	

Network Layout Diagram

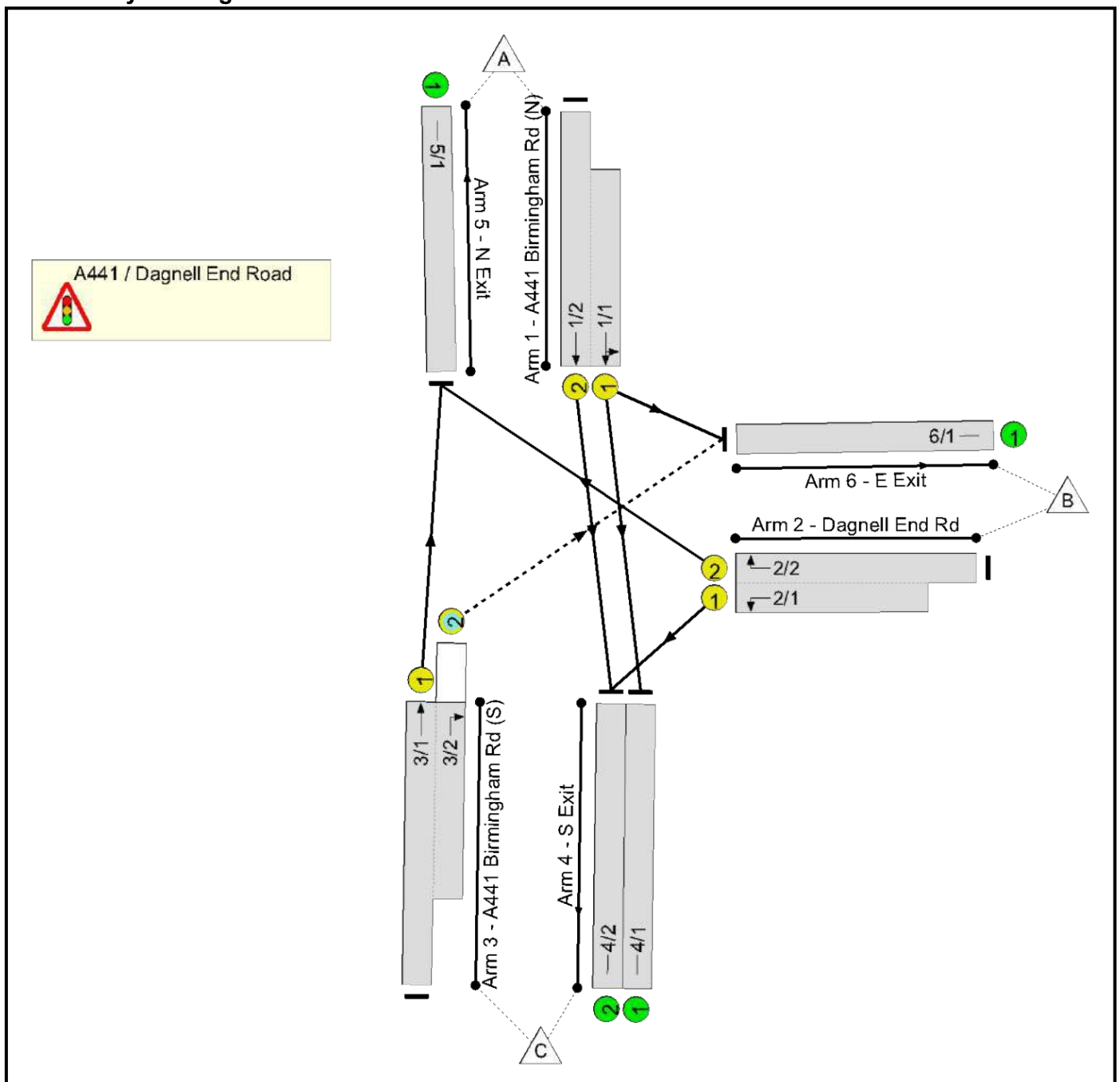

Phase Diagram

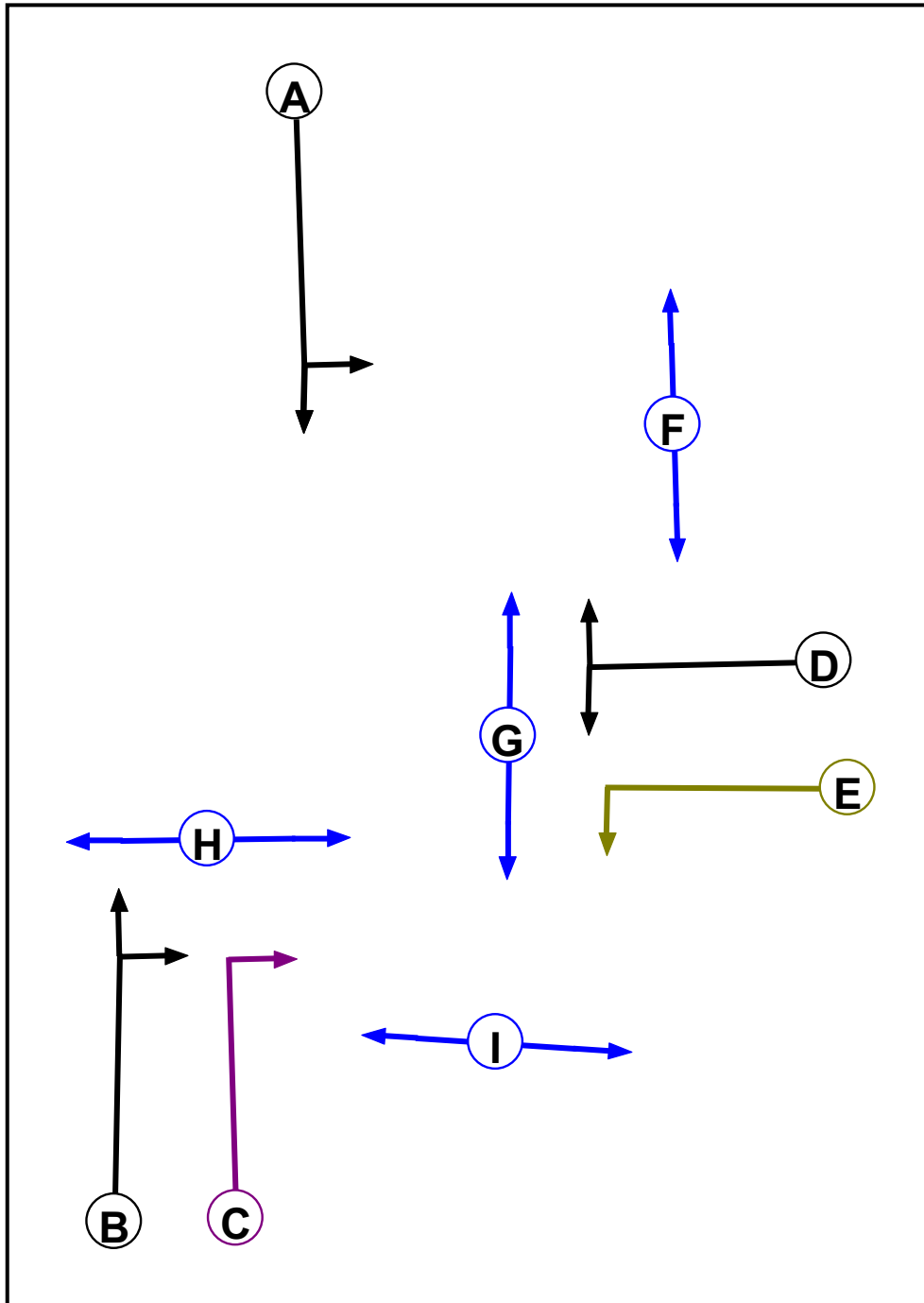

Full Input Data And Results

Phase Input Data

Phase Name	Phase Type	Assoc. Phase	Street Min	Cont Min
A	Traffic		7	7
B	Traffic		7	7
C	Ind. Arrow	B	4	4
D	Traffic		7	7
E	Filter	D	4	0
F	Pedestrian		6	6
G	Pedestrian		6	6
H	Pedestrian		6	6
I	Pedestrian		6	6

Phase Intergreens Matrix

		Starting Phase								
		A	B	C	D	E	F	G	H	I
Terminating Phase	A	-	5	7	7	7	-	-	9	
	B	-	-	6	-	8	-	5	-	
	C	7	-	6	-	8	-	5	-	
	D	7	7	7	-	-	5	-	7	
	E	6	-	-	-	-	5	-	7	
	F	8	8	8	-	-	-	-	-	
	G	-	-	8	8	-	-	-	-	
	H	-	8	8	-	-	-	-	-	
	I	9	-	-	9	9	-	-	-	

Phases in Stage

Stage No.	Phases in Stage
1	A B G
2	B C G I
3	D F H
4	A B
5	B C E
6	B C
7	D

Full Input Data And Results

Stage Diagram

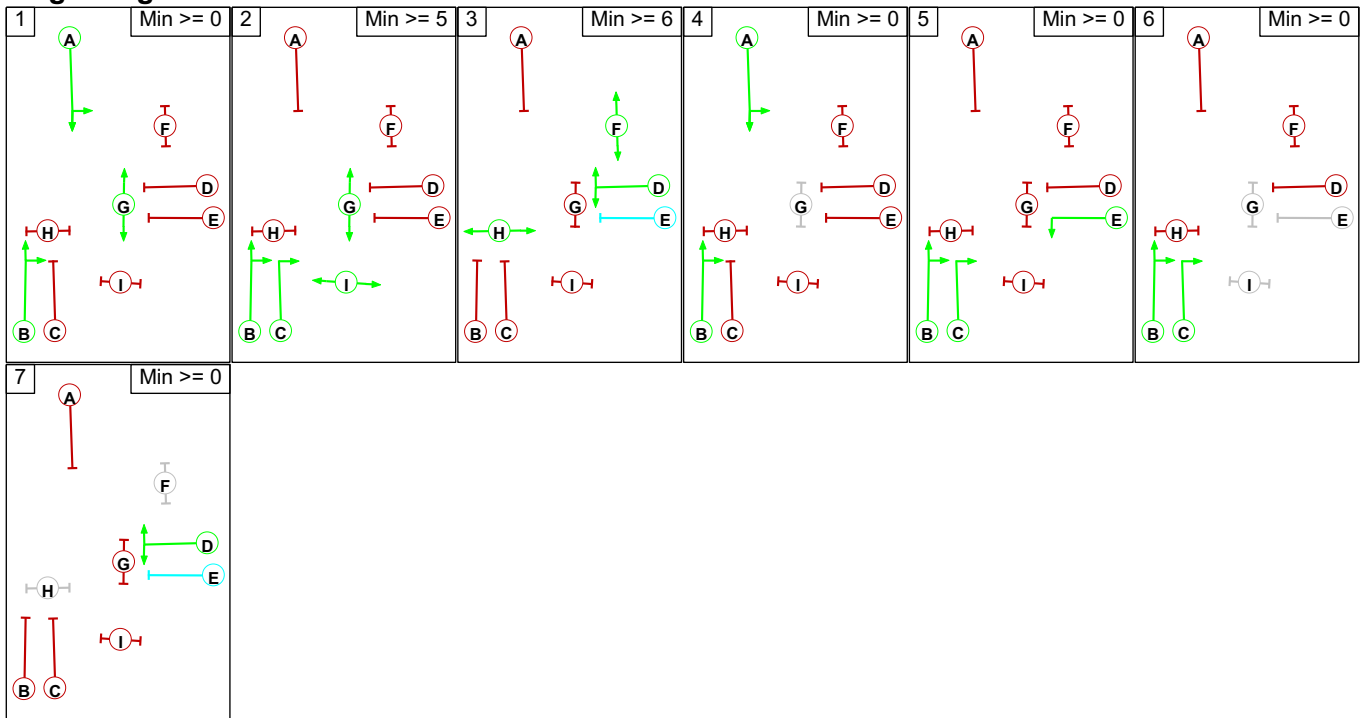

Phase Delays

Term. Stage	Start Stage	Phase	Type	Value	Cont value
2	3	B	Losing	3	3
3	1	D	Losing	1	1

Prohibited Stage Change

		To Stage						
		1	2	3	4	5	6	7
From Stage	1	█	9	8	0	8	5	8
	2	9	█	11	9	9	0	9
	3	8	8	█	8	8	8	0
	4	0	9	8	█	7	5	7
	5	X	X	8	X	█	X	6
	6	7	0	8	7	0	█	6
	7	7	7	0	7	7	7	█

Full Input Data And Results

Give-Way Lane Input Data

Junction: A441 / Dagnell End Road											
Lane	Movement	Max Flow when Giving Way (PCU/Hr)	Min Flow when Giving Way (PCU/Hr)	Opposing Lane	Opp. Lane Coeff.	Opp. Mvmnts.	Right Turn Storage (PCU)	Non-Blocking Storage (PCU)	RTF	Right Turn Move up (s)	Max Turns in Intergreen (PCU)
3/2 (A441 Birmingham Rd (S))	6/1 (Right)	1439	0	1/1 1/2	1.09 1.09	All All	3.00	-	0.50	3	3.00

Full Input Data And Results

Lane Input Data

Junction: A441 / Dagnell End Road												
Lane	Lane Type	Phases	Start Disp.	End Disp.	Physical Length (PCU)	Sat Flow Type	Def User Saturation Flow (PCU/Hr)	Lane Width (m)	Gradient	Nearside Lane	Turns	Turning Radius (m)
1/1 (A441 Birmingham Rd (N))	U	A	2	3	10.0	Geom	-	3.50	0.00	Y	Arm 4 Ahead Arm 6 Left	Inf 9.00
1/2 (A441 Birmingham Rd (N))	U	A	2	3	60.0	Geom	-	3.50	0.00	N	Arm 4 Ahead	Inf
2/1 (Dagnell End Rd)	U	D E	2	3	11.0	Geom	-	3.65	0.00	Y	Arm 4 Left	11.00
2/2 (Dagnell End Rd)	U	D	2	3	60.0	Geom	-	3.65	0.00	Y	Arm 5 Right	17.00
3/1 (A441 Birmingham Rd (S))	U	B	2	3	60.0	User	1800	-	-	-	-	-
3/2 (A441 Birmingham Rd (S))	O	B C	2	3	10.0	User	1800	-	-	-	-	-
4/1 (S Exit)	U		2	3	60.0	Inf	-	-	-	-	-	-
4/2 (S Exit)	U		2	3	60.0	Inf	-	-	-	-	-	-
5/1 (N Exit)	U		2	3	60.0	Inf	-	-	-	-	-	-
6/1 (E Exit)	U		2	3	60.0	Inf	-	-	-	-	-	-

Traffic Flow Groups

Flow Group	Start Time	End Time	Duration	Formula
1: '2030 AM Effective Base'	08:00	09:00	01:00	
2: '2030 PM Effective Base'	17:00	18:00	01:00	
3: '2030 AM Effective Base + Dev'	08:00	09:00	01:00	
4: '2030 PM Effective Base + Dev'	17:00	18:00	01:00	

Full Input Data And Results

Scenario 1: '1' (FG1: '2030 AM Effective Base', Plan 1: 'Network Control Plan 1 (no Peds)')

Traffic Flows, Desired

Desired Flow :

		Destination			
		A	B	C	Tot.
Origin	A	0	206	1078	1284
	B	197	0	210	407
	C	1145	241	0	1386
	Tot.	1342	447	1288	3077

Traffic Lane Flows

Lane	Scenario 1: 1
Junction: A441 / Dagnell End Road	
1/1 (short)	989
1/2 (with short)	1284(In) 295(Out)
2/1 (short)	210
2/2 (with short)	407(In) 197(Out)
3/1 (with short)	1386(In) 1145(Out)
3/2 (short)	241
4/1	783
4/2	505
5/1	1342
6/1	447

Full Input Data And Results

Lane Saturation Flows

Junction: A441 / Dagnell End Road								
Lane	Lane Width (m)	Gradient	Nearside Lane	Allowed Turns	Turning Radius (m)	Turning Prop.	Sat Flow (PCU/Hr)	Flared Sat Flow (PCU/Hr)
1/1 (A441 Birmingham Rd (N))	3.50	0.00	Y	Arm 4 Ahead	Inf	79.2 %	1899	1899
1/2 (A441 Birmingham Rd (N))	3.50	0.00	N	Arm 4 Ahead	9.00	20.8 %	2105	2105
2/1 (Dagnell End Rd)	3.65	0.00	Y	Arm 4 Left	11.00	100.0 %	1742	1742
2/2 (Dagnell End Rd)	3.65	0.00	Y	Arm 5 Right	17.00	100.0 %	1819	1819
3/1 (A441 Birmingham Rd (S) Lane 1)	This lane uses a directly entered Saturation Flow						1726	1726
3/2 (A441 Birmingham Rd (S) Lane 2)	This lane uses a directly entered Saturation Flow						1679	1679
4/1 (S Exit Lane 1)	Infinite Saturation Flow						Inf	Inf
4/2 (S Exit Lane 2)	Infinite Saturation Flow						Inf	Inf
5/1 (N Exit Lane 1)	Infinite Saturation Flow						Inf	Inf
6/1 (E Exit Lane 1)	Infinite Saturation Flow						Inf	Inf

Scenario 2: '2' (FG2: '2030 PM Effective Base', Plan 1: 'Network Control Plan 1 (no Peds)')

Traffic Flows, Desired

Desired Flow :

	Destination				
		A	B	C	Tot.
Origin	A	0	132	1043	1175
	B	379	0	255	634
	C	1188	175	0	1363
	Tot.	1567	307	1298	3172

Full Input Data And Results

Traffic Lane Flows

Lane	Scenario 2: 2
Junction: A441 / Dagnell End Road	
1/1 (short)	905
1/2 (with short)	1175(In) 270(Out)
2/1 (short)	255
2/2 (with short)	634(In) 379(Out)
3/1 (with short)	1363(In) 1188(Out)
3/2 (short)	175
4/1	773
4/2	525
5/1	1567
6/1	307

Lane Saturation Flows

Junction: A441 / Dagnell End Road								
Lane	Lane Width (m)	Gradient	Nearside Lane	Allowed Turns	Turning Radius (m)	Turning Prop.	Sat Flow (PCU/Hr)	Flared Sat Flow (PCU/Hr)
1/1 (A441 Birmingham Rd (N))	3.50	0.00	Y	Arm 4 Ahead	Inf	85.4 %	1918	1918
				Arm 6 Left	9.00	14.6 %		
1/2 (A441 Birmingham Rd (N))	3.50	0.00	N	Arm 4 Ahead	Inf	100.0 %	2105	2105
2/1 (Dagnell End Rd)	3.65	0.00	Y	Arm 4 Left	11.00	100.0 %	1742	1742
2/2 (Dagnell End Rd)	3.65	0.00	Y	Arm 5 Right	17.00	100.0 %	1819	1819
3/1 (A441 Birmingham Rd (S) Lane 1)	This lane uses a directly entered Saturation Flow						1641	1641
3/2 (A441 Birmingham Rd (S) Lane 2)	This lane uses a directly entered Saturation Flow						1800	1800
4/1 (S Exit Lane 1)	Infinite Saturation Flow						Inf	Inf
4/2 (S Exit Lane 2)	Infinite Saturation Flow						Inf	Inf
5/1 (N Exit Lane 1)	Infinite Saturation Flow						Inf	Inf
6/1 (E Exit Lane 1)	Infinite Saturation Flow						Inf	Inf

Full Input Data And Results

Scenario 3: '3' (FG3: '2030 AM Effective Base + Dev', Plan 1: 'Network Control Plan 1 (no Peds)')

Traffic Flows, Desired

Desired Flow :

	Destination				
	A	B	C	Tot.	
Origin	A	0	226	1078	1304
	B	255	0	259	514
	C	1145	258	0	1403
	Tot.	1400	484	1337	3221

Traffic Lane Flows

Lane	Scenario 3: 3
Junction: A441 / Dagnell End Road	
1/1 (short)	1004
1/2 (with short)	1304(In) 300(Out)
2/1 (short)	259
2/2 (with short)	514(In) 255(Out)
3/1 (with short)	1403(In) 1145(Out)
3/2 (short)	258
4/1	778
4/2	559
5/1	1400
6/1	484

Full Input Data And Results

Lane Saturation Flows

Junction: A441 / Dagnell End Road								
Lane	Lane Width (m)	Gradient	Nearside Lane	Allowed Turns	Turning Radius (m)	Turning Prop.	Sat Flow (PCU/Hr)	Flared Sat Flow (PCU/Hr)
1/1 (A441 Birmingham Rd (N))	3.50	0.00	Y	Arm 4 Ahead	Inf	77.5 %	1894	1894
1/2 (A441 Birmingham Rd (N))	3.50	0.00	N	Arm 4 Ahead	9.00	22.5 %	2105	2105
2/1 (Dagnell End Rd)	3.65	0.00	Y	Arm 4 Left	11.00	100.0 %	1742	1742
2/2 (Dagnell End Rd)	3.65	0.00	Y	Arm 5 Right	17.00	100.0 %	1819	1819
3/1 (A441 Birmingham Rd (S) Lane 1)	This lane uses a directly entered Saturation Flow						1726	1726
3/2 (A441 Birmingham Rd (S) Lane 2)	This lane uses a directly entered Saturation Flow						1679	1679
4/1 (S Exit Lane 1)	Infinite Saturation Flow						Inf	Inf
4/2 (S Exit Lane 2)	Infinite Saturation Flow						Inf	Inf
5/1 (N Exit Lane 1)	Infinite Saturation Flow						Inf	Inf
6/1 (E Exit Lane 1)	Infinite Saturation Flow						Inf	Inf

Scenario 4: '4' (FG4: '2030 PM Effective Base + Dev', Plan 1: 'Network Control Plan 1 (no Peds)')

Traffic Flows, Desired

Desired Flow :

	Destination				
		A	B	C	Tot.
Origin	A	0	187	1043	1230
	B	407	0	278	685
	C	1188	221	0	1409
	Tot.	1595	408	1321	3324

Full Input Data And Results

Traffic Lane Flows

Lane	Scenario 4: 4
Junction: A441 / Dagnell End Road	
1/1 (short)	947
1/2 (with short)	1230(In) 283(Out)
2/1 (short)	278
2/2 (with short)	685(In) 407(Out)
3/1 (with short)	1409(In) 1188(Out)
3/2 (short)	221
4/1	760
4/2	561
5/1	1595
6/1	408

Lane Saturation Flows

Junction: A441 / Dagnell End Road								
Lane	Lane Width (m)	Gradient	Nearside Lane	Allowed Turns	Turning Radius (m)	Turning Prop.	Sat Flow (PCU/Hr)	Flared Sat Flow (PCU/Hr)
1/1 (A441 Birmingham Rd (N))	3.50	0.00	Y	Arm 4 Ahead	Inf	80.3 %	1902	1902
				Arm 6 Left	9.00	19.7 %		
1/2 (A441 Birmingham Rd (N))	3.50	0.00	N	Arm 4 Ahead	Inf	100.0 %	2105	2105
2/1 (Dagnell End Rd)	3.65	0.00	Y	Arm 4 Left	11.00	100.0 %	1742	1742
2/2 (Dagnell End Rd)	3.65	0.00	Y	Arm 5 Right	17.00	100.0 %	1819	1819
3/1 (A441 Birmingham Rd (S) Lane 1)	This lane uses a directly entered Saturation Flow						1641	1641
3/2 (A441 Birmingham Rd (S) Lane 2)	This lane uses a directly entered Saturation Flow						1800	1800
4/1 (S Exit Lane 1)	Infinite Saturation Flow						Inf	Inf
4/2 (S Exit Lane 2)	Infinite Saturation Flow						Inf	Inf
5/1 (N Exit Lane 1)	Infinite Saturation Flow						Inf	Inf
6/1 (E Exit Lane 1)	Infinite Saturation Flow						Inf	Inf

Full Input Data And Results

Scenario 5: '5' (FG1: '2030 AM Effective Base', Plan 2: 'Network Control Plan 2 (no Peds, no left filter)')

Traffic Flows, Desired

Desired Flow :

		Destination			
		A	B	C	Tot.
Origin	A	0	206	1078	1284
	B	197	0	210	407
	C	1145	241	0	1386
	Tot.	1342	447	1288	3077

Traffic Lane Flows

Lane	Scenario 5: 5
Junction: A441 / Dagnell End Road	
1/1 (short)	989
1/2 (with short)	1284(In) 295(Out)
2/1 (short)	210
2/2 (with short)	407(In) 197(Out)
3/1 (with short)	1386(In) 1145(Out)
3/2 (short)	241
4/1	783
4/2	505
5/1	1342
6/1	447

Full Input Data And Results

Lane Saturation Flows

Junction: A441 / Dagnell End Road								
Lane	Lane Width (m)	Gradient	Nearside Lane	Allowed Turns	Turning Radius (m)	Turning Prop.	Sat Flow (PCU/Hr)	Flared Sat Flow (PCU/Hr)
1/1 (A441 Birmingham Rd (N))	3.50	0.00	Y	Arm 4 Ahead	Inf	79.2 %	1899	1899
1/2 (A441 Birmingham Rd (N))	3.50	0.00	N	Arm 4 Ahead	9.00	20.8 %	2105	2105
2/1 (Dagnell End Rd)	3.65	0.00	Y	Arm 4 Left	11.00	100.0 %	1742	1742
2/2 (Dagnell End Rd)	3.65	0.00	Y	Arm 5 Right	17.00	100.0 %	1819	1819
3/1 (A441 Birmingham Rd (S) Lane 1)	This lane uses a directly entered Saturation Flow						1726	1726
3/2 (A441 Birmingham Rd (S) Lane 2)	This lane uses a directly entered Saturation Flow						1679	1679
4/1 (S Exit Lane 1)	Infinite Saturation Flow						Inf	Inf
4/2 (S Exit Lane 2)	Infinite Saturation Flow						Inf	Inf
5/1 (N Exit Lane 1)	Infinite Saturation Flow						Inf	Inf
6/1 (E Exit Lane 1)	Infinite Saturation Flow						Inf	Inf

Scenario 6: '6' (FG2: '2030 PM Effective Base', Plan 2: 'Network Control Plan 2 (no Peds, no left filter)')

Traffic Flows, Desired

Desired Flow :

	Destination				
		A	B	C	Tot.
Origin	A	0	132	1043	1175
	B	379	0	255	634
	C	1188	175	0	1363
	Tot.	1567	307	1298	3172

Full Input Data And Results

Traffic Lane Flows

Lane	Scenario 6: 6
Junction: A441 / Dagnell End Road	
1/1 (short)	905
1/2 (with short)	1175(In) 270(Out)
2/1 (short)	255
2/2 (with short)	634(In) 379(Out)
3/1 (with short)	1363(In) 1188(Out)
3/2 (short)	175
4/1	773
4/2	525
5/1	1567
6/1	307

Lane Saturation Flows

Junction: A441 / Dagnell End Road								
Lane	Lane Width (m)	Gradient	Nearside Lane	Allowed Turns	Turning Radius (m)	Turning Prop.	Sat Flow (PCU/Hr)	Flared Sat Flow (PCU/Hr)
1/1 (A441 Birmingham Rd (N))	3.50	0.00	Y	Arm 4 Ahead	Inf	85.4 %	1918	1918
				Arm 6 Left	9.00	14.6 %		
1/2 (A441 Birmingham Rd (N))	3.50	0.00	N	Arm 4 Ahead	Inf	100.0 %	2105	2105
2/1 (Dagnell End Rd)	3.65	0.00	Y	Arm 4 Left	11.00	100.0 %	1742	1742
2/2 (Dagnell End Rd)	3.65	0.00	Y	Arm 5 Right	17.00	100.0 %	1819	1819
3/1 (A441 Birmingham Rd (S) Lane 1)	This lane uses a directly entered Saturation Flow						1641	1641
3/2 (A441 Birmingham Rd (S) Lane 2)	This lane uses a directly entered Saturation Flow						1800	1800
4/1 (S Exit Lane 1)	Infinite Saturation Flow						Inf	Inf
4/2 (S Exit Lane 2)	Infinite Saturation Flow						Inf	Inf
5/1 (N Exit Lane 1)	Infinite Saturation Flow						Inf	Inf
6/1 (E Exit Lane 1)	Infinite Saturation Flow						Inf	Inf

Full Input Data And Results

Scenario 7: '7' (FG3: '2030 AM Effective Base + Dev', Plan 2: 'Network Control Plan 2 (no Peds, no left filter)')

Traffic Flows, Desired

Desired Flow :

	Destination				
		A	B	C	Tot.
Origin	A	0	226	1078	1304
	B	255	0	259	514
	C	1145	258	0	1403
	Tot.	1400	484	1337	3221

Traffic Lane Flows

Lane	Scenario 7: 7
Junction: A441 / Dagnell End Road	
1/1 (short)	1004
1/2 (with short)	1304(In) 300(Out)
2/1 (short)	259
2/2 (with short)	514(In) 255(Out)
3/1 (with short)	1403(In) 1145(Out)
3/2 (short)	258
4/1	778
4/2	559
5/1	1400
6/1	484

Full Input Data And Results

Lane Saturation Flows

Junction: A441 / Dagnell End Road								
Lane	Lane Width (m)	Gradient	Nearside Lane	Allowed Turns	Turning Radius (m)	Turning Prop.	Sat Flow (PCU/Hr)	Flared Sat Flow (PCU/Hr)
1/1 (A441 Birmingham Rd (N))	3.50	0.00	Y	Arm 4 Ahead	Inf	77.5 %	1894	1894
1/2 (A441 Birmingham Rd (N))	3.50	0.00	N	Arm 4 Ahead	9.00	22.5 %	2105	2105
2/1 (Dagnell End Rd)	3.65	0.00	Y	Arm 4 Left	11.00	100.0 %	1742	1742
2/2 (Dagnell End Rd)	3.65	0.00	Y	Arm 5 Right	17.00	100.0 %	1819	1819
3/1 (A441 Birmingham Rd (S) Lane 1)	This lane uses a directly entered Saturation Flow						1726	1726
3/2 (A441 Birmingham Rd (S) Lane 2)	This lane uses a directly entered Saturation Flow						1679	1679
4/1 (S Exit Lane 1)	Infinite Saturation Flow						Inf	Inf
4/2 (S Exit Lane 2)	Infinite Saturation Flow						Inf	Inf
5/1 (N Exit Lane 1)	Infinite Saturation Flow						Inf	Inf
6/1 (E Exit Lane 1)	Infinite Saturation Flow						Inf	Inf

Scenario 8: '8' (FG4: '2030 PM Effective Base + Dev', Plan 2: 'Network Control Plan 2 (no Peds, no left filter)')

Traffic Flows, Desired

Desired Flow :

	Destination				
		A	B	C	Tot.
Origin	A	0	187	1043	1230
	B	407	0	278	685
	C	1188	221	0	1409
	Tot.	1595	408	1321	3324

Full Input Data And Results

Traffic Lane Flows

Lane	Scenario 8: 8
Junction: A441 / Dagnell End Road	
1/1 (short)	947
1/2 (with short)	1230(In) 283(Out)
2/1 (short)	278
2/2 (with short)	685(In) 407(Out)
3/1 (with short)	1409(In) 1188(Out)
3/2 (short)	221
4/1	760
4/2	561
5/1	1595
6/1	408

Lane Saturation Flows

Junction: A441 / Dagnell End Road								
Lane	Lane Width (m)	Gradient	Nearside Lane	Allowed Turns	Turning Radius (m)	Turning Prop.	Sat Flow (PCU/Hr)	Flared Sat Flow (PCU/Hr)
1/1 (A441 Birmingham Rd (N))	3.50	0.00	Y	Arm 4 Ahead	Inf	80.3 %	1902	1902
				Arm 6 Left	9.00	19.7 %		
1/2 (A441 Birmingham Rd (N))	3.50	0.00	N	Arm 4 Ahead	Inf	100.0 %	2105	2105
2/1 (Dagnell End Rd)	3.65	0.00	Y	Arm 4 Left	11.00	100.0 %	1742	1742
2/2 (Dagnell End Rd)	3.65	0.00	Y	Arm 5 Right	17.00	100.0 %	1819	1819
3/1 (A441 Birmingham Rd (S) Lane 1)	This lane uses a directly entered Saturation Flow						1641	1641
3/2 (A441 Birmingham Rd (S) Lane 2)	This lane uses a directly entered Saturation Flow						1800	1800
4/1 (S Exit Lane 1)	Infinite Saturation Flow						Inf	Inf
4/2 (S Exit Lane 2)	Infinite Saturation Flow						Inf	Inf
5/1 (N Exit Lane 1)	Infinite Saturation Flow						Inf	Inf
6/1 (E Exit Lane 1)	Infinite Saturation Flow						Inf	Inf

Full Input Data And Results

Scenario 9: '9' (FG1: '2030 AM Effective Base', Plan 3: 'Network Control Plan 3 (Peds)')

Traffic Flows, Desired

Desired Flow :

		Destination			
		A	B	C	Tot.
Origin	A	0	206	1078	1284
	B	197	0	210	407
	C	1145	241	0	1386
	Tot.	1342	447	1288	3077

Traffic Lane Flows

Lane	Scenario 9: 9
Junction: A441 / Dagnell End Road	
1/1 (short)	989
1/2 (with short)	1284(In) 295(Out)
2/1 (short)	210
2/2 (with short)	407(In) 197(Out)
3/1 (with short)	1386(In) 1145(Out)
3/2 (short)	241
4/1	783
4/2	505
5/1	1342
6/1	447

Full Input Data And Results

Lane Saturation Flows

Junction: A441 / Dagnell End Road								
Lane	Lane Width (m)	Gradient	Nearside Lane	Allowed Turns	Turning Radius (m)	Turning Prop.	Sat Flow (PCU/Hr)	Flared Sat Flow (PCU/Hr)
1/1 (A441 Birmingham Rd (N))	3.50	0.00	Y	Arm 4 Ahead	Inf	79.2 %	1899	1899
1/2 (A441 Birmingham Rd (N))	3.50	0.00	N	Arm 6 Left Arm 4 Ahead	9.00	20.8 %	2105	2105
2/1 (Dagnell End Rd)	3.65	0.00	Y	Arm 4 Left	11.00	100.0 %	1742	1742
2/2 (Dagnell End Rd)	3.65	0.00	Y	Arm 5 Right	17.00	100.0 %	1819	1819
3/1 (A441 Birmingham Rd (S) Lane 1)	This lane uses a directly entered Saturation Flow						1726	1726
3/2 (A441 Birmingham Rd (S) Lane 2)	This lane uses a directly entered Saturation Flow						1679	1679
4/1 (S Exit Lane 1)	Infinite Saturation Flow						Inf	Inf
4/2 (S Exit Lane 2)	Infinite Saturation Flow						Inf	Inf
5/1 (N Exit Lane 1)	Infinite Saturation Flow						Inf	Inf
6/1 (E Exit Lane 1)	Infinite Saturation Flow						Inf	Inf

Scenario 10: '10' (FG2: '2030 PM Effective Base', Plan 3: 'Network Control Plan 3 (Peds)')

Traffic Flows, Desired

Desired Flow :

	Destination				
		A	B	C	Tot.
Origin	A	0	132	1043	1175
	B	379	0	255	634
	C	1188	175	0	1363
	Tot.	1567	307	1298	3172

Full Input Data And Results

Traffic Lane Flows

Lane	Scenario 10: 10
Junction: A441 / Dagnell End Road	
1/1 (short)	905
1/2 (with short)	1175(In) 270(Out)
2/1 (short)	255
2/2 (with short)	634(In) 379(Out)
3/1 (with short)	1363(In) 1188(Out)
3/2 (short)	175
4/1	773
4/2	525
5/1	1567
6/1	307

Lane Saturation Flows

Junction: A441 / Dagnell End Road								
Lane	Lane Width (m)	Gradient	Nearside Lane	Allowed Turns	Turning Radius (m)	Turning Prop.	Sat Flow (PCU/Hr)	Flared Sat Flow (PCU/Hr)
1/1 (A441 Birmingham Rd (N))	3.50	0.00	Y	Arm 4 Ahead	Inf	85.4 %	1918	1918
				Arm 6 Left	9.00	14.6 %		
1/2 (A441 Birmingham Rd (N))	3.50	0.00	N	Arm 4 Ahead	Inf	100.0 %	2105	2105
2/1 (Dagnell End Rd)	3.65	0.00	Y	Arm 4 Left	11.00	100.0 %	1742	1742
2/2 (Dagnell End Rd)	3.65	0.00	Y	Arm 5 Right	17.00	100.0 %	1819	1819
3/1 (A441 Birmingham Rd (S) Lane 1)	This lane uses a directly entered Saturation Flow						1641	1641
3/2 (A441 Birmingham Rd (S) Lane 2)	This lane uses a directly entered Saturation Flow						1800	1800
4/1 (S Exit Lane 1)	Infinite Saturation Flow						Inf	Inf
4/2 (S Exit Lane 2)	Infinite Saturation Flow						Inf	Inf
5/1 (N Exit Lane 1)	Infinite Saturation Flow						Inf	Inf
6/1 (E Exit Lane 1)	Infinite Saturation Flow						Inf	Inf

Full Input Data And Results

Scenario 11: '11' (FG3: '2030 AM Effective Base + Dev', Plan 3: 'Network Control Plan 3 (Peds)')

Traffic Flows, Desired

Desired Flow :

		Destination			
		A	B	C	Tot.
Origin	A	0	226	1078	1304
	B	255	0	259	514
	C	1145	258	0	1403
	Tot.	1400	484	1337	3221

Traffic Lane Flows

Lane	Scenario 11: 11
Junction: A441 / Dagnell End Road	
1/1 (short)	1004
1/2 (with short)	1304(In) 300(Out)
2/1 (short)	259
2/2 (with short)	514(In) 255(Out)
3/1 (with short)	1403(In) 1145(Out)
3/2 (short)	258
4/1	778
4/2	559
5/1	1400
6/1	484

Lane Saturation Flows

Junction: A441 / Dagnell End Road								
Lane	Lane Width (m)	Gradient	Nearside Lane	Allowed Turns	Turning Radius (m)	Turning Prop.	Sat Flow (PCU/Hr)	Flared Sat Flow (PCU/Hr)
1/1 (A441 Birmingham Rd (N))	3.50	0.00	Y	Arm 4 Ahead	Inf	77.5 %	1894	1894
1/2 (A441 Birmingham Rd (N))	3.50	0.00	N	Arm 4 Ahead	9.00	22.5 %	2105	2105
2/1 (Dagnell End Rd)	3.65	0.00	Y	Arm 4 Left	11.00	100.0 %	1742	1742
2/2 (Dagnell End Rd)	3.65	0.00	Y	Arm 5 Right	17.00	100.0 %	1819	1819
3/1 (A441 Birmingham Rd (S) Lane 1)	This lane uses a directly entered Saturation Flow						1726	1726
3/2 (A441 Birmingham Rd (S) Lane 2)	This lane uses a directly entered Saturation Flow						1679	1679
4/1 (S Exit Lane 1)	Infinite Saturation Flow						Inf	Inf
4/2 (S Exit Lane 2)	Infinite Saturation Flow						Inf	Inf
5/1 (N Exit Lane 1)	Infinite Saturation Flow						Inf	Inf
6/1 (E Exit Lane 1)	Infinite Saturation Flow						Inf	Inf

Scenario 12: '12' (FG4: '2030 PM Effective Base + Dev', Plan 3: 'Network Control Plan 3 (Peds)')

Traffic Flows, Desired

Desired Flow :

	Destination				
		A	B	C	Tot.
Origin	A	0	187	1043	1230
	B	407	0	278	685
	C	1188	221	0	1409
	Tot.	1595	408	1321	3324

Full Input Data And Results

Traffic Lane Flows

Lane	Scenario 12: 12
Junction: A441 / Dagnell End Road	
1/1 (short)	947
1/2 (with short)	1230(In) 283(Out)
2/1 (short)	278
2/2 (with short)	685(In) 407(Out)
3/1 (with short)	1409(In) 1188(Out)
3/2 (short)	221
4/1	760
4/2	561
5/1	1595
6/1	408

Lane Saturation Flows

Junction: A441 / Dagnell End Road								
Lane	Lane Width (m)	Gradient	Nearside Lane	Allowed Turns	Turning Radius (m)	Turning Prop.	Sat Flow (PCU/Hr)	Flared Sat Flow (PCU/Hr)
1/1 (A441 Birmingham Rd (N))	3.50	0.00	Y	Arm 4 Ahead	Inf	80.3 %	1902	1902
				Arm 6 Left	9.00	19.7 %		
1/2 (A441 Birmingham Rd (N))	3.50	0.00	N	Arm 4 Ahead	Inf	100.0 %	2105	2105
2/1 (Dagnell End Rd)	3.65	0.00	Y	Arm 4 Left	11.00	100.0 %	1742	1742
2/2 (Dagnell End Rd)	3.65	0.00	Y	Arm 5 Right	17.00	100.0 %	1819	1819
3/1 (A441 Birmingham Rd (S) Lane 1)	This lane uses a directly entered Saturation Flow						1641	1641
3/2 (A441 Birmingham Rd (S) Lane 2)	This lane uses a directly entered Saturation Flow						1800	1800
4/1 (S Exit Lane 1)	Infinite Saturation Flow						Inf	Inf
4/2 (S Exit Lane 2)	Infinite Saturation Flow						Inf	Inf
5/1 (N Exit Lane 1)	Infinite Saturation Flow						Inf	Inf
6/1 (E Exit Lane 1)	Infinite Saturation Flow						Inf	Inf

Full Input Data And Results

Scenario 1: '1' (FG1: '2030 AM Effective Base', Plan 1: 'Network Control Plan 1 (no Peds)')

Stage Sequence Diagram

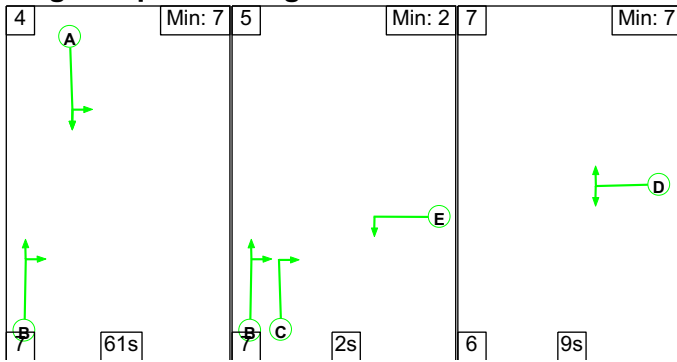

Stage Timings

Stage	4	5	7
Duration	61	2	9
Change Point	0	68	77

Signal Timings Diagram

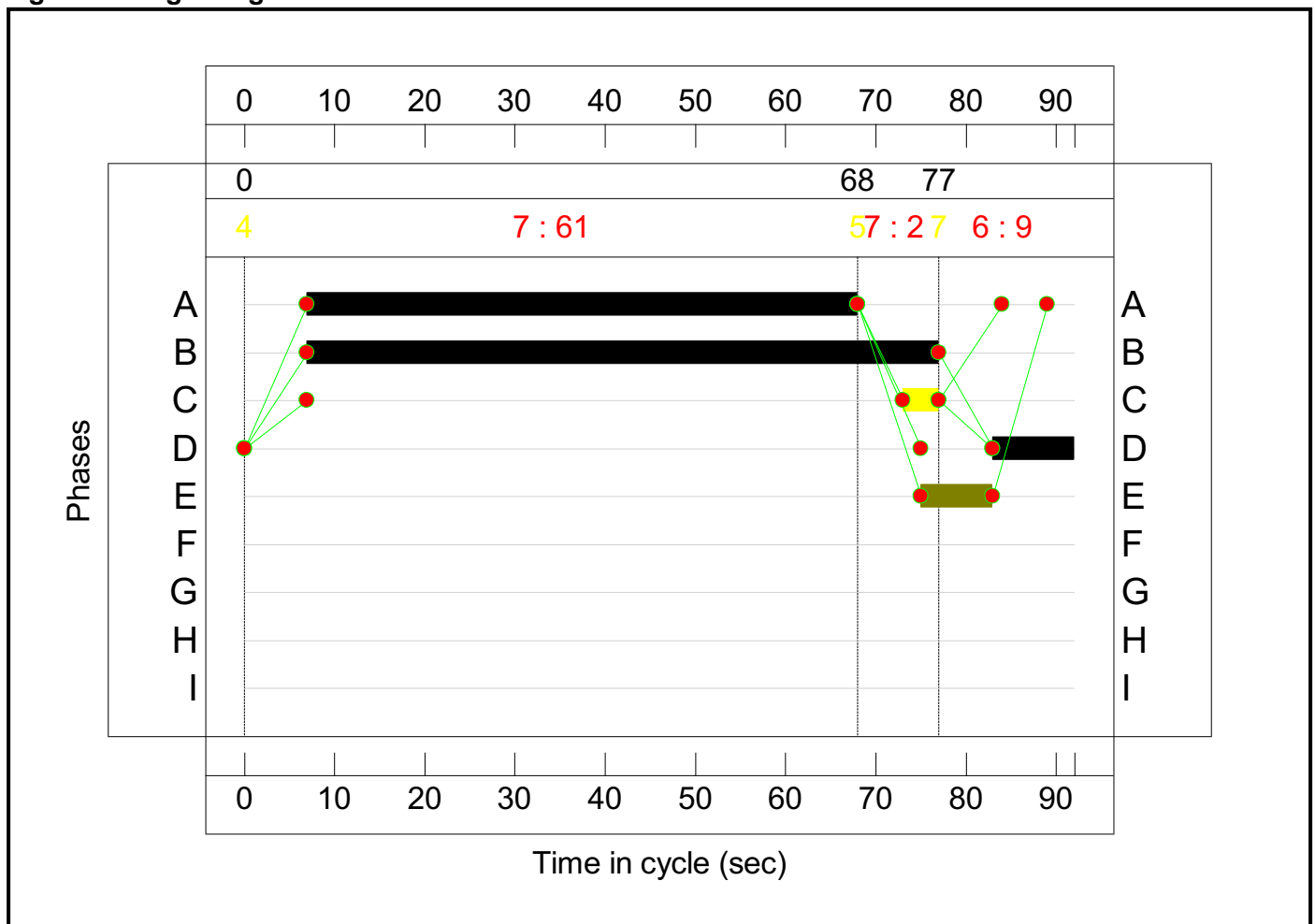

Network Layout Diagram

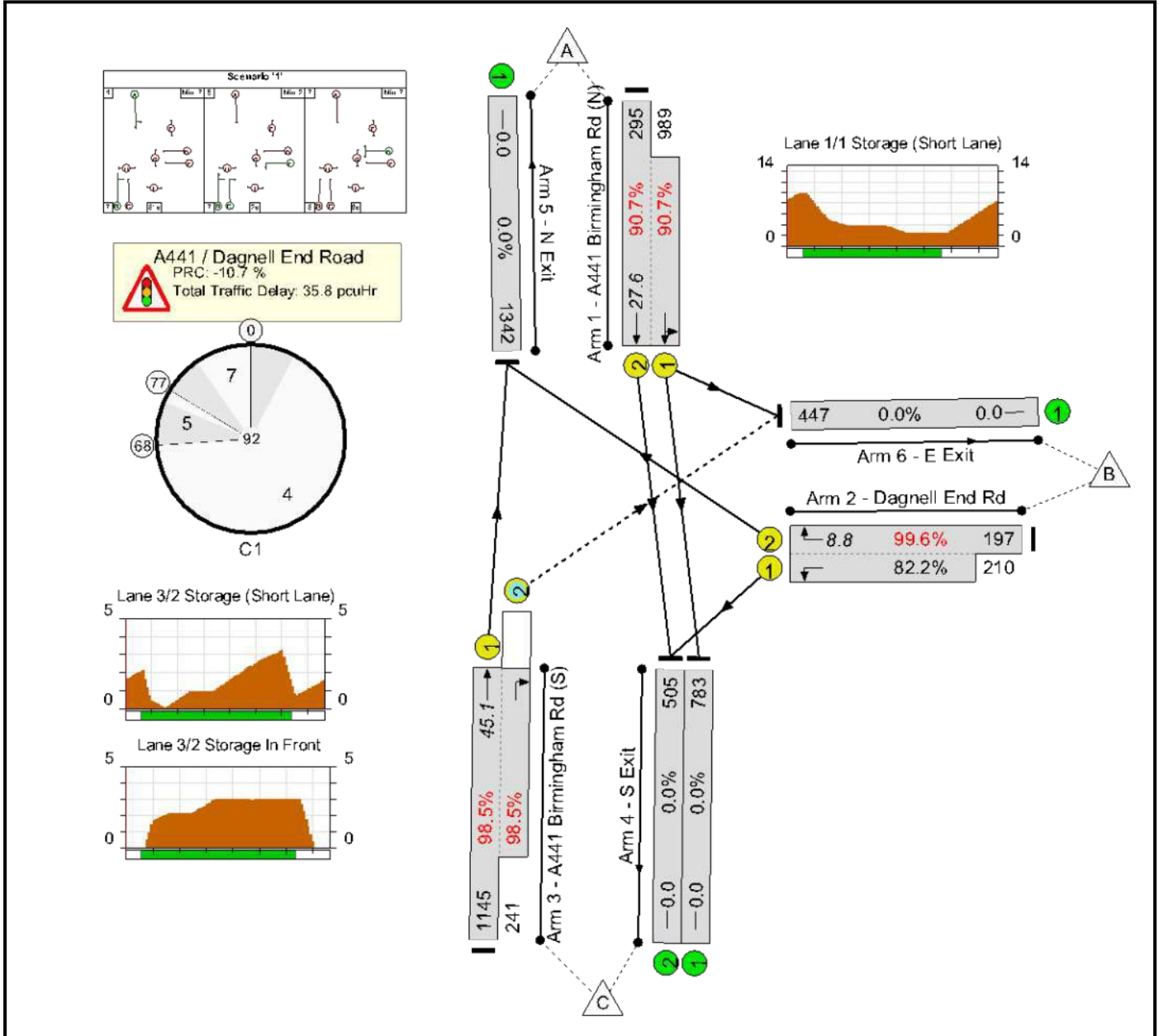

Full Input Data And Results

Network Results

Item	Lane Description	Lane Type	Controller Stream	Position In Filtered Route	Full Phase	Arrow Phase	Num Greens	Total Green (s)	Arrow Green (s)	Demand Flow (pcu)	Sat Flow (pcu/Hr)	Capacity (pcu)	Deg Sat (%)
Network: A441 / Dagnell End Road	-	-	N/A	-	-		-	-	-	-	-	-	99.6%
A441 / Dagnell End Road	-	-	N/A	-	-		-	-	-	-	-	-	99.6%
1/2+1/1	A441 Birmingham Rd (N) Ahead Left	U	N/A	N/A	A		1	61	-	1284	2105:1899	325+1091	90.7 : 90.7%
2/2+2/1	Dagnell End Rd Left Right	U	N/A	N/A	D	E	1	9:17	8	407	1819:1742	198+256	99.6 : 82.2%
3/1+3/2	A441 Birmingham Rd (S) Ahead Right	U+O	N/A	N/A	B	C	1	70	4	1386	1726:1679	1162+245	98.5 : 98.5%
4/1	S Exit	U	N/A	N/A	-		-	-	-	783	Inf	Inf	0.0%
4/2	S Exit	U	N/A	N/A	-		-	-	-	505	Inf	Inf	0.0%
5/1	N Exit	U	N/A	N/A	-		-	-	-	1342	Inf	Inf	0.0%
6/1	E Exit	U	N/A	N/A	-		-	-	-	447	Inf	Inf	0.0%

Full Input Data And Results

Item	Arriving (pcu)	Leaving (pcu)	Turners In Gaps (pcu)	Turners When Unopposed (pcu)	Turners In Intergreen (pcu)	Uniform Delay (pcuHr)	Rand + Oversat Delay (pcuHr)	Storage Area Uniform Delay (pcuHr)	Total Delay (pcuHr)	Av. Delay Per PCU (s/pcu)	Max. Back of Uniform Queue (pcu)	Rand + Oversat Queue (pcu)	Mean Max Queue (pcu)
Network: A441 / Dagnell End Road	-	-	8	128	106	11.5	22.4	1.9	35.8	-	-	-	-
A441 / Dagnell End Road	-	-	8	128	106	11.5	22.4	1.9	35.8	-	-	-	-
1/2+1/1	1284	1284	-	-	-	3.7	4.5	-	8.2 (1.7+6.5)	23.1 (21.0:23.7)	23.1	4.5	27.6
2/2+2/1	407	407	-	-	-	4.2	3.8	-	8.0 (4.1+3.9)	70.8 (74.4:67.3)	5.0	3.8	8.8
3/1+3/2	1386	1386	8	128	106	3.6	14.1	1.9	19.6 (14.3+5.3)	50.8 (45.0:78.4)	31.0	14.1	45.1
4/1	783	783	-	-	-	0.0	0.0	-	0.0	0.0	0.0	0.0	0.0
4/2	505	505	-	-	-	0.0	0.0	-	0.0	0.0	0.0	0.0	0.0
5/1	1342	1342	-	-	-	0.0	0.0	-	0.0	0.0	0.0	0.0	0.0
6/1	447	447	-	-	-	0.0	0.0	-	0.0	0.0	0.0	0.0	0.0
C1 PRC for Signalled Lanes (%): -10.7 Total Delay for Signalled Lanes (pcuHr): 35.81 Cycle Time (s): 92 PRC Over All Lanes (%): -10.7 Total Delay Over All Lanes(pcuHr): 35.81													

Full Input Data And Results

Scenario 2: '2' (FG2: '2030 PM Effective Base', Plan 1: 'Network Control Plan 1 (no Peds)')

Stage Sequence Diagram

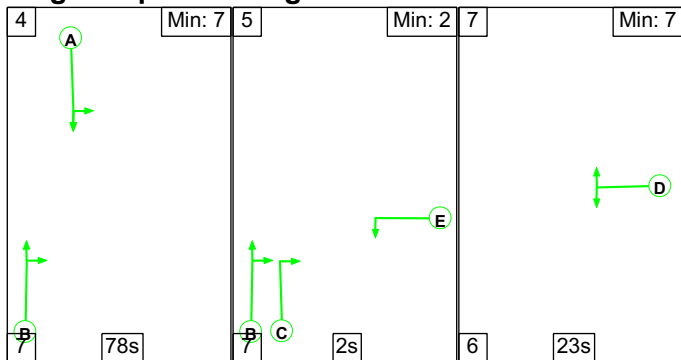

Stage Timings

Stage	4	5	7
Duration	78	2	23
Change Point	0	85	94

Signal Timings Diagram

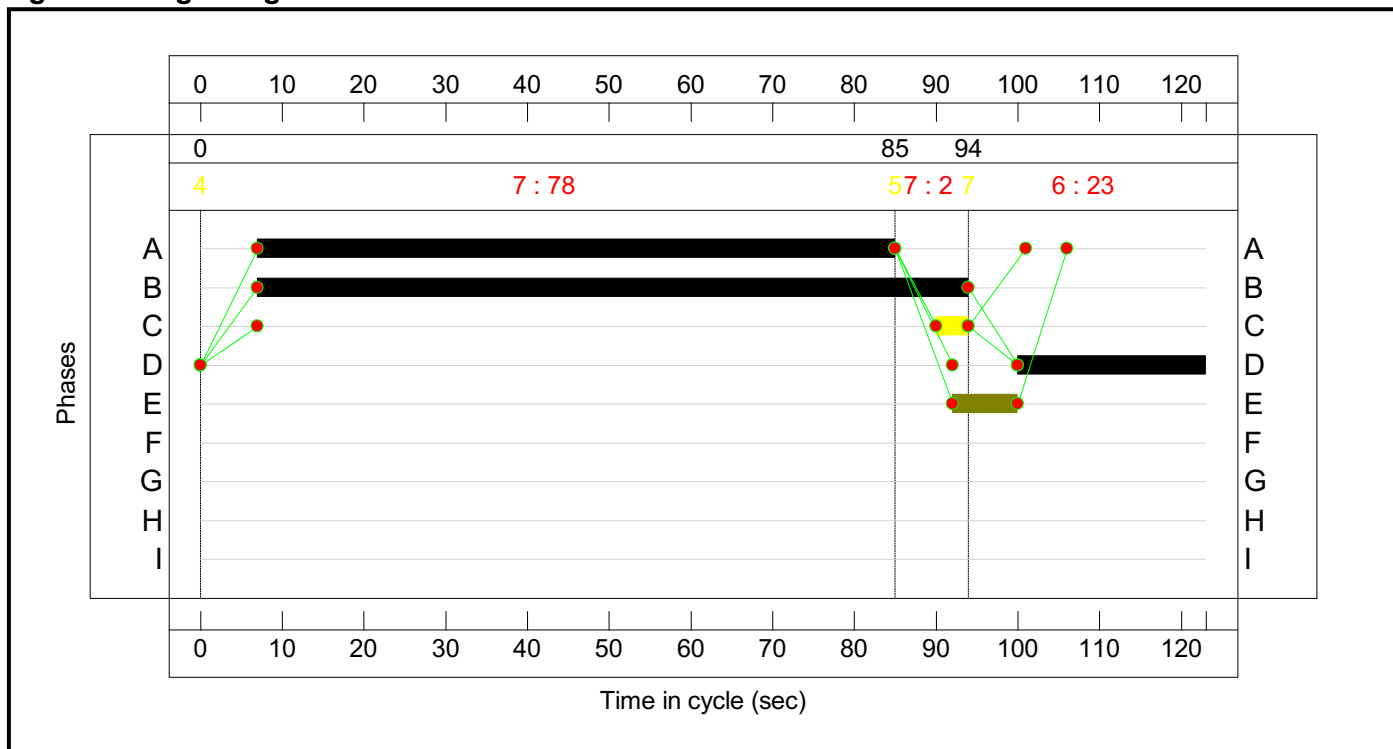

Network Layout Diagram

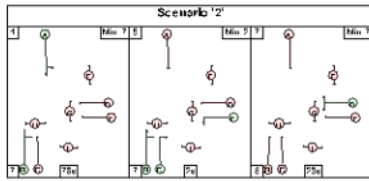

A441 / Dagnell End Road
 PRC: -24.1 %
 Total Traffic Delay: 145.6 pcuHr

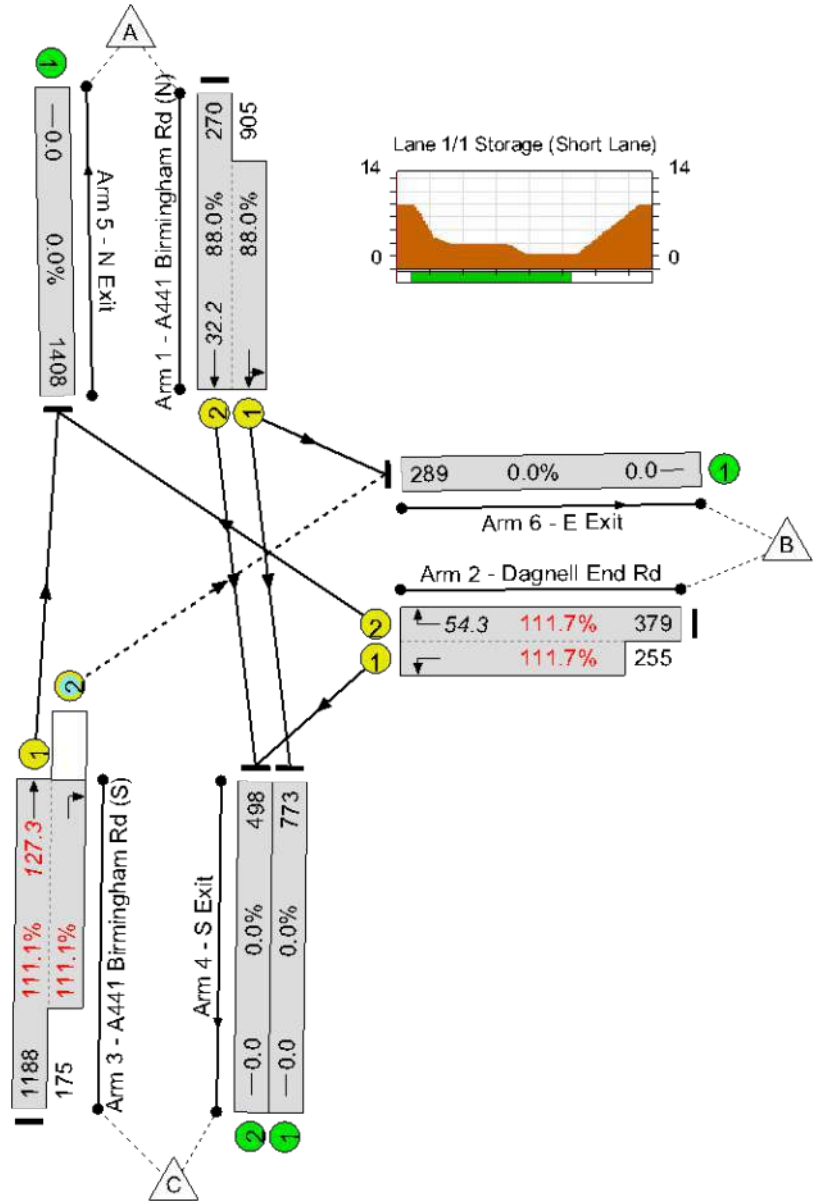
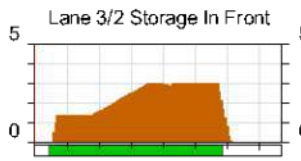
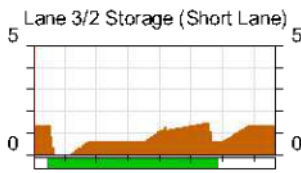
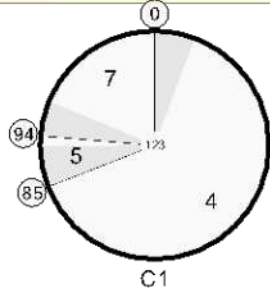

Full Input Data And Results

Network Results

Item	Lane Description	Lane Type	Controller Stream	Position In Filtered Route	Full Phase	Arrow Phase	Num Greens	Total Green (s)	Arrow Green (s)	Demand Flow (pcu)	Sat Flow (pcu/Hr)	Capacity (pcu)	Deg Sat (%)
Network: A441 / Dagnell End Road	-	-	N/A	-	-		-	-	-	-	-	-	111.7%
A441 / Dagnell End Road	-	-	N/A	-	-		-	-	-	-	-	-	111.7%
1/2+1/1	A441 Birmingham Rd (N) Ahead Left	U	N/A	N/A	A		1	78	-	1175	2105:1918	307+1028	88.0 : 88.0%
2/2+2/1	Dagnell End Rd Left Right	U	N/A	N/A	D	E	1	23:31	8	634	1819:1742	339+228	111.7 : 111.7%
3/1+3/2	A441 Birmingham Rd (S) Ahead Right	U+O	N/A	N/A	B	C	1	87	4	1363	1641:1800	1069+157	111.1 : 111.1%
4/1	S Exit	U	N/A	N/A	-		-	-	-	773	Inf	Inf	0.0%
4/2	S Exit	U	N/A	N/A	-		-	-	-	525	Inf	Inf	0.0%
5/1	N Exit	U	N/A	N/A	-		-	-	-	1567	Inf	Inf	0.0%
6/1	E Exit	U	N/A	N/A	-		-	-	-	307	Inf	Inf	0.0%

Full Input Data And Results

Item	Arriving (pcu)	Leaving (pcu)	Turners In Gaps (pcu)	Turners When Unopposed (pcu)	Turners In Intergreen (pcu)	Uniform Delay (pcuHr)	Rand + Oversat Delay (pcuHr)	Storage Area Uniform Delay (pcuHr)	Total Delay (pcuHr)	Av. Delay Per PCU (s/pcu)	Max. Back of Uniform Queue (pcu)	Rand + Oversat Queue (pcu)	Mean Max Queue (pcu)
Network: A441 / Dagnell End Road	-	-	32	102	23	30.2	113.9	1.5	145.6	-	-	-	-
A441 / Dagnell End Road	-	-	32	102	23	30.2	113.9	1.5	145.6	-	-	-	-
1/2+1/1	1175	1175	-	-	-	5.1	3.5	-	8.7 (1.9+6.8)	26.5 (24.7:27.1)	28.7	3.5	32.2
2/2+2/1	634	568	-	-	-	11.4	37.4	-	48.8 (29.5+19.3)	277.1 (280.3:272.2)	16.9	37.4	54.3
3/1+3/2	1363	1226	32	102	23	13.7	73.0	1.5	88.1 (75.4+12.7)	232.7 (228.6:260.5)	54.3	73.0	127.3
4/1	773	773	-	-	-	0.0	0.0	-	0.0	0.0	0.0	0.0	0.0
4/2	498	498	-	-	-	0.0	0.0	-	0.0	0.0	0.0	0.0	0.0
5/1	1408	1408	-	-	-	0.0	0.0	-	0.0	0.0	0.0	0.0	0.0
6/1	289	289	-	-	-	0.0	0.0	-	0.0	0.0	0.0	0.0	0.0
C1 PRC for Signalled Lanes (%): -24.1 Total Delay for Signalled Lanes (pcuHr): 145.56 Cycle Time (s): 123 PRC Over All Lanes (%): -24.1 Total Delay Over All Lanes(pcuHr): 145.56													

Full Input Data And Results

Scenario 3: '3' (FG3: '2030 AM Effective Base + Dev', Plan 1: 'Network Control Plan 1 (no Peds)')

Stage Sequence Diagram

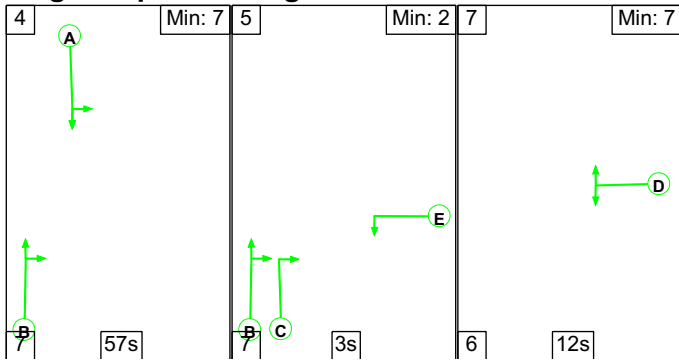

Stage Timings

Stage	4	5	7
Duration	57	3	12
Change Point	0	64	74

Signal Timings Diagram

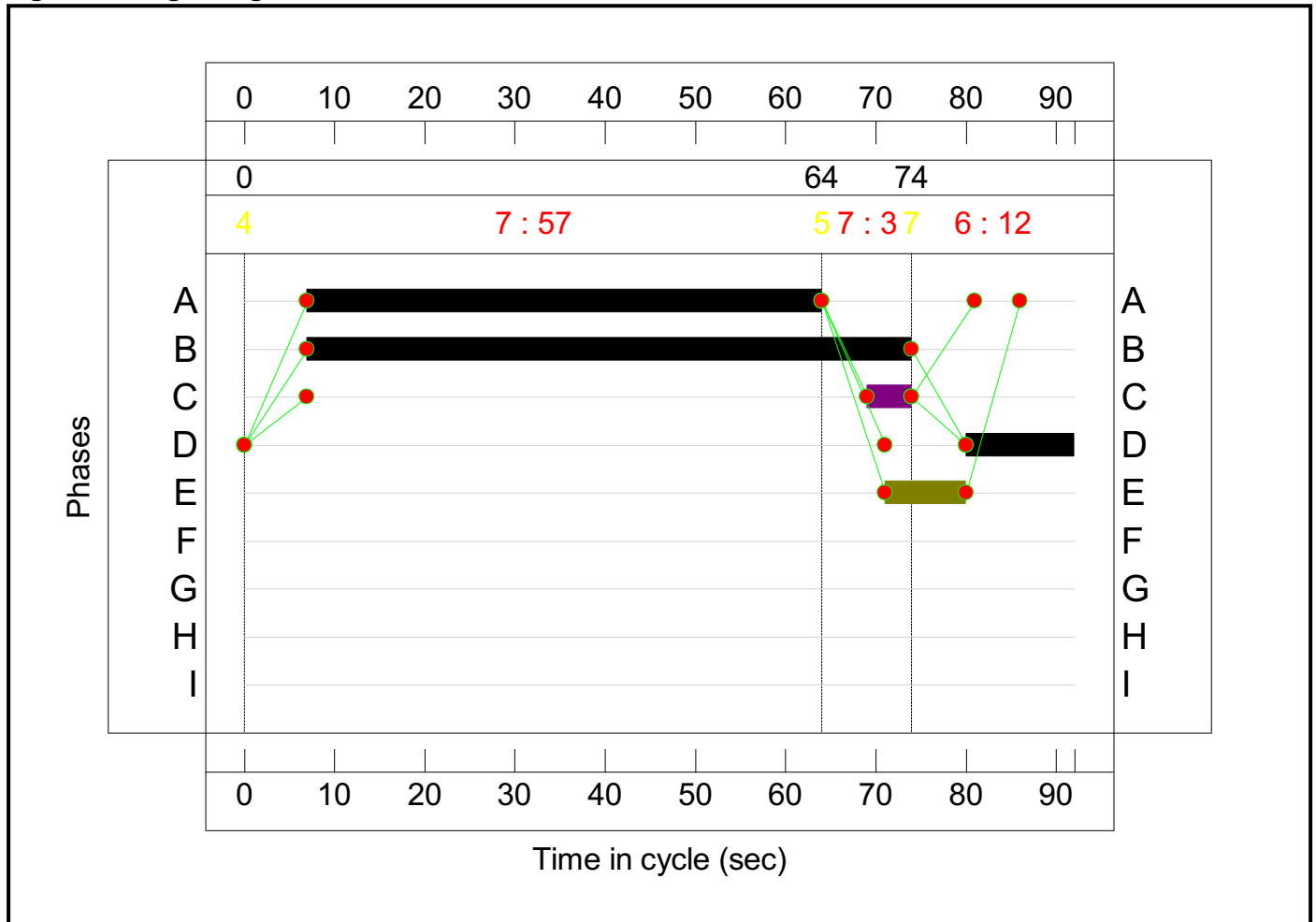

Network Layout Diagram

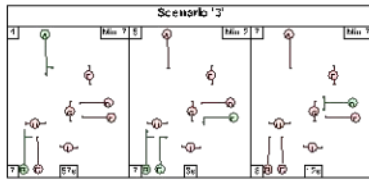

A441 / Dagnell End Road
 PRC: -14.9 %
 Total Traffic Delay: 74.9 pcu·hr

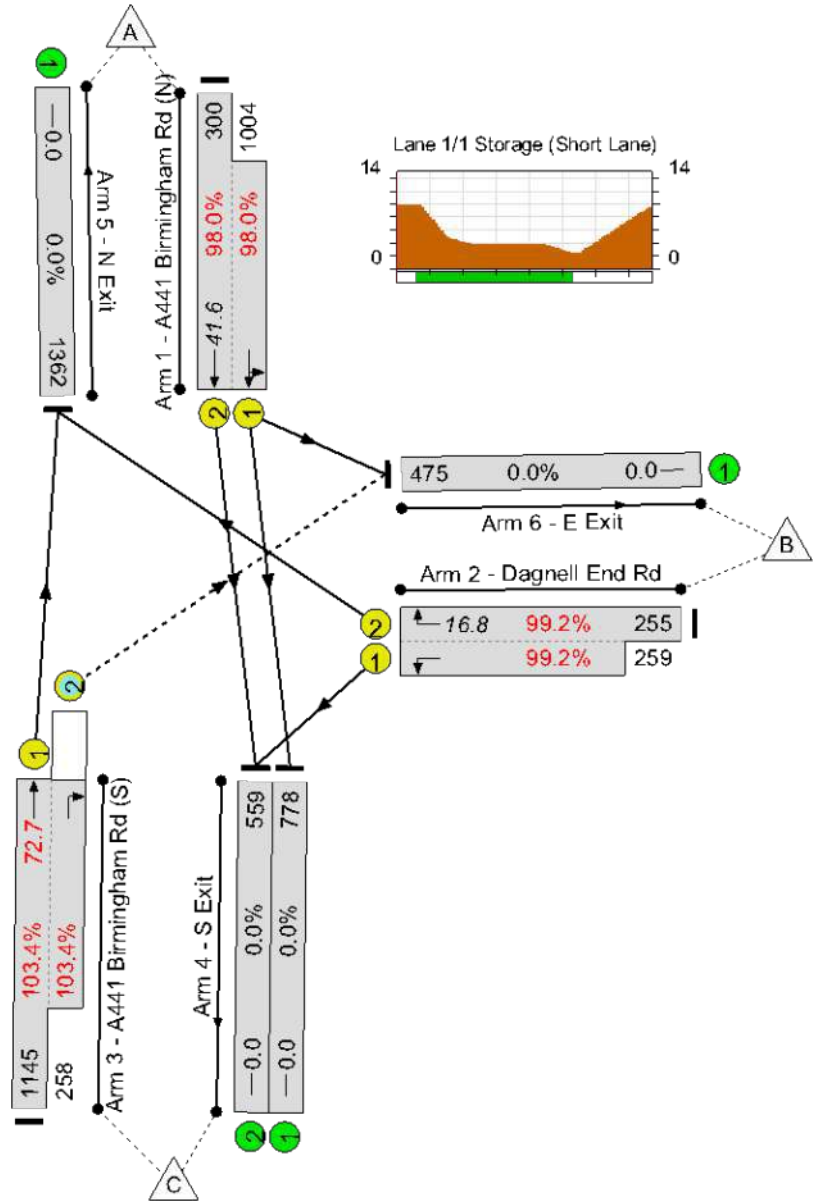
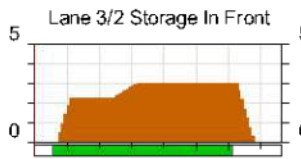
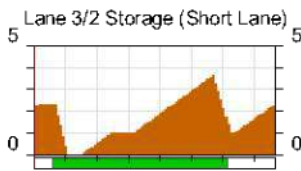
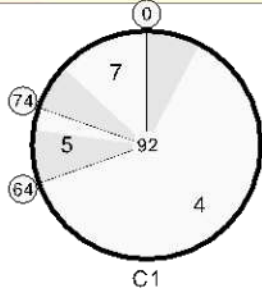

Full Input Data And Results

Network Results

Item	Lane Description	Lane Type	Controller Stream	Position In Filtered Route	Full Phase	Arrow Phase	Num Greens	Total Green (s)	Arrow Green (s)	Demand Flow (pcu)	Sat Flow (pcu/Hr)	Capacity (pcu)	Deg Sat (%)
Network: A441 / Dagnell End Road	-	-	N/A	-	-		-	-	-	-	-	-	103.4%
A441 / Dagnell End Road	-	-	N/A	-	-		-	-	-	-	-	-	103.4%
1/2+1/1	A441 Birmingham Rd (N) Ahead Left	U	N/A	N/A	A		1	57	-	1304	2105:1894	306+1024	98.0 : 98.0%
2/2+2/1	Dagnell End Rd Left Right	U	N/A	N/A	D	E	1	12:21	9	514	1819:1742	257+261	99.2 : 99.2%
3/1+3/2	A441 Birmingham Rd (S) Ahead Right	U+O	N/A	N/A	B	C	1	67	5	1403	1726:1679	1107+249	103.4 : 103.4%
4/1	S Exit	U	N/A	N/A	-		-	-	-	778	Inf	Inf	0.0%
4/2	S Exit	U	N/A	N/A	-		-	-	-	559	Inf	Inf	0.0%
5/1	N Exit	U	N/A	N/A	-		-	-	-	1400	Inf	Inf	0.0%
6/1	E Exit	U	N/A	N/A	-		-	-	-	484	Inf	Inf	0.0%

Full Input Data And Results

Item	Arriving (pcu)	Leaving (pcu)	Turners In Gaps (pcu)	Turners When Unopposed (pcu)	Turners In Intergreen (pcu)	Uniform Delay (pcuHr)	Rand + Oversat Delay (pcuHr)	Storage Area Uniform Delay (pcuHr)	Total Delay (pcuHr)	Av. Delay Per PCU (s/pcu)	Max. Back of Uniform Queue (pcu)	Rand + Oversat Queue (pcu)	Mean Max Queue (pcu)
Network: A441 / Dagnell End Road	-	-	1	146	103	16.5	56.6	1.8	74.9	-	-	-	-
A441 / Dagnell End Road	-	-	1	146	103	16.5	56.6	1.8	74.9	-	-	-	-
1/2+1/1	1304	1304	-	-	-	5.1	12.7	-	17.8 (3.9+13.9)	49.2 (47.1:49.8)	28.9	12.7	41.6
2/2+2/1	514	514	-	-	-	5.0	10.4	-	15.4 (7.9+7.5)	107.9 (112.0:103.8)	6.4	10.4	16.8
3/1+3/2	1403	1357	1	146	103	6.3	33.6	1.8	41.7 (32.2+9.4)	106.9 (101.4:131.7)	39.1	33.6	72.7
4/1	778	778	-	-	-	0.0	0.0	-	0.0	0.0	0.0	0.0	0.0
4/2	559	559	-	-	-	0.0	0.0	-	0.0	0.0	0.0	0.0	0.0
5/1	1362	1362	-	-	-	0.0	0.0	-	0.0	0.0	0.0	0.0	0.0
6/1	475	475	-	-	-	0.0	0.0	-	0.0	0.0	0.0	0.0	0.0
C1 PRC for Signalled Lanes (%): -14.9 Total Delay for Signalled Lanes (pcuHr): 74.90 Cycle Time (s): 92 PRC Over All Lanes (%): -14.9 Total Delay Over All Lanes(pcuHr): 74.90													

Full Input Data And Results

Scenario 4: '4' (FG4: '2030 PM Effective Base + Dev', Plan 1: 'Network Control Plan 1 (no Peds)')

Stage Sequence Diagram

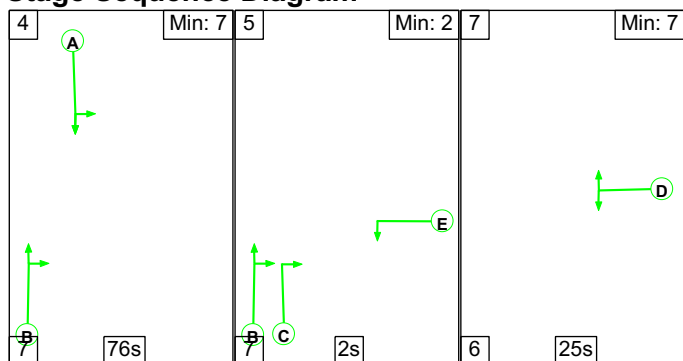

Stage Timings

Stage	4	5	7
Duration	76	2	25
Change Point	0	83	92

Signal Timings Diagram

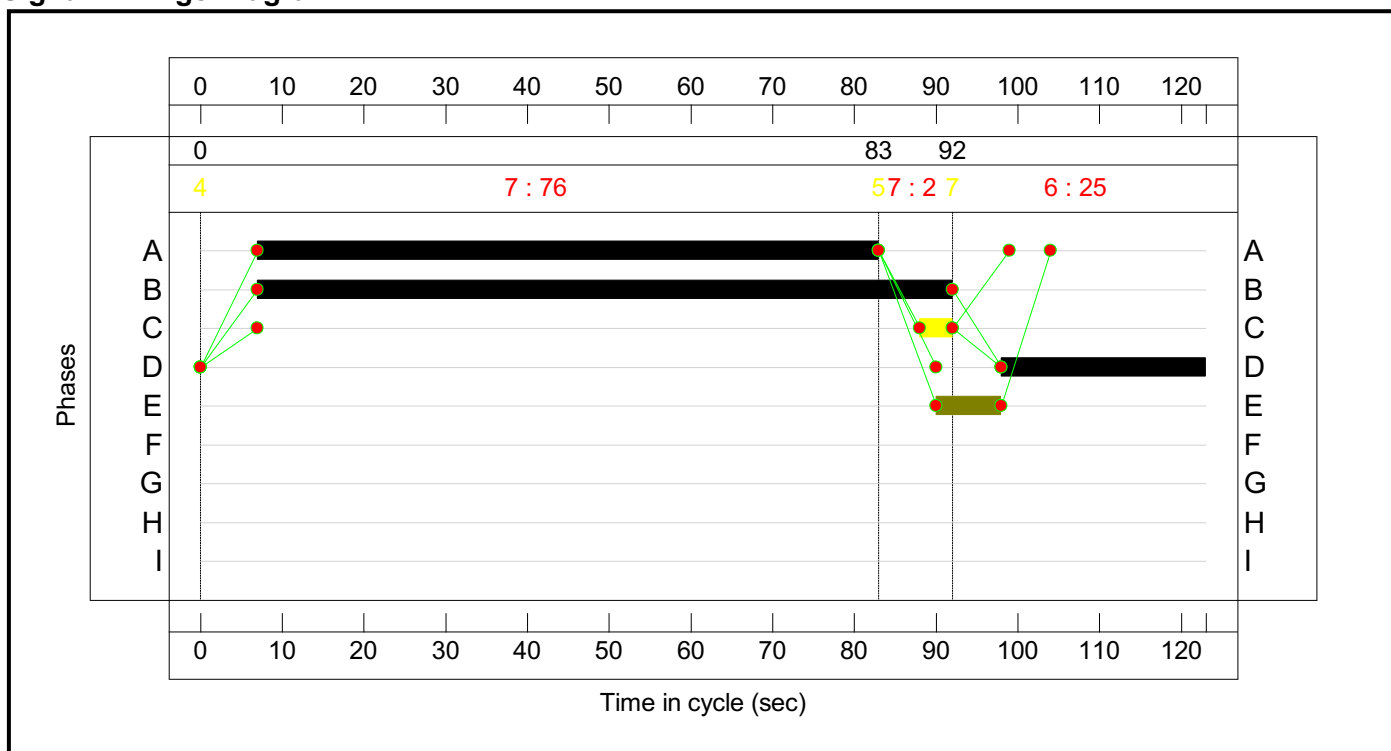

Network Layout Diagram

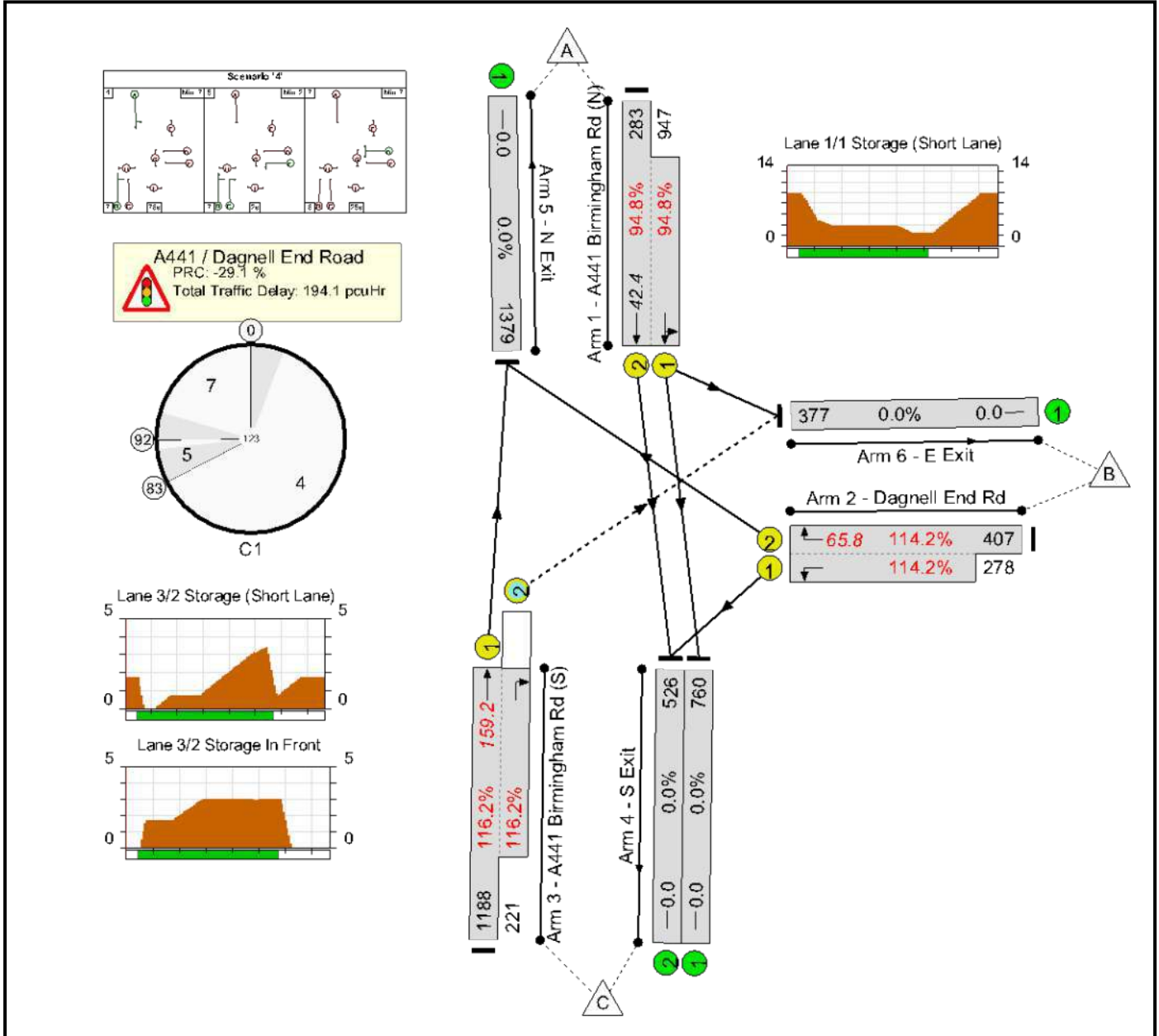

Full Input Data And Results

Network Results

Item	Lane Description	Lane Type	Controller Stream	Position In Filtered Route	Full Phase	Arrow Phase	Num Greens	Total Green (s)	Arrow Green (s)	Demand Flow (pcu)	Sat Flow (pcu/Hr)	Capacity (pcu)	Deg Sat (%)
Network: A441 / Dagnell End Road	-	-	N/A	-	-		-	-	-	-	-	-	116.2%
A441 / Dagnell End Road	-	-	N/A	-	-		-	-	-	-	-	-	116.2%
1/2+1/1	A441 Birmingham Rd (N) Ahead Left	U	N/A	N/A	A		1	76	-	1230	2105:1902	299+999	94.8 : 94.8%
2/2+2/1	Dagnell End Rd Left Right	U	N/A	N/A	D	E	1	25:33	8	685	1819:1742	356+243	114.2 : 114.2%
3/1+3/2	A441 Birmingham Rd (S) Ahead Right	U+O	N/A	N/A	B	C	1	85	4	1409	1641:1800	1023+190	116.2 : 116.2%
4/1	S Exit	U	N/A	N/A	-		-	-	-	760	Inf	Inf	0.0%
4/2	S Exit	U	N/A	N/A	-		-	-	-	561	Inf	Inf	0.0%
5/1	N Exit	U	N/A	N/A	-		-	-	-	1595	Inf	Inf	0.0%
6/1	E Exit	U	N/A	N/A	-		-	-	-	408	Inf	Inf	0.0%

Full Input Data And Results

Item	Arriving (pcu)	Leaving (pcu)	Turners In Gaps (pcu)	Turners When Unopposed (pcu)	Turners In Intergreen (pcu)	Uniform Delay (pcuHr)	Rand + Oversat Delay (pcuHr)	Storage Area Uniform Delay (pcuHr)	Total Delay (pcuHr)	Av. Delay Per PCU (s/pcu)	Max. Back of Uniform Queue (pcu)	Rand + Oversat Queue (pcu)	Mean Max Queue (pcu)
Network: A441 / Dagnell End Road	-	-	9	102	79	37.3	155.2	1.7	194.1	-	-	-	-
A441 / Dagnell End Road	-	-	9	102	79	37.3	155.2	1.7	194.1	-	-	-	-
1/2+1/1	1230	1230	-	-	-	6.4	7.5	-	13.9 (3.1+10.8)	40.6 (38.8:41.2)	34.9	7.5	42.4
2/2+2/1	685	600	-	-	-	13.0	46.2	-	59.3 (35.6+23.7)	311.5 (314.5:307.0)	19.6	46.2	65.8
3/1+3/2	1409	1213	9	102	79	17.8	101.5	1.7	121.0 (100.2+20.7)	309.1 (303.7:337.8)	57.7	101.5	159.2
4/1	760	760	-	-	-	0.0	0.0	-	0.0	0.0	0.0	0.0	0.0
4/2	526	526	-	-	-	0.0	0.0	-	0.0	0.0	0.0	0.0	0.0
5/1	1379	1379	-	-	-	0.0	0.0	-	0.0	0.0	0.0	0.0	0.0
6/1	377	377	-	-	-	0.0	0.0	-	0.0	0.0	0.0	0.0	0.0
C1 PRC for Signalled Lanes (%): -29.1 Total Delay for Signalled Lanes (pcuHr): 194.11 Cycle Time (s): 123 PRC Over All Lanes (%): -29.1 Total Delay Over All Lanes (pcuHr): 194.11													

Full Input Data And Results

Scenario 5: '5' (FG1: '2030 AM Effective Base', Plan 2: 'Network Control Plan 2 (no Peds, no left filter)')

Stage Sequence Diagram

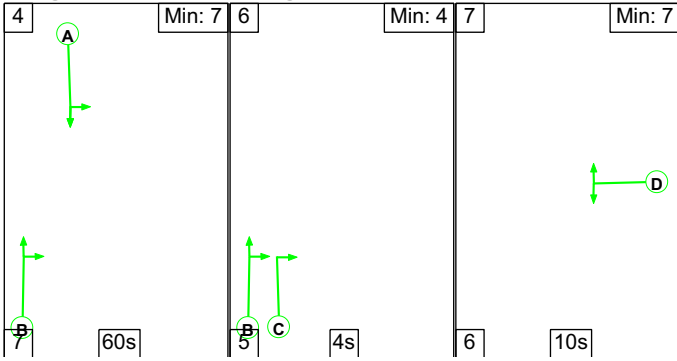

Stage Timings

Stage	4	6	7
Duration	60	4	10
Change Point	0	67	76

Signal Timings Diagram

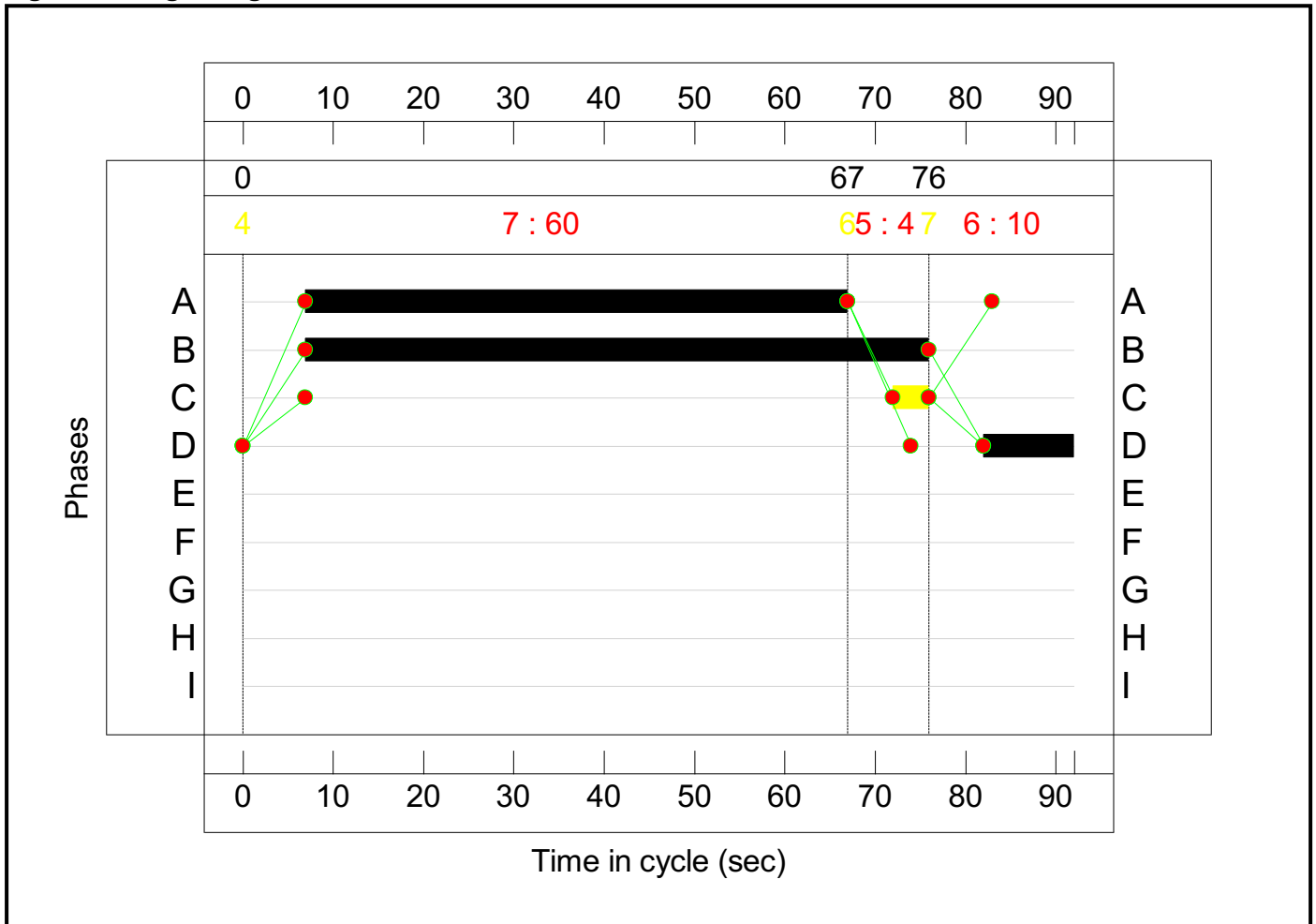

Network Layout Diagram

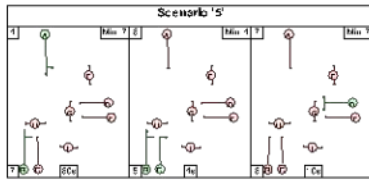

A441 / Dagnell End Road
 PRC: -12.0 %
 Total Traffic Delay: 45.0 pcu·hr

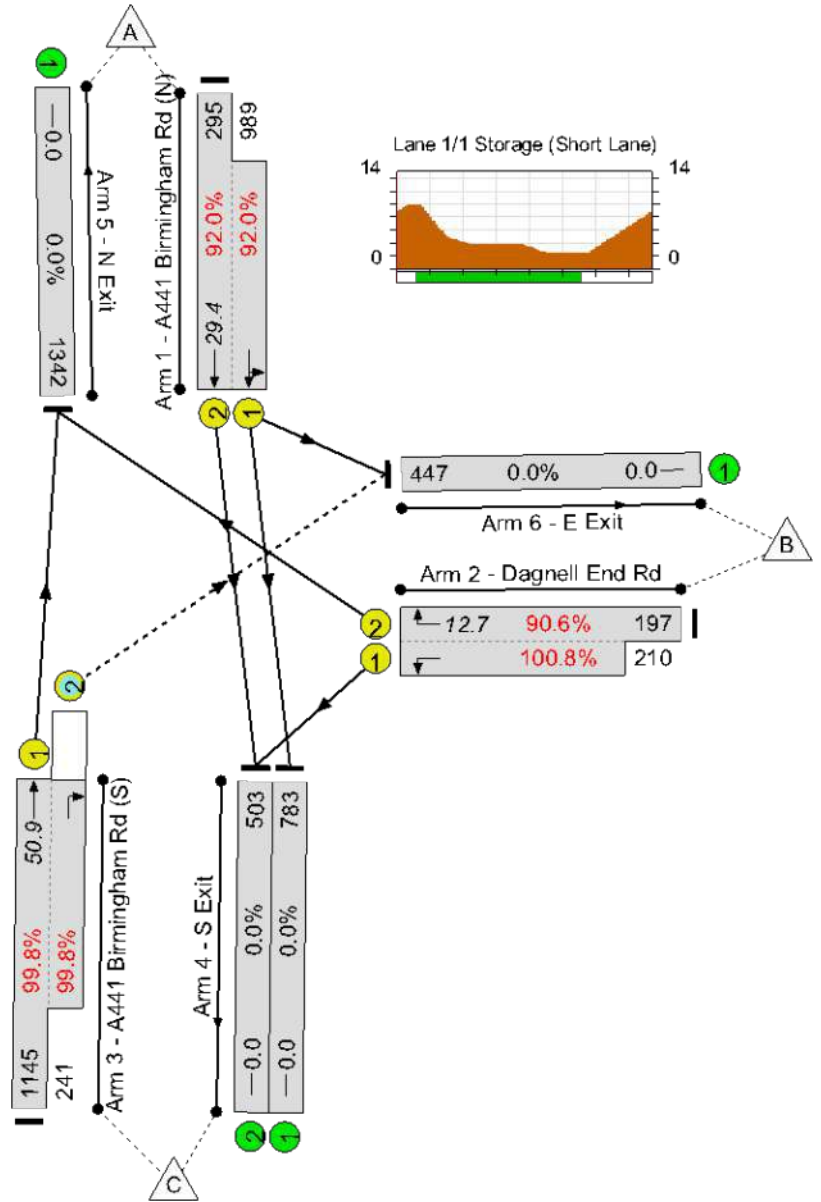
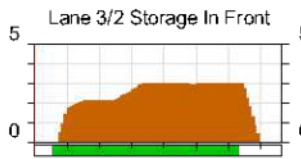
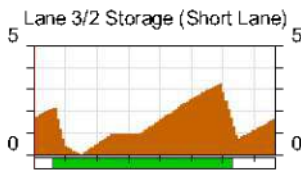
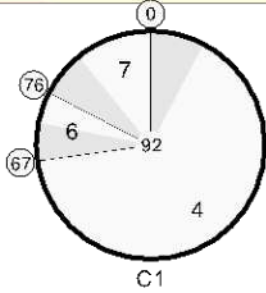

Full Input Data And Results

Network Results

Item	Lane Description	Lane Type	Controller Stream	Position In Filtered Route	Full Phase	Arrow Phase	Num Greens	Total Green (s)	Arrow Green (s)	Demand Flow (pcu)	Sat Flow (pcu/Hr)	Capacity (pcu)	Deg Sat (%)
Network: A441 / Dagnell End Road	-	-	N/A	-	-		-	-	-	-	-	-	100.8%
A441 / Dagnell End Road	-	-	N/A	-	-		-	-	-	-	-	-	100.8%
1/2+1/1	A441 Birmingham Rd (N) Ahead Left	U	N/A	N/A	A		1	60	-	1284	2105:1899	320+1074	92.0 : 92.0%
2/2+2/1	Dagnell End Rd Left Right	U	N/A	N/A	D	E	1	10	0	407	1819:1742	217+208	90.6 : 100.8%
3/1+3/2	A441 Birmingham Rd (S) Ahead Right	U+O	N/A	N/A	B	C	1	69	4	1386	1726:1679	1147+241	99.8 : 99.8%
4/1	S Exit	U	N/A	N/A	-		-	-	-	783	Inf	Inf	0.0%
4/2	S Exit	U	N/A	N/A	-		-	-	-	505	Inf	Inf	0.0%
5/1	N Exit	U	N/A	N/A	-		-	-	-	1342	Inf	Inf	0.0%
6/1	E Exit	U	N/A	N/A	-		-	-	-	447	Inf	Inf	0.0%

Full Input Data And Results

Item	Arriving (pcu)	Leaving (pcu)	Turners In Gaps (pcu)	Turners When Unopposed (pcu)	Turners In Intergreen (pcu)	Uniform Delay (pcuHr)	Rand + Oversat Delay (pcuHr)	Storage Area Uniform Delay (pcuHr)	Total Delay (pcuHr)	Av. Delay Per PCU (s/pcu)	Max. Back of Uniform Queue (pcu)	Rand + Oversat Queue (pcu)	Mean Max Queue (pcu)
Network: A441 / Dagnell End Road	-	-	6	128	107	12.6	30.6	1.8	45.0	-	-	-	-
A441 / Dagnell End Road	-	-	6	128	107	12.6	30.6	1.8	45.0	-	-	-	-
1/2+1/1	1284	1284	-	-	-	4.0	5.3	-	9.3 (2.0+7.3)	26.0 (23.9:26.6)	24.1	5.3	29.4
2/2+2/1	407	405	-	-	-	4.6	7.3	-	11.9 (5.3+6.6)	105.1 (96.9:112.9)	5.4	7.3	12.7
3/1+3/2	1386	1386	6	128	107	4.0	18.0	1.8	23.8 (17.9+5.9)	61.9 (56.2:88.8)	32.9	18.0	50.9
4/1	783	783	-	-	-	0.0	0.0	-	0.0	0.0	0.0	0.0	0.0
4/2	503	503	-	-	-	0.0	0.0	-	0.0	0.0	0.0	0.0	0.0
5/1	1342	1342	-	-	-	0.0	0.0	-	0.0	0.0	0.0	0.0	0.0
6/1	447	447	-	-	-	0.0	0.0	-	0.0	0.0	0.0	0.0	0.0
C1 PRC for Signalled Lanes (%): -12.0 Total Delay for Signalled Lanes (pcuHr): 44.98 Cycle Time (s): 92 PRC Over All Lanes (%): -12.0 Total Delay Over All Lanes(pcuHr): 44.98													

Full Input Data And Results

Scenario 6: '6' (FG2: '2030 PM Effective Base', Plan 2: 'Network Control Plan 2 (no Peds, no left filter)')

Stage Sequence Diagram

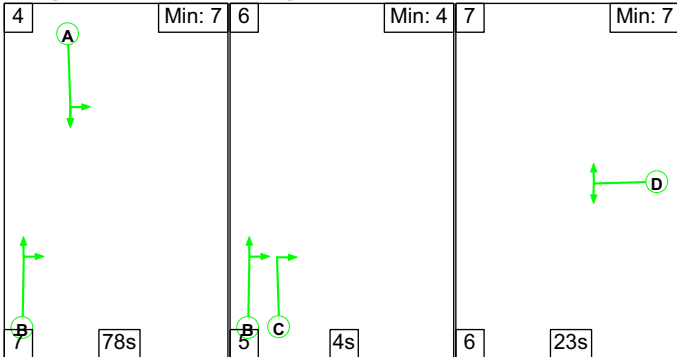

Stage Timings

Stage	4	6	7
Duration	78	4	23
Change Point	0	85	94

Signal Timings Diagram

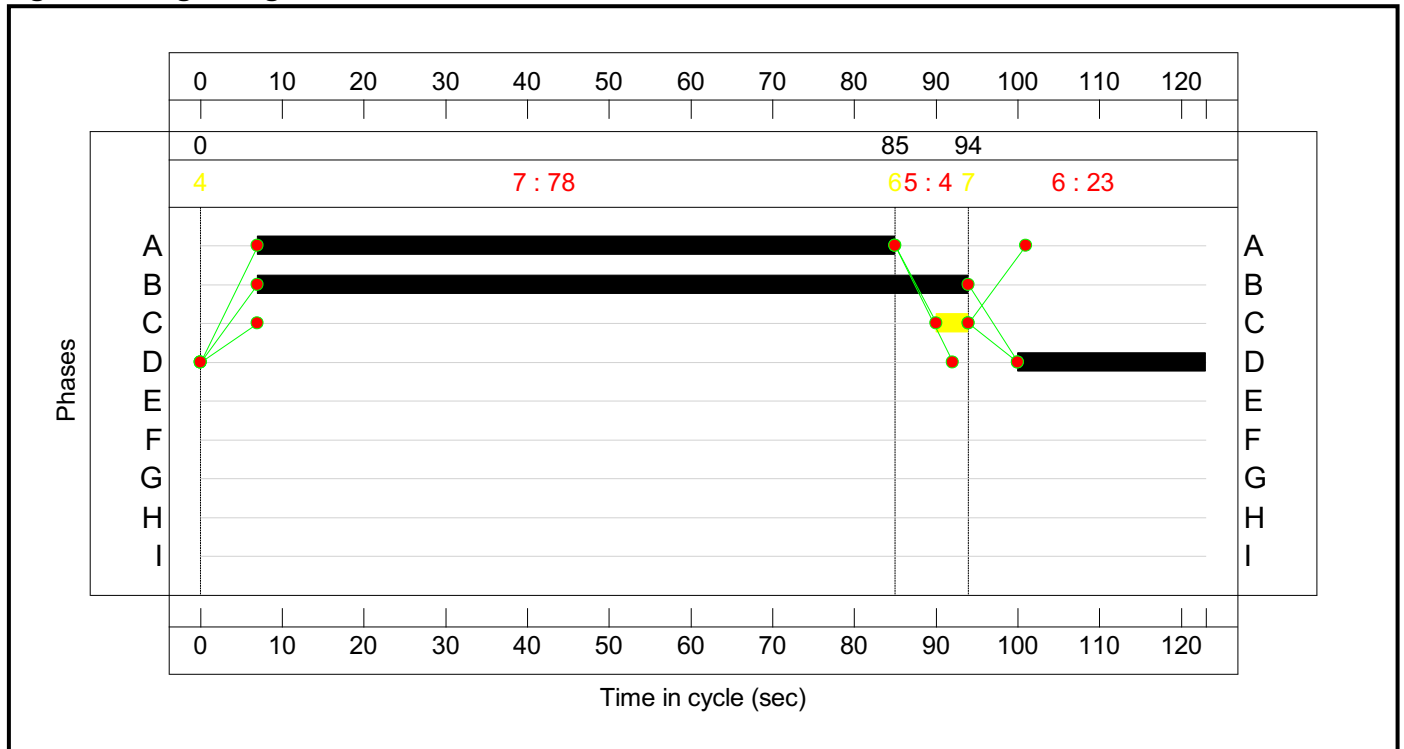

Network Layout Diagram

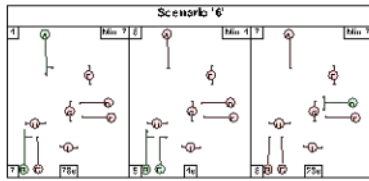

A441 / Dagnell End Road
 PRC: -24.1 %
 Total Traffic Delay: 146.1 pcuHr

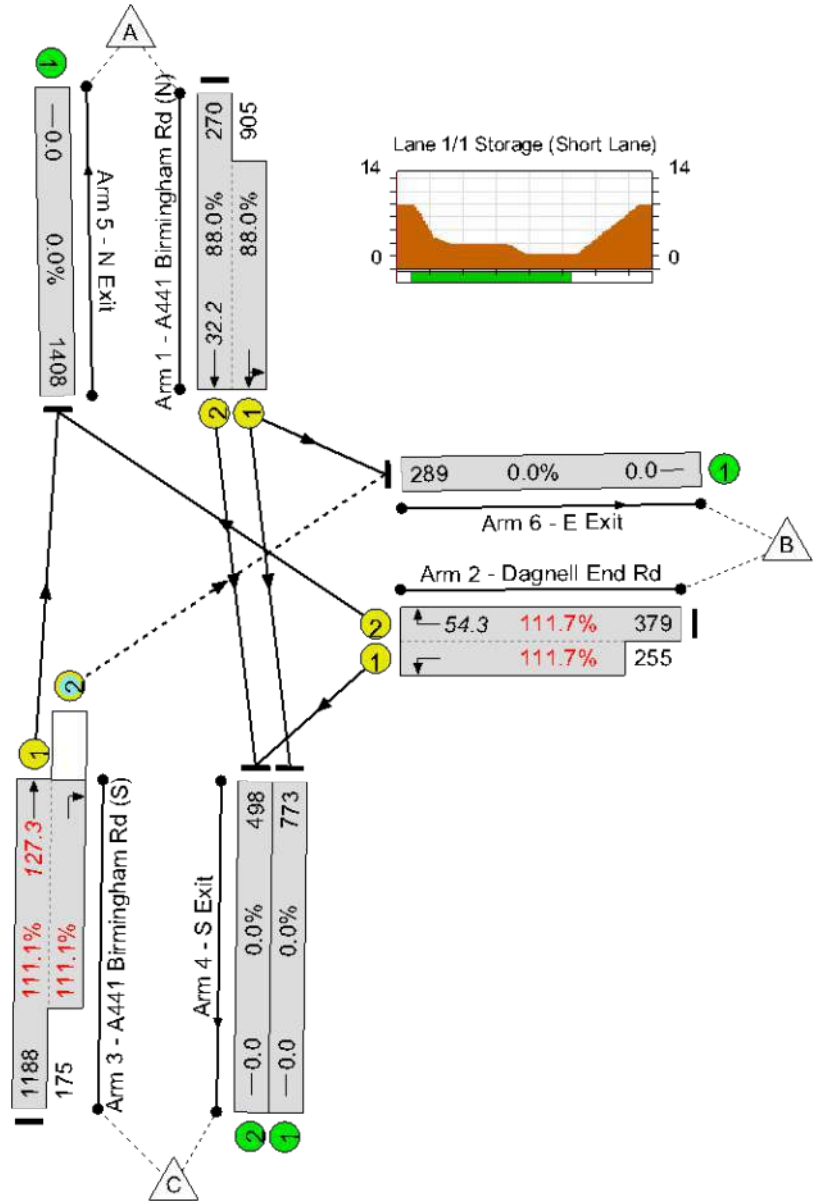
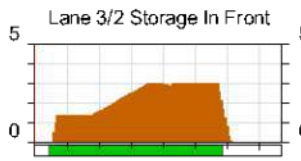
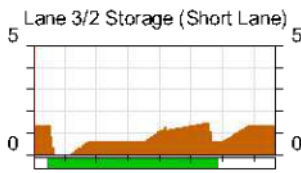
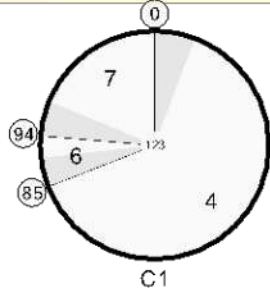

Full Input Data And Results

Network Results

Item	Lane Description	Lane Type	Controller Stream	Position In Filtered Route	Full Phase	Arrow Phase	Num Greens	Total Green (s)	Arrow Green (s)	Demand Flow (pcu)	Sat Flow (pcu/Hr)	Capacity (pcu)	Deg Sat (%)
Network: A441 / Dagnell End Road	-	-	N/A	-	-		-	-	-	-	-	-	111.7%
A441 / Dagnell End Road	-	-	N/A	-	-		-	-	-	-	-	-	111.7%
1/2+1/1	A441 Birmingham Rd (N) Ahead Left	U	N/A	N/A	A		1	78	-	1175	2105:1918	307+1028	88.0 : 88.0%
2/2+2/1	Dagnell End Rd Left Right	U	N/A	N/A	D	E	1	23	0	634	1819:1742	339+228	111.7 : 111.7%
3/1+3/2	A441 Birmingham Rd (S) Ahead Right	U+O	N/A	N/A	B	C	1	87	4	1363	1641:1800	1069+157	111.1 : 111.1%
4/1	S Exit	U	N/A	N/A	-		-	-	-	773	Inf	Inf	0.0%
4/2	S Exit	U	N/A	N/A	-		-	-	-	525	Inf	Inf	0.0%
5/1	N Exit	U	N/A	N/A	-		-	-	-	1567	Inf	Inf	0.0%
6/1	E Exit	U	N/A	N/A	-		-	-	-	307	Inf	Inf	0.0%

Full Input Data And Results

Item	Arriving (pcu)	Leaving (pcu)	Turners In Gaps (pcu)	Turners When Unopposed (pcu)	Turners In Intergreen (pcu)	Uniform Delay (pcuHr)	Rand + Oversat Delay (pcuHr)	Storage Area Uniform Delay (pcuHr)	Total Delay (pcuHr)	Av. Delay Per PCU (s/pcu)	Max. Back of Uniform Queue (pcu)	Rand + Oversat Queue (pcu)	Mean Max Queue (pcu)
Network: A441 / Dagnell End Road	-	-	32	102	23	30.7	113.9	1.5	146.1	-	-	-	-
A441 / Dagnell End Road	-	-	32	102	23	30.7	113.9	1.5	146.1	-	-	-	-
1/2+1/1	1175	1175	-	-	-	5.1	3.5	-	8.7 (1.9+6.8)	26.5 (24.7:27.1)	28.7	3.5	32.2
2/2+2/1	634	568	-	-	-	11.9	37.4	-	49.3 (29.5+19.8)	279.9 (280.3:279.2)	16.9	37.4	54.3
3/1+3/2	1363	1226	32	102	23	13.7	73.0	1.5	88.1 (75.4+12.7)	232.7 (228.6:260.5)	54.3	73.0	127.3
4/1	773	773	-	-	-	0.0	0.0	-	0.0	0.0	0.0	0.0	0.0
4/2	498	498	-	-	-	0.0	0.0	-	0.0	0.0	0.0	0.0	0.0
5/1	1408	1408	-	-	-	0.0	0.0	-	0.0	0.0	0.0	0.0	0.0
6/1	289	289	-	-	-	0.0	0.0	-	0.0	0.0	0.0	0.0	0.0
C1 PRC for Signalled Lanes (%): -24.1 Total Delay for Signalled Lanes (pcuHr): 146.06 Cycle Time (s): 123 PRC Over All Lanes (%): -24.1 Total Delay Over All Lanes(pcuHr): 146.06													

Full Input Data And Results

Scenario 7: '7' (FG3: '2030 AM Effective Base + Dev', Plan 2: 'Network Control Plan 2 (no Peds, no left filter)')

Stage Sequence Diagram

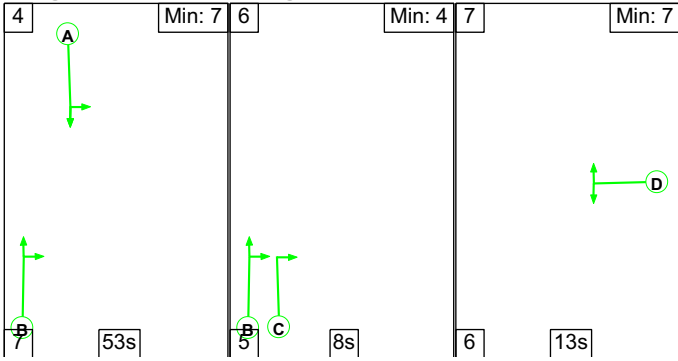

Stage Timings

Stage	4	6	7
Duration	53	8	13
Change Point	0	60	73

Signal Timings Diagram

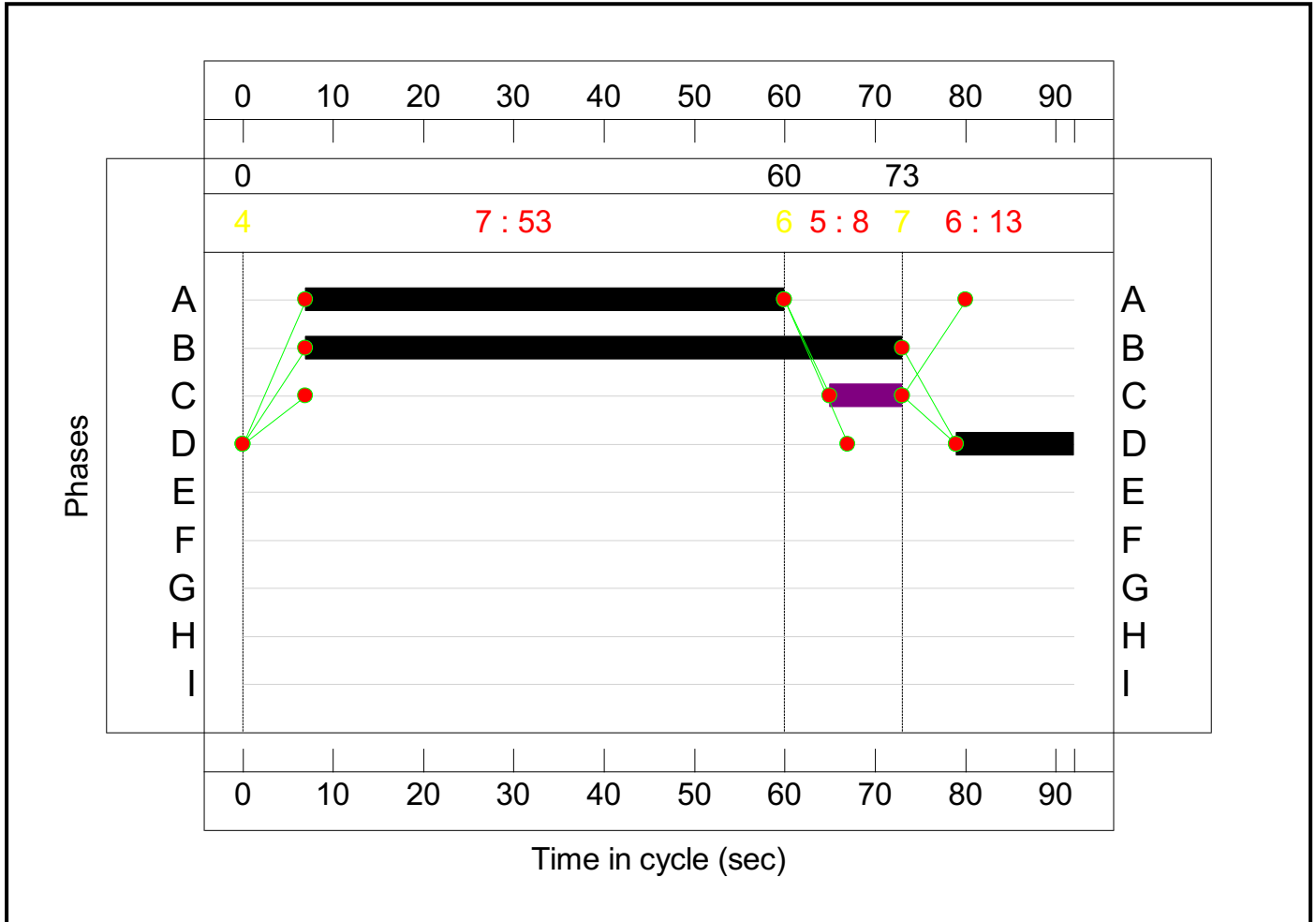

Network Layout Diagram

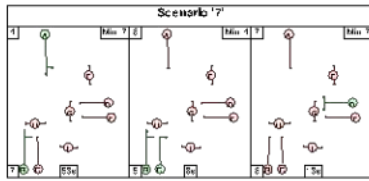

A441 / Dagnell End Road
 PRC: -16.5 %
 Total Traffic Delay: 107.9 pcuHr

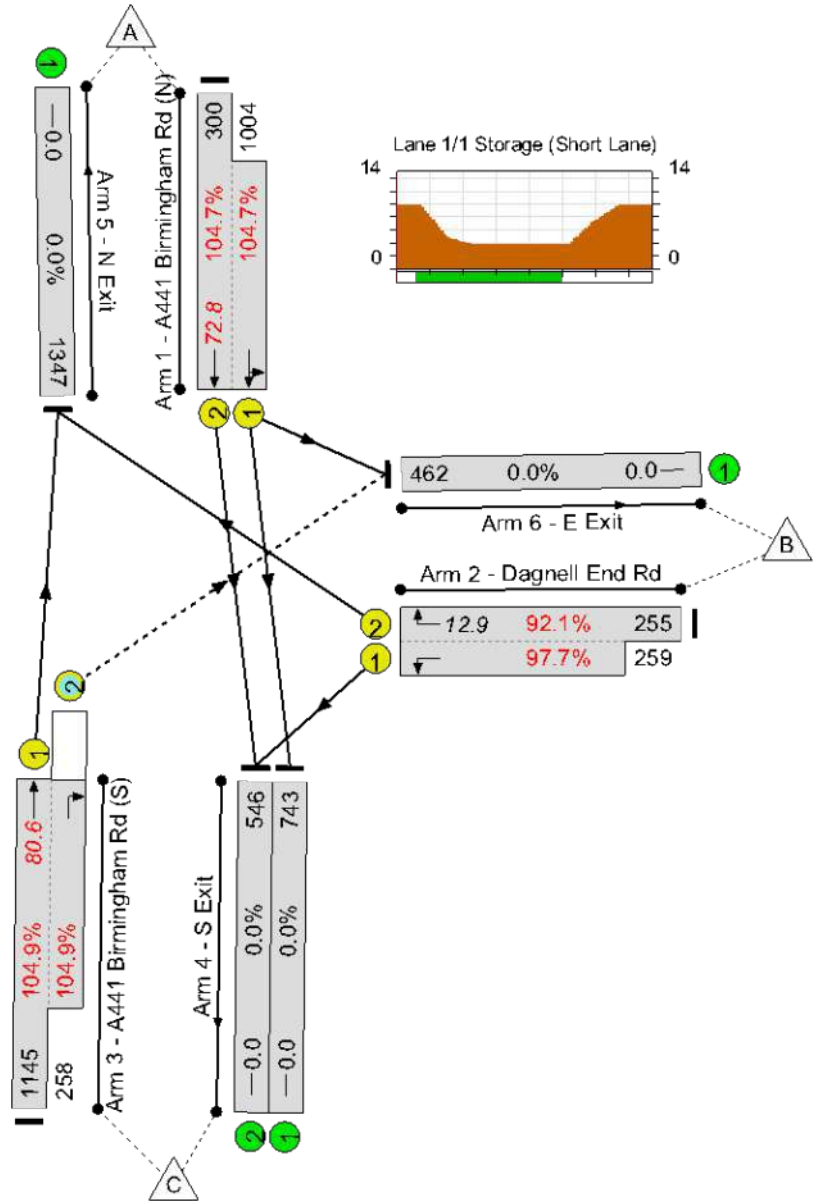
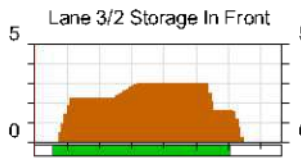
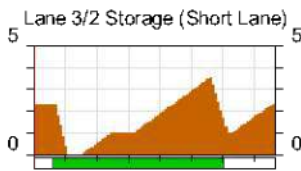
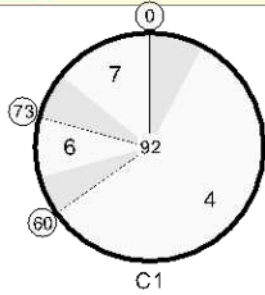

Full Input Data And Results

Network Results

Item	Lane Description	Lane Type	Controller Stream	Position In Filtered Route	Full Phase	Arrow Phase	Num Greens	Total Green (s)	Arrow Green (s)	Demand Flow (pcu)	Sat Flow (pcu/Hr)	Capacity (pcu)	Deg Sat (%)
Network: A441 / Dagnell End Road	-	-	N/A	-	-		-	-	-	-	-	-	104.9%
A441 / Dagnell End Road	-	-	N/A	-	-		-	-	-	-	-	-	104.9%
1/2+1/1	A441 Birmingham Rd (N) Ahead Left	U	N/A	N/A	A		1	53	-	1304	2105:1894	287+959	104.7 : 104.7%
2/2+2/1	Dagnell End Rd Left Right	U	N/A	N/A	D	E	1	13	0	514	1819:1742	277+265	92.1 : 97.7%
3/1+3/2	A441 Birmingham Rd (S) Ahead Right	U+O	N/A	N/A	B	C	1	66	8	1403	1726:1679	1092+246	104.9 : 104.9%
4/1	S Exit	U	N/A	N/A	-		-	-	-	778	Inf	Inf	0.0%
4/2	S Exit	U	N/A	N/A	-		-	-	-	559	Inf	Inf	0.0%
5/1	N Exit	U	N/A	N/A	-		-	-	-	1400	Inf	Inf	0.0%
6/1	E Exit	U	N/A	N/A	-		-	-	-	484	Inf	Inf	0.0%

Full Input Data And Results

Item	Arriving (pcu)	Leaving (pcu)	Turners In Gaps (pcu)	Turners When Unopposed (pcu)	Turners In Intergreen (pcu)	Uniform Delay (pcuHr)	Rand + Oversat Delay (pcuHr)	Storage Area Uniform Delay (pcuHr)	Total Delay (pcuHr)	Av. Delay Per PCU (s/pcu)	Max. Back of Uniform Queue (pcu)	Rand + Oversat Queue (pcu)	Mean Max Queue (pcu)
Network: A441 / Dagnell End Road	-	-	0	201	45	21.2	85.1	1.6	107.9	-	-	-	-
A441 / Dagnell End Road	-	-	0	201	45	21.2	85.1	1.6	107.9	-	-	-	-
1/2+1/1	1304	1246	-	-	-	8.5	37.7	-	46.2 (10.4+35.8)	127.6 (125.1:128.4)	35.1	37.7	72.8
2/2+2/1	514	514	-	-	-	5.5	6.3	-	11.9 (5.9+6.0)	83.0 (82.8:83.2)	6.5	6.3	12.9
3/1+3/2	1403	1338	0	201	45	7.2	41.0	1.6	49.8 (39.1+10.7)	127.7 (122.9:149.4)	39.5	41.0	80.6
4/1	743	743	-	-	-	0.0	0.0	-	0.0	0.0	0.0	0.0	0.0
4/2	546	546	-	-	-	0.0	0.0	-	0.0	0.0	0.0	0.0	0.0
5/1	1347	1347	-	-	-	0.0	0.0	-	0.0	0.0	0.0	0.0	0.0
6/1	462	462	-	-	-	0.0	0.0	-	0.0	0.0	0.0	0.0	0.0
C1 PRC for Signalled Lanes (%): -16.5 Total Delay for Signalled Lanes (pcuHr): 107.88 Cycle Time (s): 92 PRC Over All Lanes (%): -16.5 Total Delay Over All Lanes(pcuHr): 107.88													

Full Input Data And Results

Scenario 8: '8' (FG4: '2030 PM Effective Base + Dev', Plan 2: 'Network Control Plan 2 (no Peds, no left filter)')

Stage Sequence Diagram

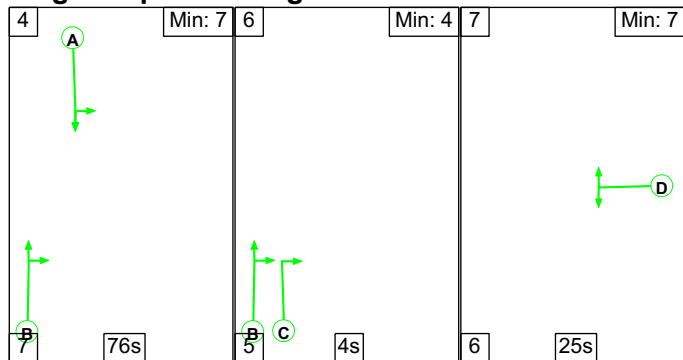

Stage Timings

Stage	4	6	7
Duration	76	4	25
Change Point	0	83	92

Signal Timings Diagram

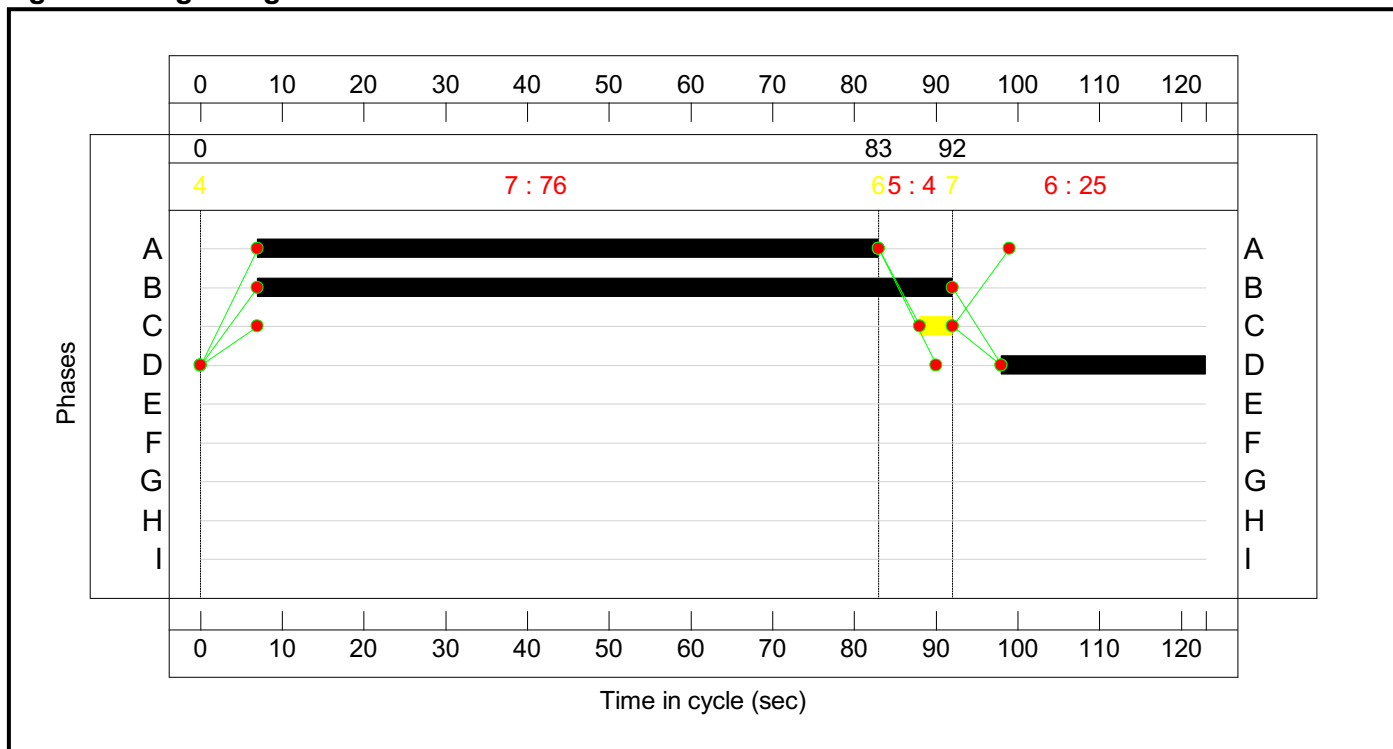

Network Layout Diagram

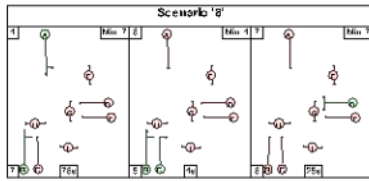

A441 / Dagnell End Road
 PRC: -29.1 %
 Total Traffic Delay: 194.6 pcuHr

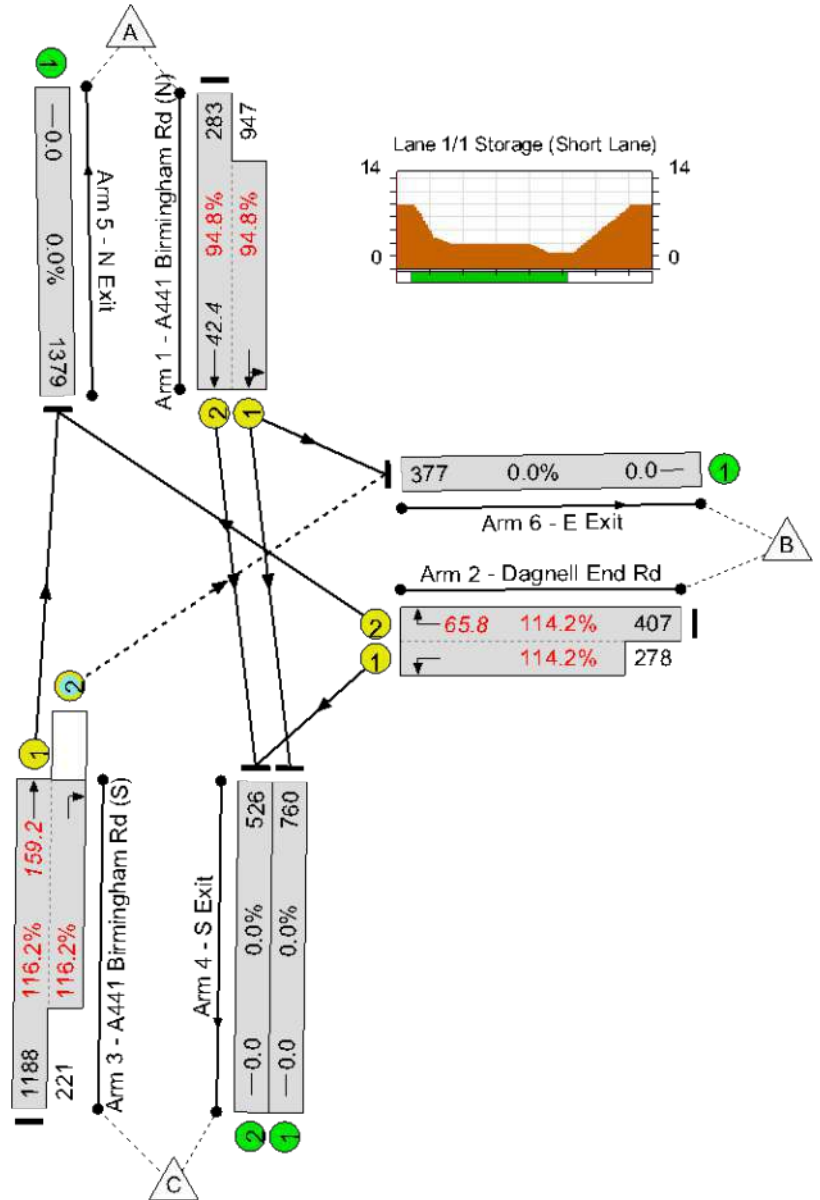
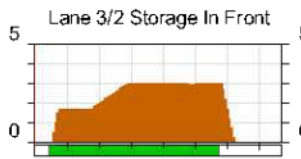
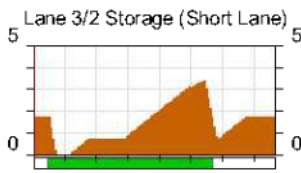
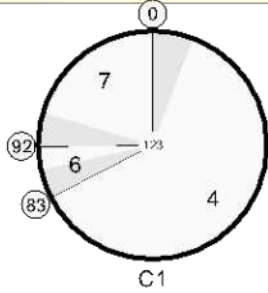

Full Input Data And Results

Network Results

Item	Lane Description	Lane Type	Controller Stream	Position In Filtered Route	Full Phase	Arrow Phase	Num Greens	Total Green (s)	Arrow Green (s)	Demand Flow (pcu)	Sat Flow (pcu/Hr)	Capacity (pcu)	Deg Sat (%)
Network: A441 / Dagnell End Road	-	-	N/A	-	-		-	-	-	-	-	-	116.2%
A441 / Dagnell End Road	-	-	N/A	-	-		-	-	-	-	-	-	116.2%
1/2+1/1	A441 Birmingham Rd (N) Ahead Left	U	N/A	N/A	A		1	76	-	1230	2105:1902	299+999	94.8 : 94.8%
2/2+2/1	Dagnell End Rd Left Right	U	N/A	N/A	D	E	1	25	0	685	1819:1742	356+243	114.2 : 114.2%
3/1+3/2	A441 Birmingham Rd (S) Ahead Right	U+O	N/A	N/A	B	C	1	85	4	1409	1641:1800	1023+190	116.2 : 116.2%
4/1	S Exit	U	N/A	N/A	-		-	-	-	760	Inf	Inf	0.0%
4/2	S Exit	U	N/A	N/A	-		-	-	-	561	Inf	Inf	0.0%
5/1	N Exit	U	N/A	N/A	-		-	-	-	1595	Inf	Inf	0.0%
6/1	E Exit	U	N/A	N/A	-		-	-	-	408	Inf	Inf	0.0%

Full Input Data And Results

Item	Arriving (pcu)	Leaving (pcu)	Turners In Gaps (pcu)	Turners When Unopposed (pcu)	Turners In Intergreen (pcu)	Uniform Delay (pcuHr)	Rand + Oversat Delay (pcuHr)	Storage Area Uniform Delay (pcuHr)	Total Delay (pcuHr)	Av. Delay Per PCU (s/pcu)	Max. Back of Uniform Queue (pcu)	Rand + Oversat Queue (pcu)	Mean Max Queue (pcu)
Network: A441 / Dagnell End Road	-	-	9	102	79	37.8	155.2	1.7	194.6	-	-	-	-
A441 / Dagnell End Road	-	-	9	102	79	37.8	155.2	1.7	194.6	-	-	-	-
1/2+1/1	1230	1230	-	-	-	6.4	7.5	-	13.9 (3.1+10.8)	40.6 (38.8:41.2)	34.9	7.5	42.4
2/2+2/1	685	600	-	-	-	13.5	46.2	-	59.8 (35.6+24.2)	314.1 (314.5:313.5)	19.6	46.2	65.8
3/1+3/2	1409	1213	9	102	79	17.8	101.5	1.7	121.0 (100.2+20.7)	309.1 (303.7:337.8)	57.7	101.5	159.2
4/1	760	760	-	-	-	0.0	0.0	-	0.0	0.0	0.0	0.0	0.0
4/2	526	526	-	-	-	0.0	0.0	-	0.0	0.0	0.0	0.0	0.0
5/1	1379	1379	-	-	-	0.0	0.0	-	0.0	0.0	0.0	0.0	0.0
6/1	377	377	-	-	-	0.0	0.0	-	0.0	0.0	0.0	0.0	0.0
C1 PRC for Signalled Lanes (%): -29.1 Total Delay for Signalled Lanes (pcuHr): 194.61 Cycle Time (s): 123 PRC Over All Lanes (%): -29.1 Total Delay Over All Lanes(pcuHr): 194.61													

Full Input Data And Results

Scenario 9: '9' (FG1: '2030 AM Effective Base', Plan 3: 'Network Control Plan 3 (Peds)')

Stage Sequence Diagram

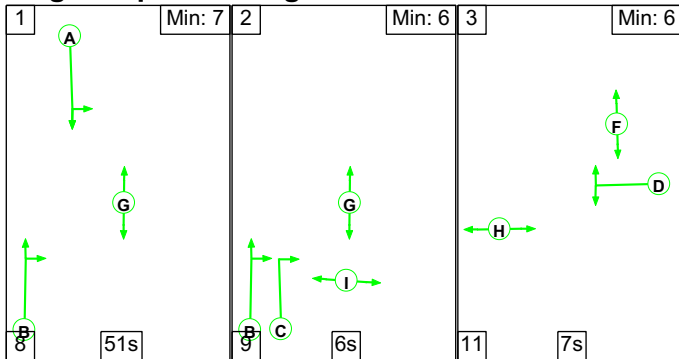

Stage Timings

Stage	1	2	3
Duration	51	6	7
Change Point	0	59	74

Signal Timings Diagram

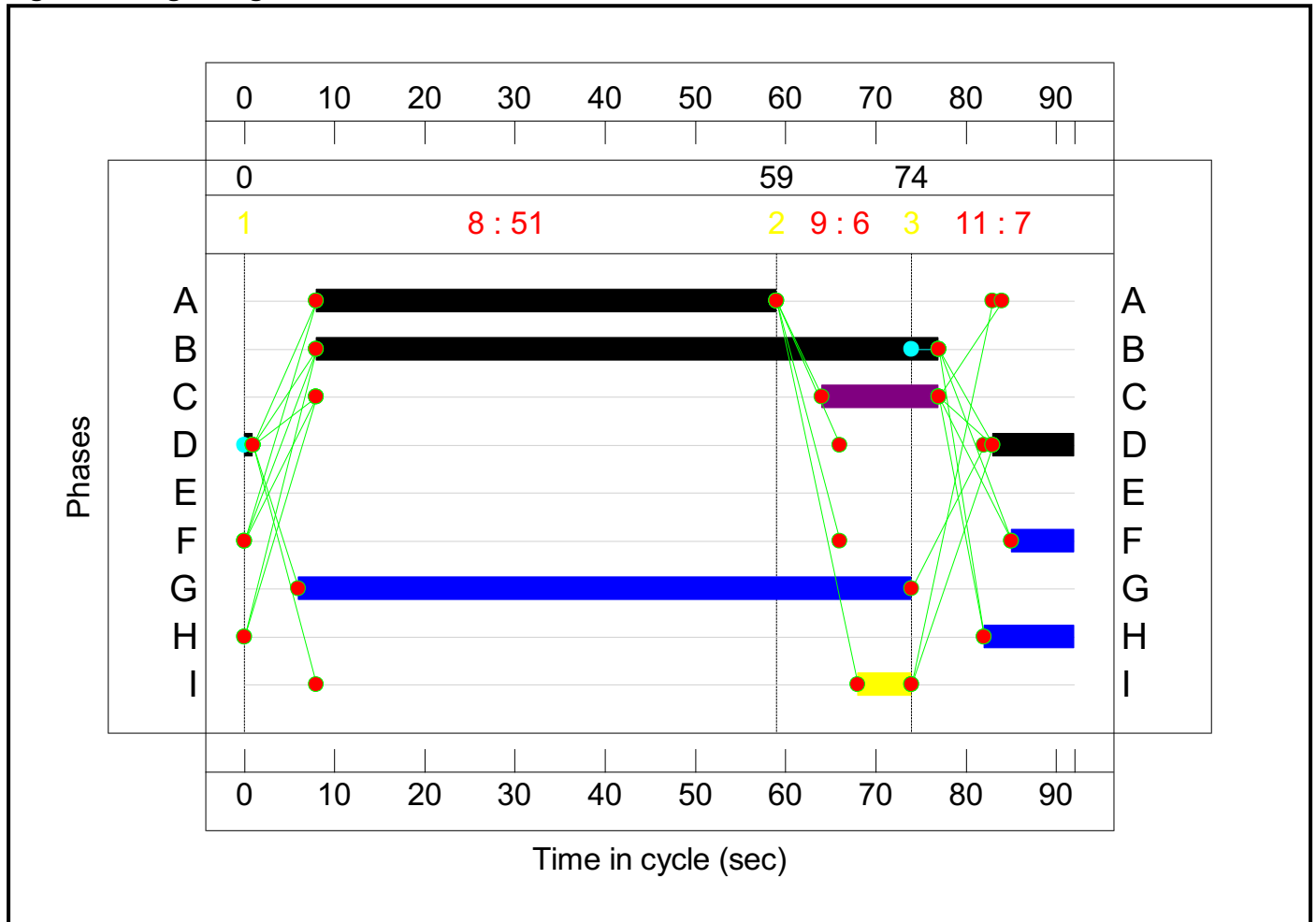

Network Layout Diagram

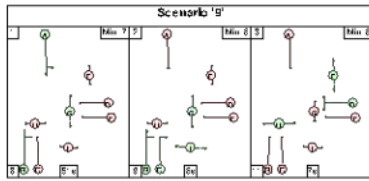

A441 / Dagnell End Road
 PRC: -18.4 %
 Total Traffic Delay: 91.3 pcu·hr

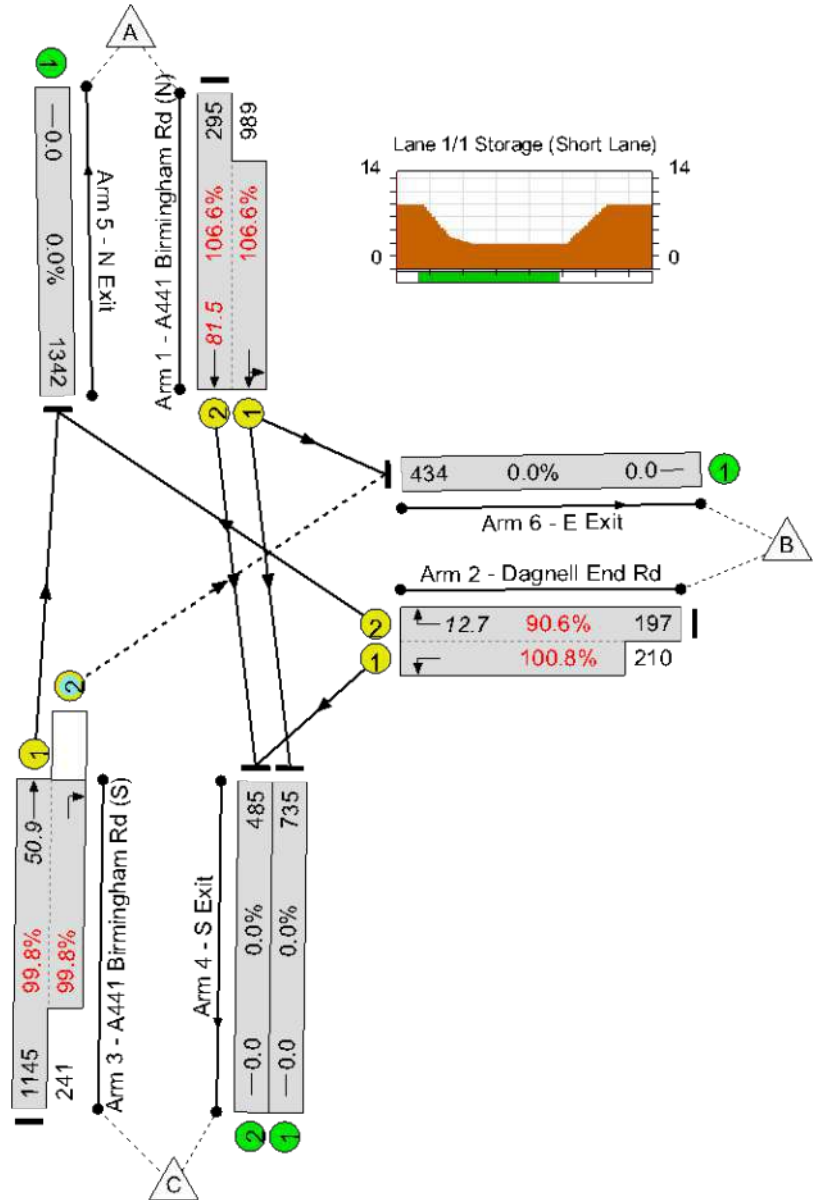
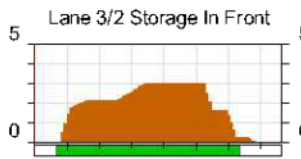
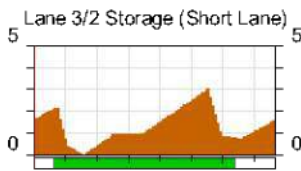
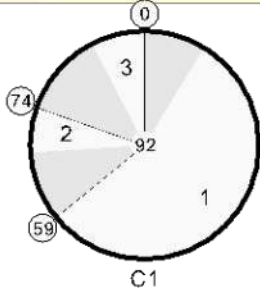

Full Input Data And Results

Network Results

Item	Lane Description	Lane Type	Controller Stream	Position In Filtered Route	Full Phase	Arrow Phase	Num Greens	Total Green (s)	Arrow Green (s)	Demand Flow (pcu)	Sat Flow (pcu/Hr)	Capacity (pcu)	Deg Sat (%)
Network: A441 / Dagnell End Road	-	-	N/A	-	-		-	-	-	-	-	-	106.6%
A441 / Dagnell End Road	-	-	N/A	-	-		-	-	-	-	-	-	106.6%
1/2+1/1	A441 Birmingham Rd (N) Ahead Left	U	N/A	N/A	A		1	51	-	1284	2105:1899	277+928	106.6 : 106.6%
2/2+2/1	Dagnell End Rd Left Right	U	N/A	N/A	D	E	1	10	0	407	1819:1742	217+208	90.6 : 100.8%
3/1+3/2	A441 Birmingham Rd (S) Ahead Right	U+O	N/A	N/A	B	C	1	69	13	1386	1726:1679	1147+241	99.8 : 99.8%
4/1	S Exit	U	N/A	N/A	-		-	-	-	783	Inf	Inf	0.0%
4/2	S Exit	U	N/A	N/A	-		-	-	-	505	Inf	Inf	0.0%
5/1	N Exit	U	N/A	N/A	-		-	-	-	1342	Inf	Inf	0.0%
6/1	E Exit	U	N/A	N/A	-		-	-	-	447	Inf	Inf	0.0%

Full Input Data And Results

Item	Arriving (pcu)	Leaving (pcu)	Turners In Gaps (pcu)	Turners When Unopposed (pcu)	Turners In Intergreen (pcu)	Uniform Delay (pcuHr)	Rand + Oversat Delay (pcuHr)	Storage Area Uniform Delay (pcuHr)	Total Delay (pcuHr)	Av. Delay Per PCU (s/pcu)	Max. Back of Uniform Queue (pcu)	Rand + Oversat Queue (pcu)	Mean Max Queue (pcu)
Network: A441 / Dagnell End Road	-	-	0	232	9	18.0	71.8	1.5	91.3	-	-	-	-
A441 / Dagnell End Road	-	-	0	232	9	18.0	71.8	1.5	91.3	-	-	-	-
1/2+1/1	1284	1205	-	-	-	9.6	46.5	-	56.1 (12.7+43.4)	157.3 (154.8:158.1)	35.1	46.5	81.5
2/2+2/1	407	405	-	-	-	4.6	7.3	-	11.9 (5.3+6.6)	105.1 (96.9:112.9)	5.4	7.3	12.7
3/1+3/2	1386	1386	0	232	9	3.8	18.0	1.5	23.3 (17.9+5.4)	60.5 (56.2:80.6)	32.9	18.0	50.9
4/1	735	735	-	-	-	0.0	0.0	-	0.0	0.0	0.0	0.0	0.0
4/2	485	485	-	-	-	0.0	0.0	-	0.0	0.0	0.0	0.0	0.0
5/1	1342	1342	-	-	-	0.0	0.0	-	0.0	0.0	0.0	0.0	0.0
6/1	434	434	-	-	-	0.0	0.0	-	0.0	0.0	0.0	0.0	0.0
C1 PRC for Signalled Lanes (%): -18.4 Total Delay for Signalled Lanes (pcuHr): 91.28 Cycle Time (s): 92 PRC Over All Lanes (%): -18.4 Total Delay Over All Lanes(pcuHr): 91.28													

Full Input Data And Results

Scenario 10: '10' (FG2: '2030 PM Effective Base', Plan 3: 'Network Control Plan 3 (Peds)')

Stage Sequence Diagram

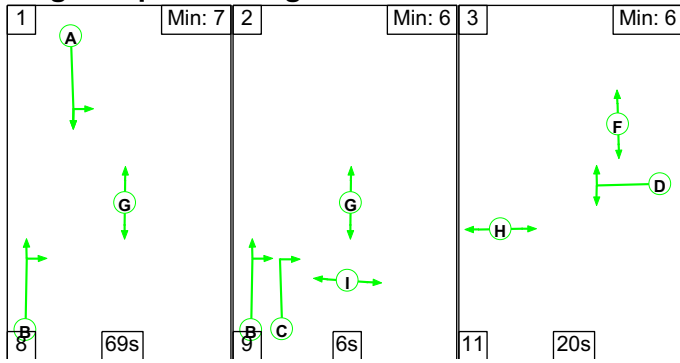

Stage Timings

Stage	1	2	3
Duration	69	6	20
Change Point	0	77	92

Signal Timings Diagram

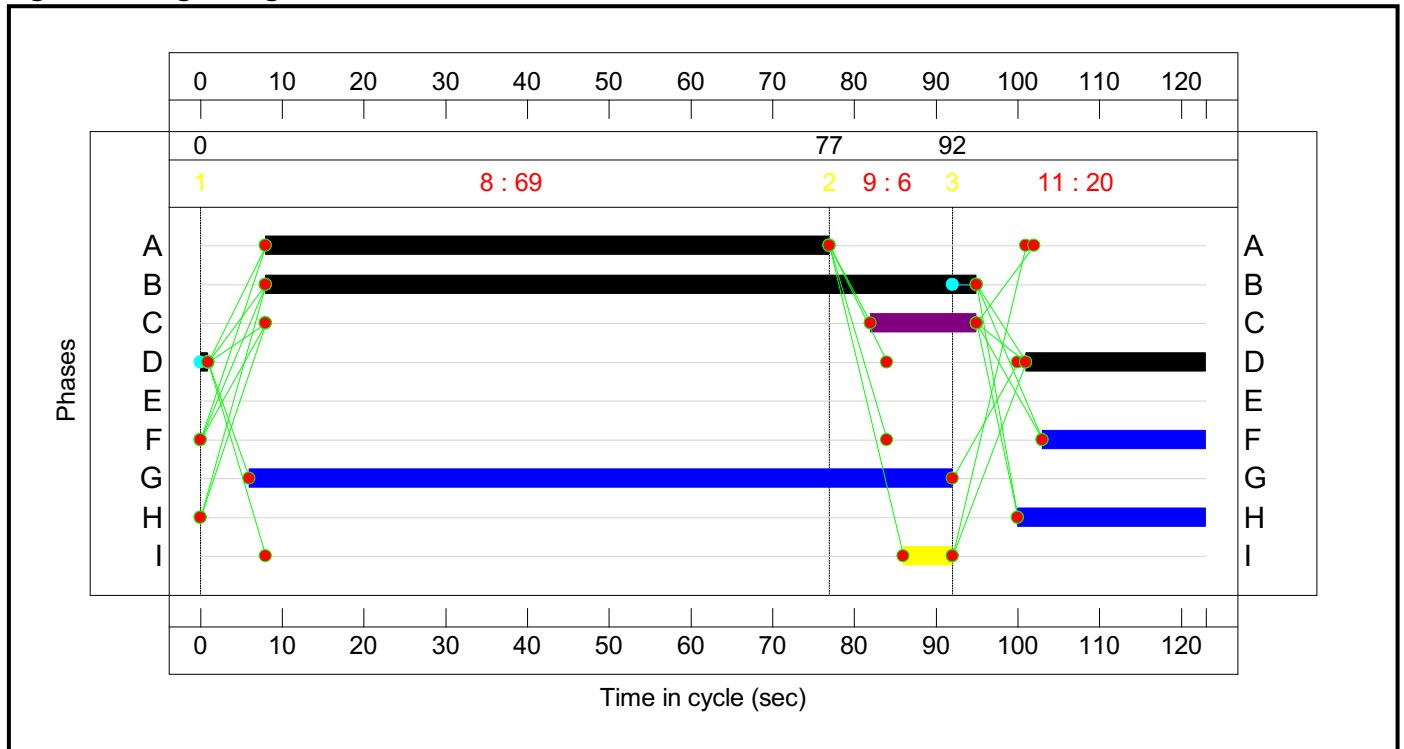

Network Layout Diagram

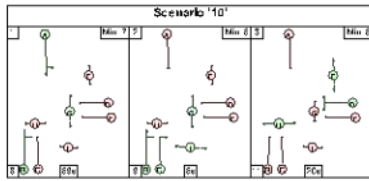

A441 / Dagnell End Road
 PRC: -24.1 %
 Total Traffic Delay: 158.5 pcuHr

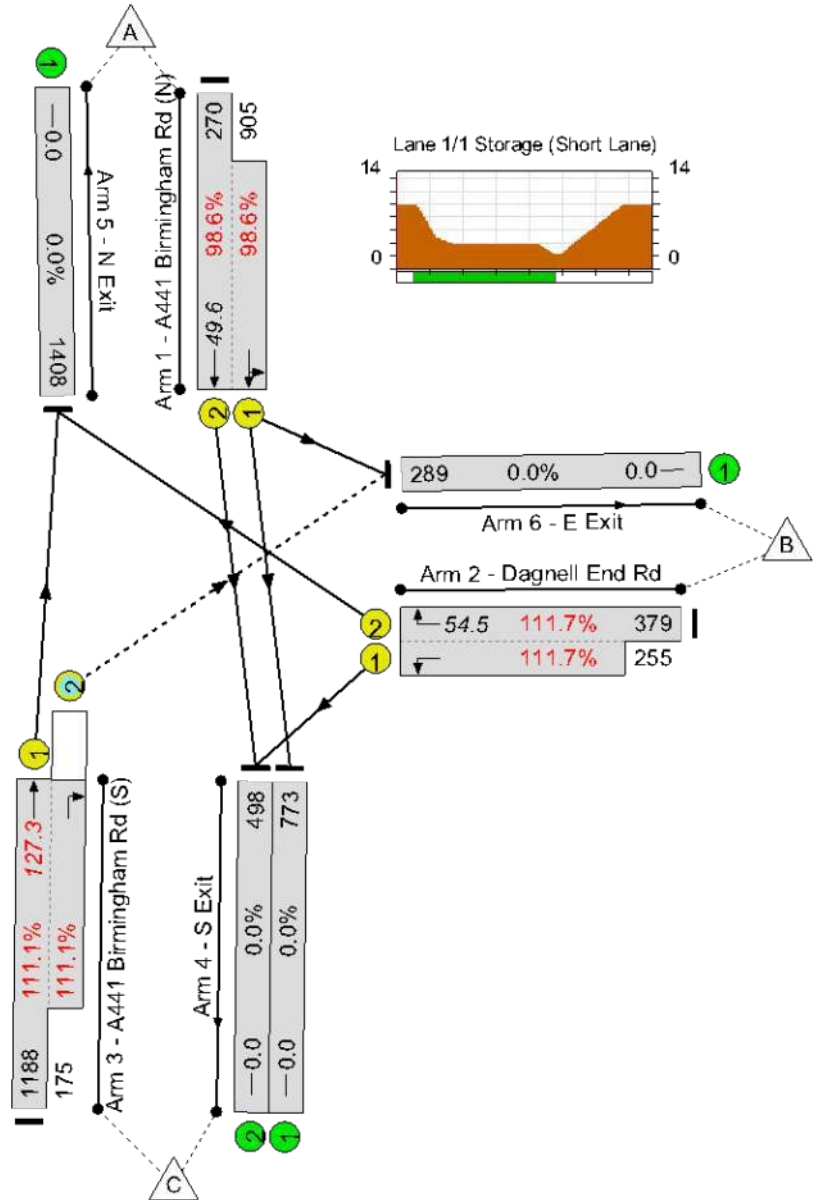
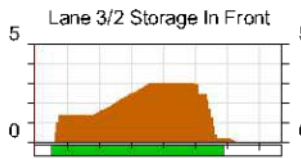
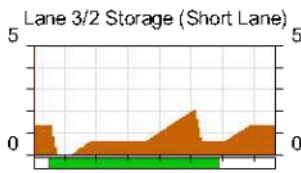
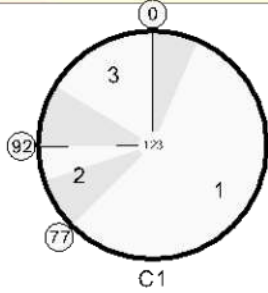

Full Input Data And Results

Network Results

Item	Lane Description	Lane Type	Controller Stream	Position In Filtered Route	Full Phase	Arrow Phase	Num Greens	Total Green (s)	Arrow Green (s)	Demand Flow (pcu)	Sat Flow (pcu/Hr)	Capacity (pcu)	Deg Sat (%)
Network: A441 / Dagnell End Road	-	-	N/A	-	-		-	-	-	-	-	-	111.7%
A441 / Dagnell End Road	-	-	N/A	-	-		-	-	-	-	-	-	111.7%
1/2+1/1	A441 Birmingham Rd (N) Ahead Left	U	N/A	N/A	A		1	69	-	1175	2105:1918	274+918	98.6 : 98.6%
2/2+2/1	Dagnell End Rd Left Right	U	N/A	N/A	D	E	1	23	0	634	1819:1742	339+228	111.7 : 111.7%
3/1+3/2	A441 Birmingham Rd (S) Ahead Right	U+O	N/A	N/A	B	C	1	87	13	1363	1641:1800	1069+157	111.1 : 111.1%
4/1	S Exit	U	N/A	N/A	-		-	-	-	773	Inf	Inf	0.0%
4/2	S Exit	U	N/A	N/A	-		-	-	-	525	Inf	Inf	0.0%
5/1	N Exit	U	N/A	N/A	-		-	-	-	1567	Inf	Inf	0.0%
6/1	E Exit	U	N/A	N/A	-		-	-	-	307	Inf	Inf	0.0%

Full Input Data And Results

Item	Arriving (pcu)	Leaving (pcu)	Turners In Gaps (pcu)	Turners When Unopposed (pcu)	Turners In Intergreen (pcu)	Uniform Delay (pcuHr)	Rand + Oversat Delay (pcuHr)	Storage Area Uniform Delay (pcuHr)	Total Delay (pcuHr)	Av. Delay Per PCU (s/pcu)	Max. Back of Uniform Queue (pcu)	Rand + Oversat Queue (pcu)	Mean Max Queue (pcu)
Network: A441 / Dagnell End Road	-	-	3	150	5	33.4	123.8	1.3	158.5	-	-	-	-
A441 / Dagnell End Road	-	-	3	150	5	33.4	123.8	1.3	158.5	-	-	-	-
1/2+1/1	1175	1175	-	-	-	7.7	13.4	-	21.2 (4.7+16.5)	64.9 (63.0:65.5)	36.2	13.4	49.6
2/2+2/1	634	568	-	-	-	12.0	37.4	-	49.4 (29.6+19.8)	280.8 (281.2:280.1)	17.1	37.4	54.5
3/1+3/2	1363	1226	3	150	5	13.6	73.0	1.3	87.9 (75.4+12.5)	232.1 (228.5:256.6)	54.3	73.0	127.3
4/1	773	773	-	-	-	0.0	0.0	-	0.0	0.0	0.0	0.0	0.0
4/2	498	498	-	-	-	0.0	0.0	-	0.0	0.0	0.0	0.0	0.0
5/1	1408	1408	-	-	-	0.0	0.0	-	0.0	0.0	0.0	0.0	0.0
6/1	289	289	-	-	-	0.0	0.0	-	0.0	0.0	0.0	0.0	0.0
C1 PRC for Signalled Lanes (%): -24.1 Total Delay for Signalled Lanes (pcuHr): 158.51 Cycle Time (s): 123 PRC Over All Lanes (%): -24.1 Total Delay Over All Lanes(pcuHr): 158.51													

Full Input Data And Results

Scenario 11: '11' (FG3: '2030 AM Effective Base + Dev', Plan 3: 'Network Control Plan 3 (Peds)')

Stage Sequence Diagram

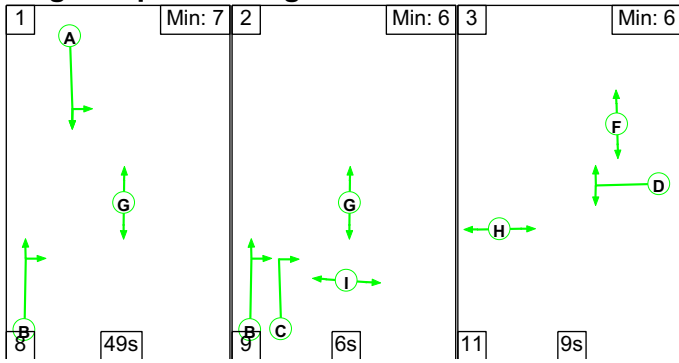

Stage Timings

Stage	1	2	3
Duration	49	6	9
Change Point	0	57	72

Signal Timings Diagram

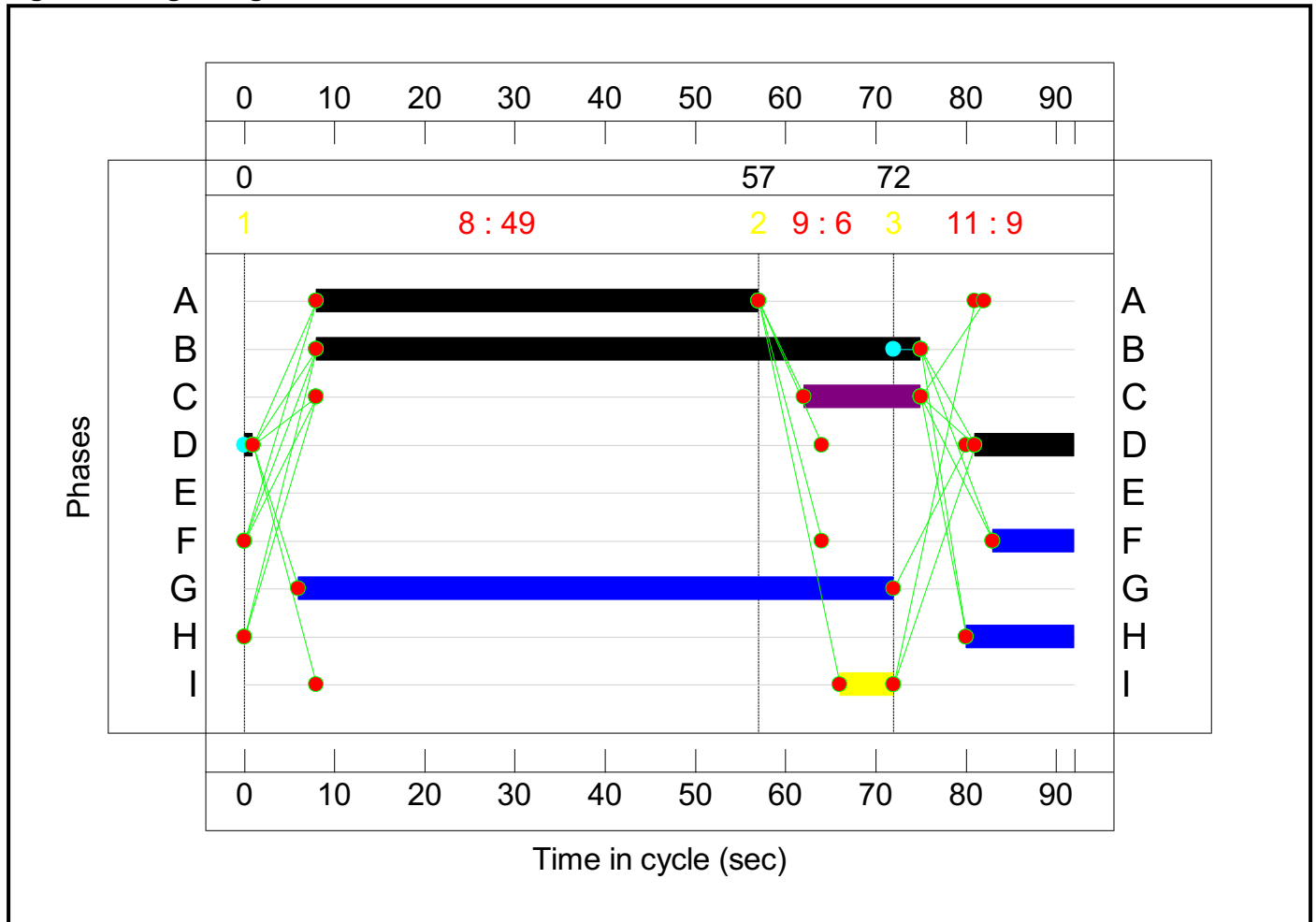

Network Layout Diagram

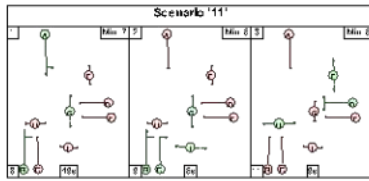

A441 / Dagnell End Road
 PRC: -24.7 %
 Total Traffic Delay: 150.8 pcuHr

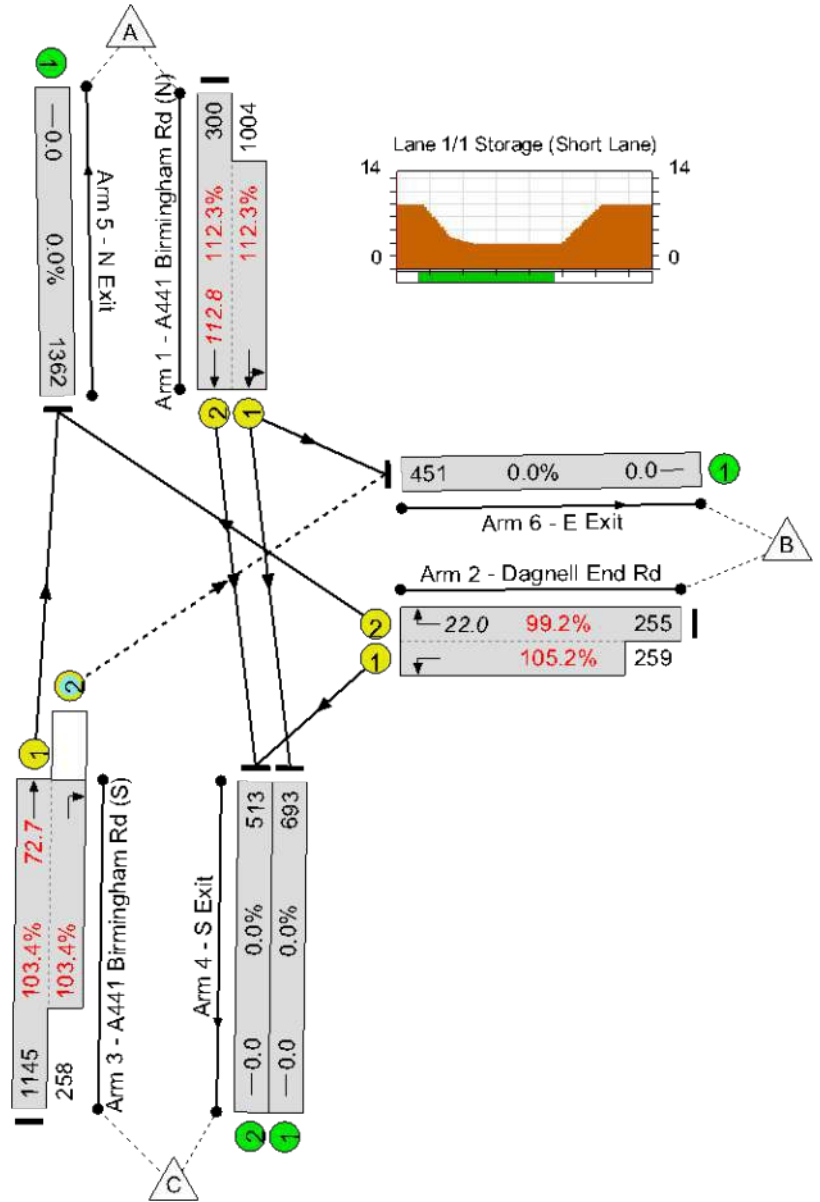
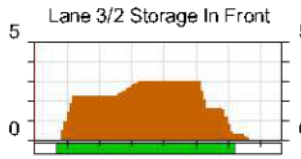
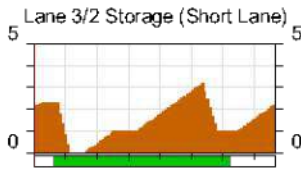
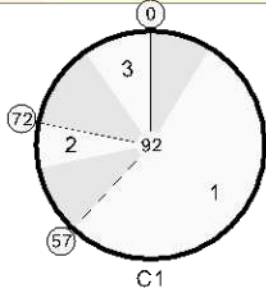

Full Input Data And Results

Network Results

Item	Lane Description	Lane Type	Controller Stream	Position In Filtered Route	Full Phase	Arrow Phase	Num Greens	Total Green (s)	Arrow Green (s)	Demand Flow (pcu)	Sat Flow (pcu/Hr)	Capacity (pcu)	Deg Sat (%)
Network: A441 / Dagnell End Road	-	-	N/A	-	-		-	-	-	-	-	-	112.3%
A441 / Dagnell End Road	-	-	N/A	-	-		-	-	-	-	-	-	112.3%
1/2+1/1	A441 Birmingham Rd (N) Ahead Left	U	N/A	N/A	A		1	49	-	1304	2105:1894	267+894	112.3 : 112.3%
2/2+2/1	Dagnell End Rd Left Right	U	N/A	N/A	D	E	1	12	0	514	1819:1742	257+246	99.2 : 105.2%
3/1+3/2	A441 Birmingham Rd (S) Ahead Right	U+O	N/A	N/A	B	C	1	67	13	1403	1726:1679	1107+249	103.4 : 103.4%
4/1	S Exit	U	N/A	N/A	-		-	-	-	778	Inf	Inf	0.0%
4/2	S Exit	U	N/A	N/A	-		-	-	-	559	Inf	Inf	0.0%
5/1	N Exit	U	N/A	N/A	-		-	-	-	1400	Inf	Inf	0.0%
6/1	E Exit	U	N/A	N/A	-		-	-	-	484	Inf	Inf	0.0%

Full Input Data And Results

Item	Arriving (pcu)	Leaving (pcu)	Turners In Gaps (pcu)	Turners When Unopposed (pcu)	Turners In Intergreen (pcu)	Uniform Delay (pcuHr)	Rand + Oversat Delay (pcuHr)	Storage Area Uniform Delay (pcuHr)	Total Delay (pcuHr)	Av. Delay Per PCU (s/pcu)	Max. Back of Uniform Queue (pcu)	Rand + Oversat Queue (pcu)	Mean Max Queue (pcu)
Network: A441 / Dagnell End Road	-	-	0	239	10	24.9	124.5	1.5	150.8	-	-	-	-
A441 / Dagnell End Road	-	-	0	239	10	24.9	124.5	1.5	150.8	-	-	-	-
1/2+1/1	1304	1161	-	-	-	12.8	75.6	-	88.4 (20.1+68.2)	243.9 (241.4:244.7)	37.2	75.6	112.8
2/2+2/1	514	501	-	-	-	6.0	15.4	-	21.3 (7.2+14.1)	149.5 (102.1:196.2)	6.7	15.4	22.0
3/1+3/2	1403	1357	0	239	10	6.1	33.6	1.5	41.1 (32.2+8.9)	105.5 (101.3:124.2)	39.1	33.6	72.7
4/1	693	693	-	-	-	0.0	0.0	-	0.0	0.0	0.0	0.0	0.0
4/2	513	513	-	-	-	0.0	0.0	-	0.0	0.0	0.0	0.0	0.0
5/1	1362	1362	-	-	-	0.0	0.0	-	0.0	0.0	0.0	0.0	0.0
6/1	451	451	-	-	-	0.0	0.0	-	0.0	0.0	0.0	0.0	0.0
C1 PRC for Signalled Lanes (%): -24.7 Total Delay for Signalled Lanes (pcuHr): 150.83 Cycle Time (s): 92 PRC Over All Lanes (%): -24.7 Total Delay Over All Lanes(pcuHr): 150.83													

Full Input Data And Results

Scenario 12: '12' (FG4: '2030 PM Effective Base + Dev', Plan 3: 'Network Control Plan 3 (Peds)')

Stage Sequence Diagram

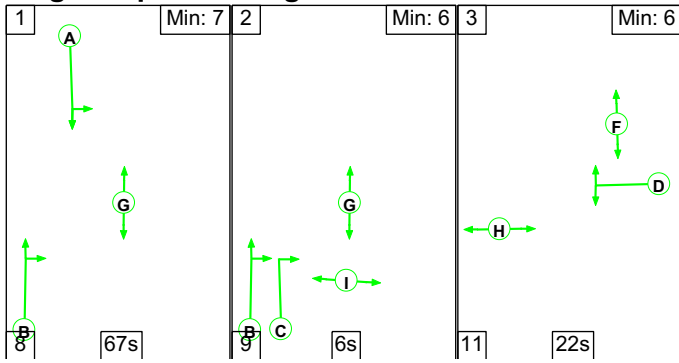

Stage Timings

Stage	1	2	3
Duration	67	6	22
Change Point	0	75	90

Signal Timings Diagram

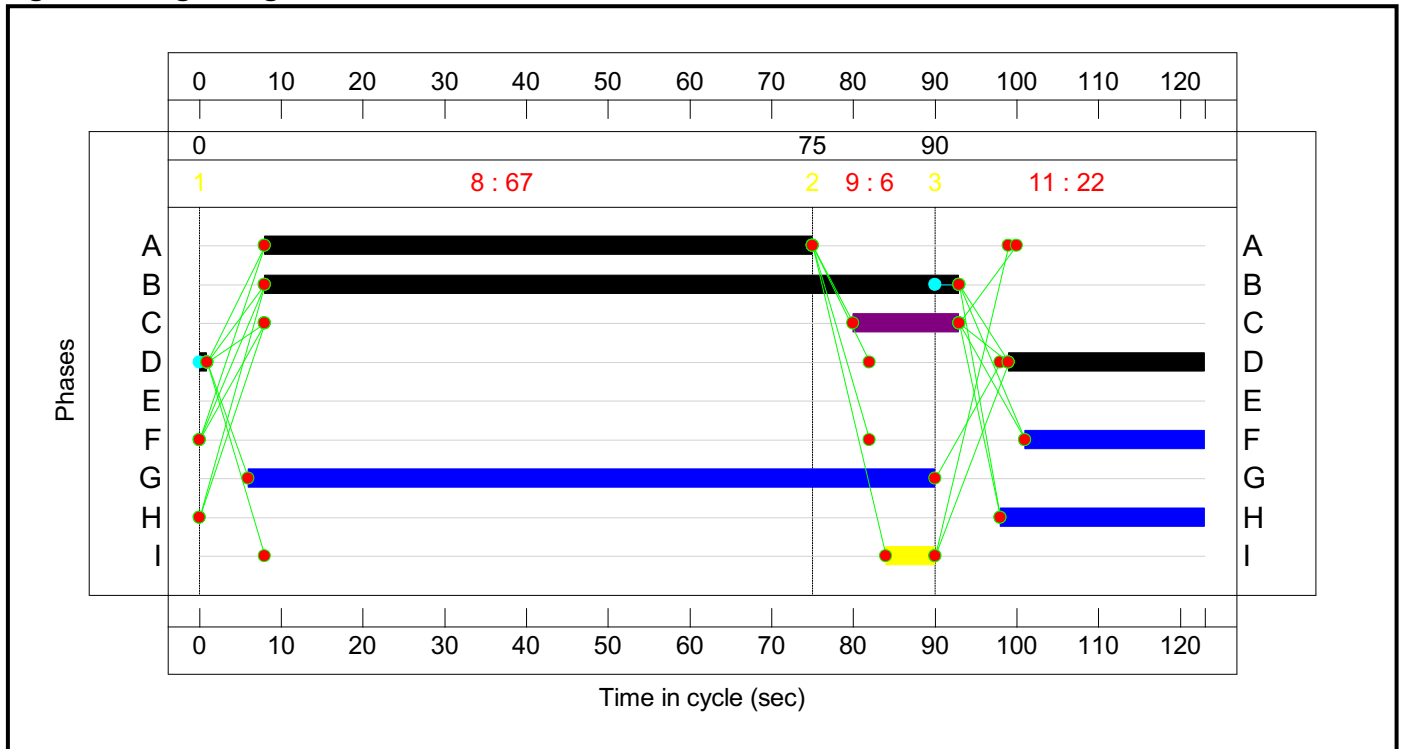

Network Layout Diagram

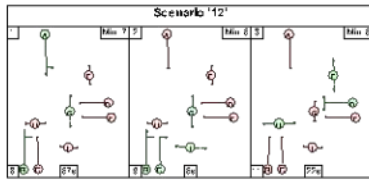

A441 / Dagnell End Road
 PRC: -29.1 %
 Total Traffic Delay: 237.7 pcuHr

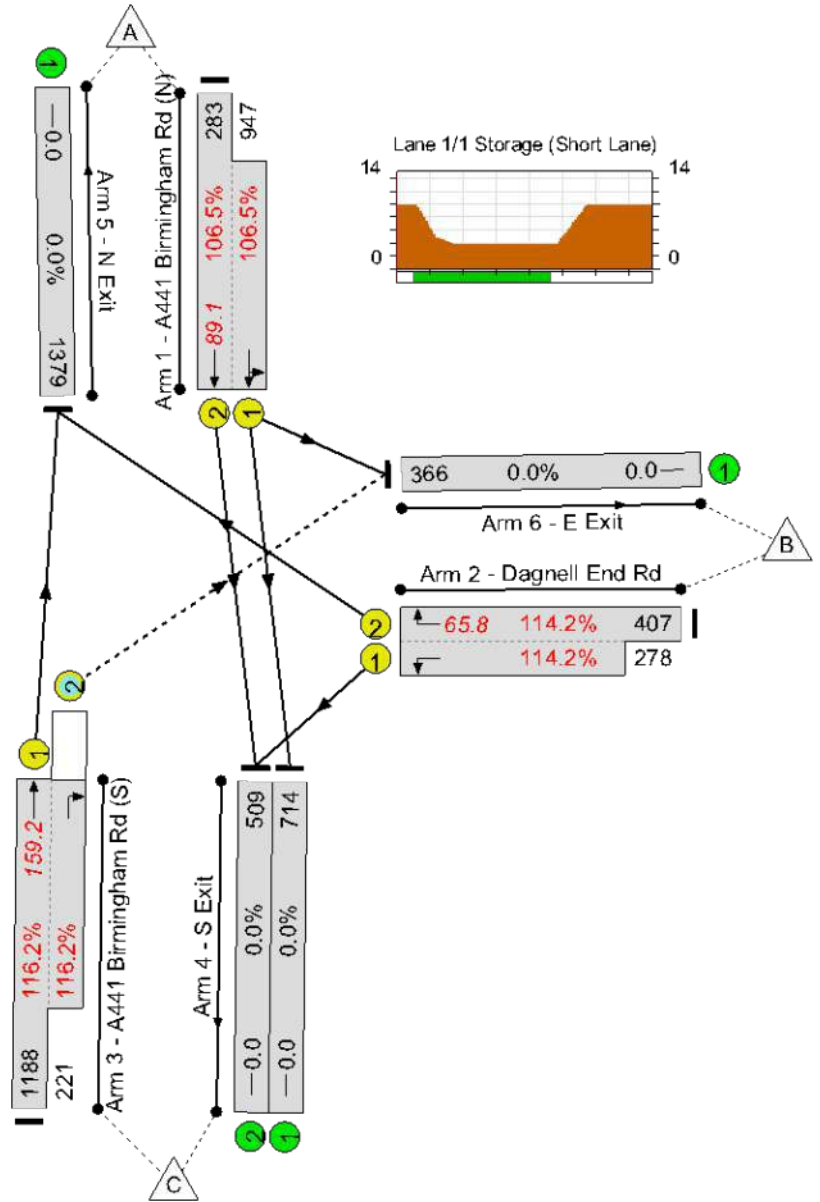
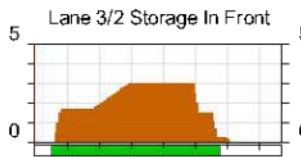
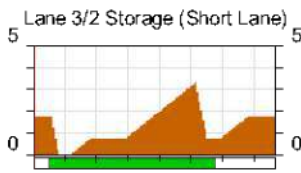
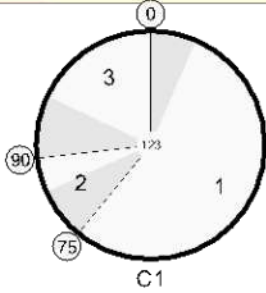

Full Input Data And Results

Network Results

Item	Lane Description	Lane Type	Controller Stream	Position In Filtered Route	Full Phase	Arrow Phase	Num Greens	Total Green (s)	Arrow Green (s)	Demand Flow (pcu)	Sat Flow (pcu/Hr)	Capacity (pcu)	Deg Sat (%)
Network: A441 / Dagnell End Road	-	-	N/A	-	-		-	-	-	-	-	-	116.2%
A441 / Dagnell End Road	-	-	N/A	-	-		-	-	-	-	-	-	116.2%
1/2+1/1	A441 Birmingham Rd (N) Ahead Left	U	N/A	N/A	A		1	67	-	1230	2105:1902	266+889	106.5 : 106.5%
2/2+2/1	Dagnell End Rd Left Right	U	N/A	N/A	D	E	1	25	0	685	1819:1742	356+243	114.2 : 114.2%
3/1+3/2	A441 Birmingham Rd (S) Ahead Right	U+O	N/A	N/A	B	C	1	85	13	1409	1641:1800	1023+190	116.2 : 116.2%
4/1	S Exit	U	N/A	N/A	-		-	-	-	760	Inf	Inf	0.0%
4/2	S Exit	U	N/A	N/A	-		-	-	-	561	Inf	Inf	0.0%
5/1	N Exit	U	N/A	N/A	-		-	-	-	1595	Inf	Inf	0.0%
6/1	E Exit	U	N/A	N/A	-		-	-	-	408	Inf	Inf	0.0%

Full Input Data And Results

Item	Arriving (pcu)	Leaving (pcu)	Turners In Gaps (pcu)	Turners When Unopposed (pcu)	Turners In Intergreen (pcu)	Uniform Delay (pcuHr)	Rand + Oversat Delay (pcuHr)	Storage Area Uniform Delay (pcuHr)	Total Delay (pcuHr)	Av. Delay Per PCU (s/pcu)	Max. Back of Uniform Queue (pcu)	Rand + Oversat Queue (pcu)	Mean Max Queue (pcu)
Network: A441 / Dagnell End Road	-	-	0	184	6	44.2	192.1	1.4	237.7	-	-	-	-
A441 / Dagnell End Road	-	-	0	184	6	44.2	192.1	1.4	237.7	-	-	-	-
1/2+1/1	1230	1155	-	-	-	12.8	44.4	-	57.2 (13.0+44.2)	167.5 (165.2:168.2)	44.7	44.4	89.1
2/2+2/1	685	600	-	-	-	13.7	46.2	-	59.9 (35.7+24.3)	315.0 (315.4:314.4)	19.6	46.2	65.8
3/1+3/2	1409	1213	0	184	6	17.6	101.5	1.4	120.5 (100.2+20.3)	307.8 (303.6:330.8)	57.7	101.5	159.2
4/1	714	714	-	-	-	0.0	0.0	-	0.0	0.0	0.0	0.0	0.0
4/2	509	509	-	-	-	0.0	0.0	-	0.0	0.0	0.0	0.0	0.0
5/1	1379	1379	-	-	-	0.0	0.0	-	0.0	0.0	0.0	0.0	0.0
6/1	366	366	-	-	-	0.0	0.0	-	0.0	0.0	0.0	0.0	0.0
C1 PRC for Signalled Lanes (%): -29.1 Total Delay for Signalled Lanes (pcuHr): 237.65 Cycle Time (s): 123 PRC Over All Lanes (%): -29.1 Total Delay Over All Lanes(pcuHr): 237.65													

APPENDIX H

Dagnell End Mitigation – Stage Sequence Figures

Figure 6.1: Stage Sequence 1 – Pedestrian Crossing Not Called

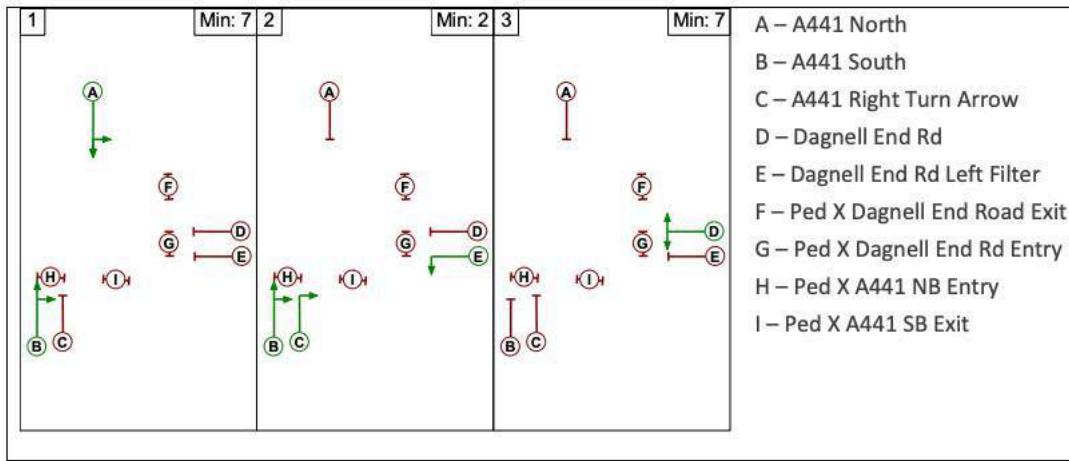

Figure 6.2: Stage Sequence 2 – Pedestrian Crossing Not Called, No Filter Arrow

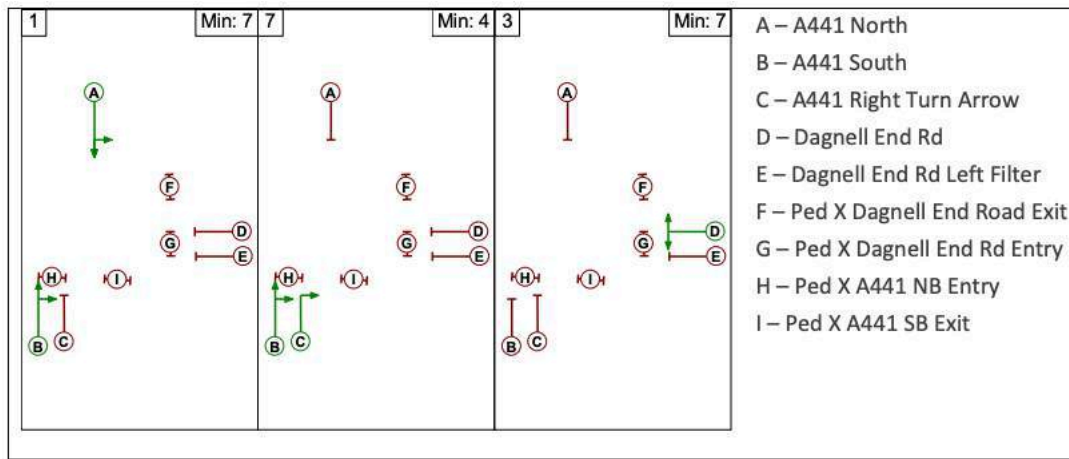
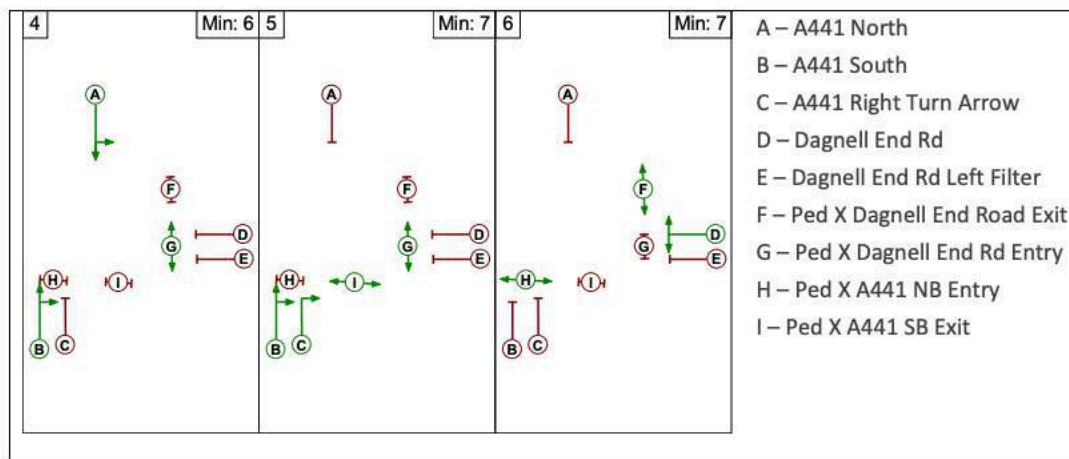

Figure 6.3: Stage Sequence 1 – Pedestrian Crossing Called Every Cycle (Sensitivity Test)





transport planning

keep up with mode:



Birmingham

☎ 0121 794 8390

London

☎ 020 7293 0217

Manchester

☎ 0161 464 9495

Reading

☎ 0118 206 2945

✉ info@modetransport.co.uk 📍 modetransport.co.uk 🐦 [@mode_transport](https://twitter.com/mode_transport)